



S

M

A

R

C A R T

T



*Over the years, AFC has maintained its position as a leading designer and manufacturer of a diverse line of high-quality furniture, built to enhance performance, comfort and satisfaction in the fast paced modern workplace.*

*While offering excellent value and customer service, we set the pace for the industry. AFC's broad selection of workstations, specialized carts, racking systems and accessories are built with the highest quality durable materials. Our modular designs offer flexibility and customization to accommodate diverse users. All AFC products are shipped from our factory, fully assembled for your convenience.*

*Our expert staff of customer service representatives is available to assist you with all aspects of room layout and design, thereby helping you make the right choice. The results are workplace solutions that meet or exceed our customer's expectations.*

*Contact us today to find out more about what AFC can do for your business.*

# Table of Contents

**Specifications** ..... 2

**Work Surface Shapes** ..... 4

**Top Options** ..... 6

**Bottom Options** ..... 7

**Color Chart** ..... 8

**SmartCart Modularities** ..... 9

**“L” & Corner Configurations** ..... 16

**Room Layouts** ..... 20

## Specifications

The versatility offered by AFC's **SmartCart** makes it a wonderful addition to any business environment. With virtually limitless configurations and customization capabilities you will find that this cart fits your needs perfectly. All **SmartCarts** are built exclusively from reinforced steel with pressurized scratch resistant laminate surfaces, making them extremely strong and durable.

Choose from any combination of features and let us create the **SmartCart** that is right for you. No matter what your workplace requirements are, you will find that our ergonomically designed **SmartCarts** will enhance productivity and give you a lifetime of dependable service that you will enjoy.



### Features:

- 2" or 4" casters (two of them locking)
- Cold rolled 11 Gauge steel frame with Epoxy powder coated finish
- Particle board core top with a high pressure laminate finish of your choice edged with T-molding; Phenolic plastic (chemical resistant) work surfaces also available
- Work surface and shelves are height adjustable in 1" increments
- Customized Ergonomic and Standard work surfaces available
- Split bottom shelf on either one or both sides providing leg space or full-length bottom shelf to accommodate CPU or other computer related products
- Multiple colors available! (See page 8)

### Standard Sizes:

#### Width:

18", 24", 30", 36", 48",  
60", 72", 84", 96"

#### Depth:

24", 30", 36"

#### Height of Work Surface:

30" - 36" seated position  
42" standing position



2" Twin Caster with brake



4" Caster with brake



Glide

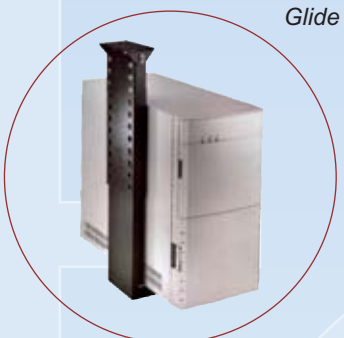

CPU Holder



Rack Mount

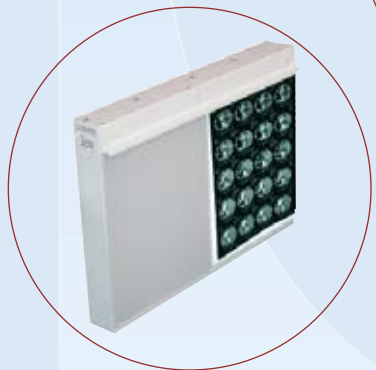

Illuminator



Sliding Door Cabinet



Film Box

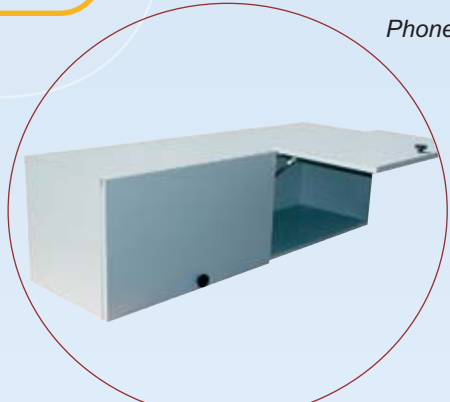

Flipper Cabinet

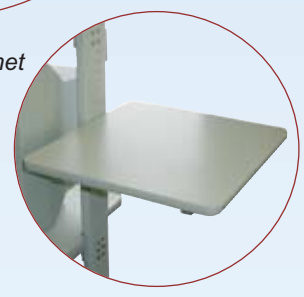

Side Extension

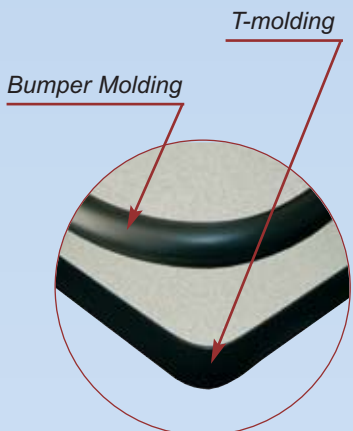

Bumper Molding

T-molding



Keyboard Arm & Tray



Monitor Arm

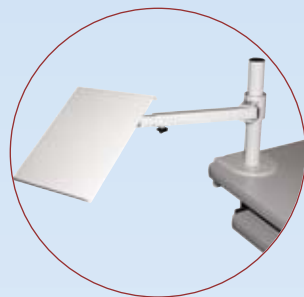

Phone Arm

- Options:**
- Glides instead of casters
  - Work surface and shelves edged with Bumper Molding
  - Top shelves & Side Extensions
  - Keyboard Arms & Trays
  - Monitor Arms
  - Phone Arms
  - CPU Holders
  - Flipper cabinets
  - Illuminators
  - Rack Mounts
  - Film Boxes



# Work Surface Shapes

Choose one of our standard surface shapes or call us to customize your work surface!



Standard  
for all widths

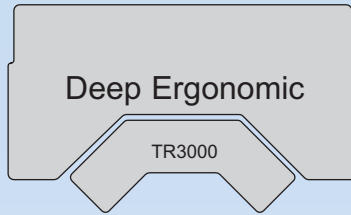

Deep Ergonomic  
for 48" wide tables and up



Soft Ergonomic  
for all widths

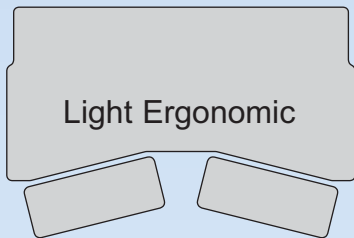

Light Ergonomic  
for 60" wide tables and up

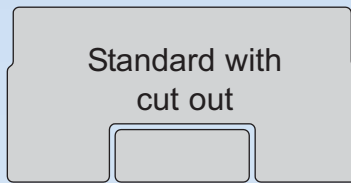

Standard with cut out  
for 36" wide tables and up

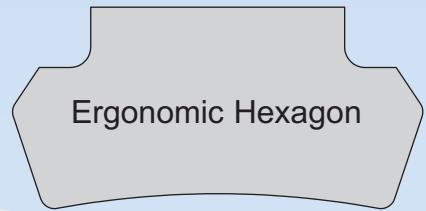

Ergonomic Hexagon  
for 48" wide tables and up

See page 8 for color options!

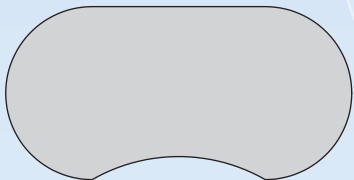

for 48" wide tables and up

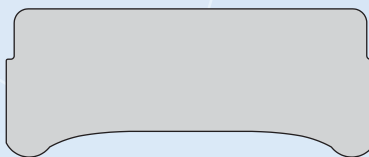

for 48" wide tables and up

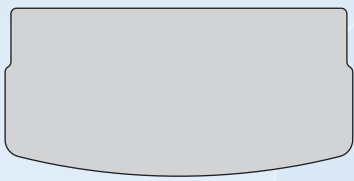

for 36" wide tables and up



for 48" wide tables and up



18" W x 18" D x 39" H



72" W x 24" D x 30" H



72" W x 30" D x 30" H



72" W x 30" D x 30" H

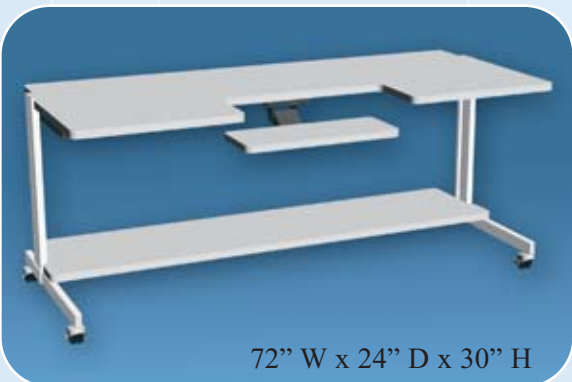

72" W x 24" D x 30" H



24" W x 24" D x 42" H

AFC SmartCart Deluxe with concealed mounting holes add aesthetic value to the station.



24" W x 30" D x 30" H

# Top Options



a



b



c



d

- Top Shelf
- Side Extension
- Rack Mount
- Film Box
- Illuminator
- Flipper Cabinet



e



f



g



h



# Bottom Options



- Full-length Shelf
- Split Bottom Shelf
- Drawer
- Side Extension
- Film Box
- Storage Cabinet
- Rack Mount



# Color Chart

## Laminate:



Black

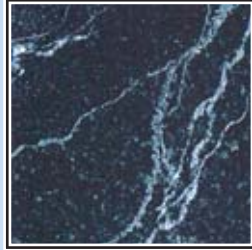

Classic Black



Speckled Gray

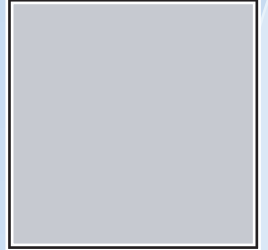

Gray



Mahogany



Wild Cherry



Natural Pear

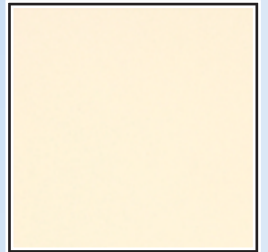

Putty

## Phenolic Plastic:

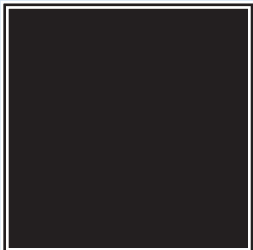

Black



For any other color please call us at

1-800-663-3412

## Molding:



Black



Gray

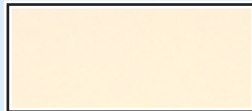

Putty

## Frame:



Black

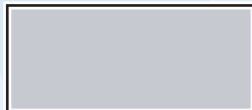

Gray

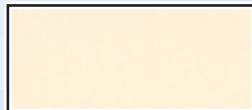

Putty

# SmartCart Modularities

Our ergonomically designed **SmartCarts** are the perfect solution for any workspace! The following pages illustrate just a few of the many possibilities these carts can offer your business.

<p><b>a</b></p>  <p>Standard work surface and bottom shelf</p>	<p><b>b</b></p>  <p>Standard work surface and two bottom shelves</p>	<p><b>c</b></p>  <p>Standard work surface, top shelf, and bottom shelf</p>
<p><b>d</b></p>  <p>Standard work surface, top shelf, and bottom shelf</p>	<p><b>e</b></p>  <p>Standard work surface and flipper cabinet</p>	<p><b>f</b></p>  <p>Standard work surface, middle shelf and flipper cabinet</p>
<p><b>g</b></p>  <p>Standard work surface, top shelf, and middle shelf</p>	<p><b>h</b></p>  <p>Standard work surface, top shelf, middle shelf, and bottom shelf</p>	<p><b>i</b></p>  <p>Standard work surface, top shelf, and storage cabinet</p>
<p><b>j</b></p>  <p>Standard work surface and bottom shelf</p>	<p><b>k</b></p>  <p>Standard work surface, top shelf, and deep bottom shelf</p>	<p><b>l</b></p>  <p>Standard work surface, top shelf, and two bottom shelves</p>

# SmartCart Modularities

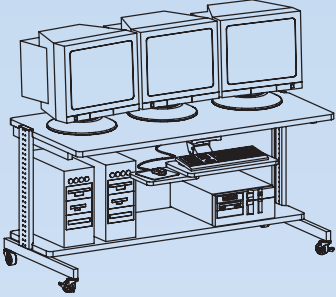
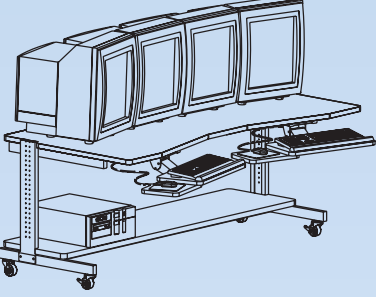
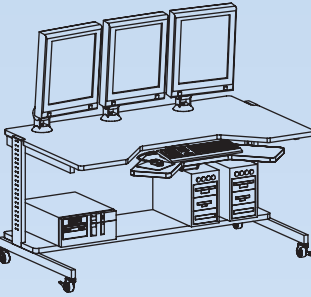
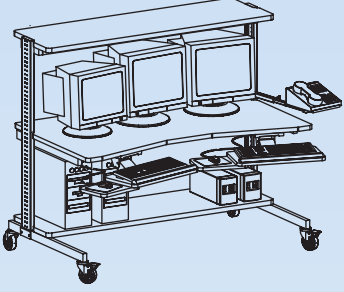
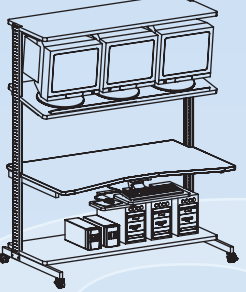
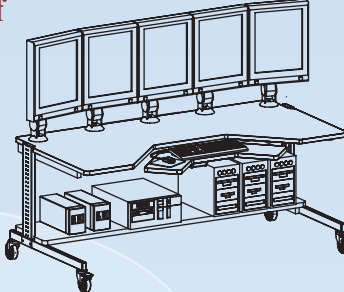
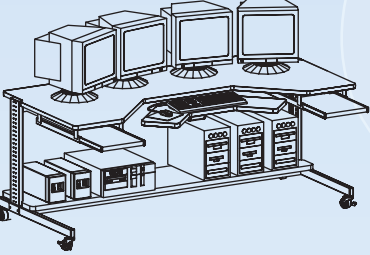
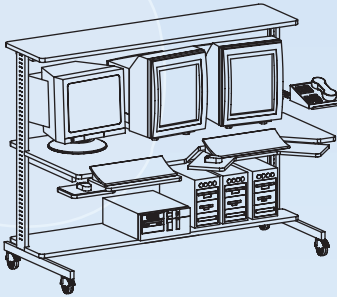
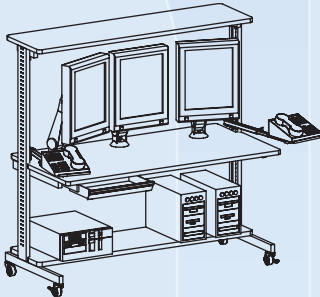
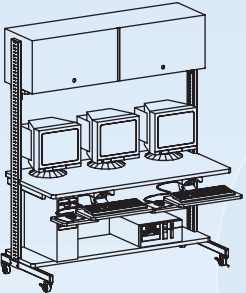
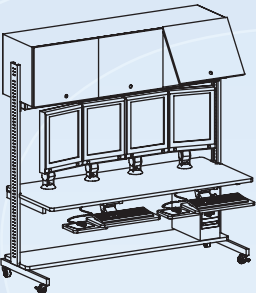
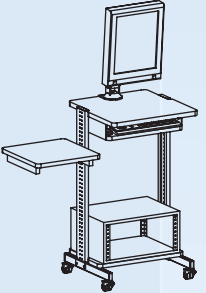
<p><b>a</b></p>  <p>Standard work surface</p>	<p><b>b</b></p>  <p>Light ergonomic work surface</p>	<p><b>c</b></p>  <p>Deep ergonomic work surface</p>
<p><b>d</b></p>  <p>Light ergonomic work surface, top shelf and phone arm</p>	<p><b>e</b></p>  <p>Light ergonomic work surface, top shelf and tilted middle shelf</p>	<p><b>f</b></p>  <p>Deep ergonomic work surface</p>
<p><b>g</b></p>  <p>Deep ergonomic work surface and retractable writing surfaces</p>	<p><b>h</b></p>  <p>Deep ergonomic combined work surface, top shelf, and phone arm</p>	<p><b>i</b></p>  <p>Standard work surface, top shelf, two phone arms, &amp; pencil drawer</p>
<p><b>j</b></p>  <p>Standard work surface and flipper cabinet</p>	<p><b>k</b></p>  <p>Standard work surface and flipper cabinet</p>	<p><b>l</b></p>  <p>Standard work surface, rack mount and side extension</p>

Configure your own SmartCart with the simple click of a mouse!  
 Go to our **Interactive SmartCart Builder** at  
[www.afcindustries.com/configurator](http://www.afcindustries.com/configurator)



◀ 60" W x 36" D x 58" H

84" W x 30" D x 30" H



◀ 72" W x 36" D x 72" H



# SmartCart Modularities

The **SmartCart**'s flexibility allows you to change the configuration of the cart as well as the design and layout of the work environment. The **SmartCarts**, like all of our products will turn your workspace vision into a reality.

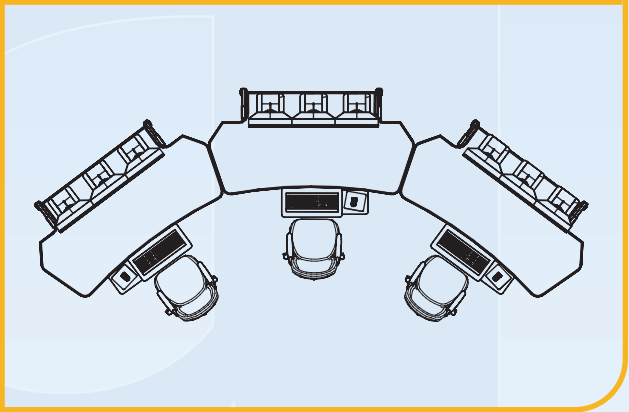
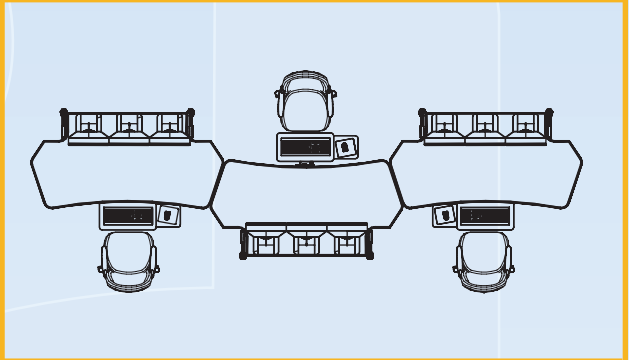
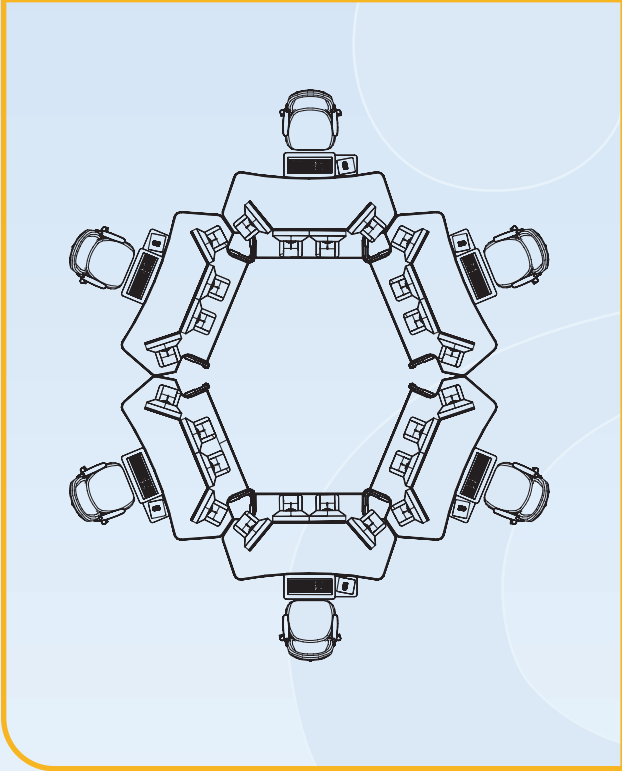
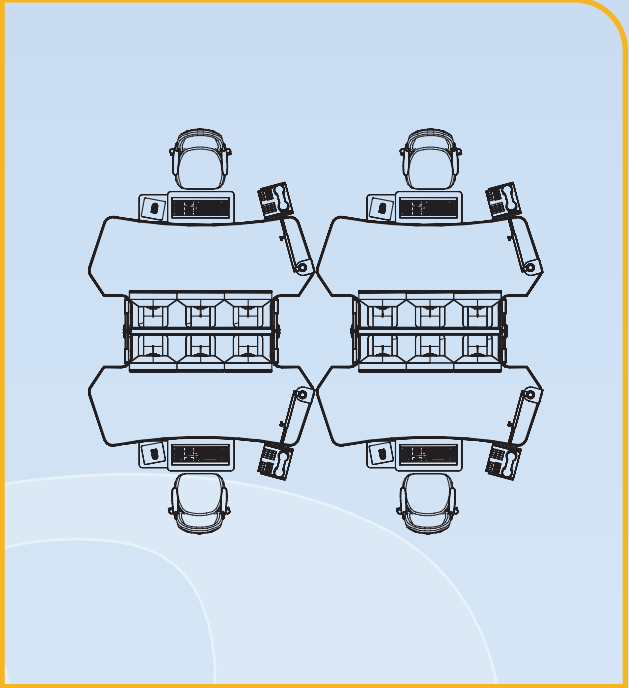
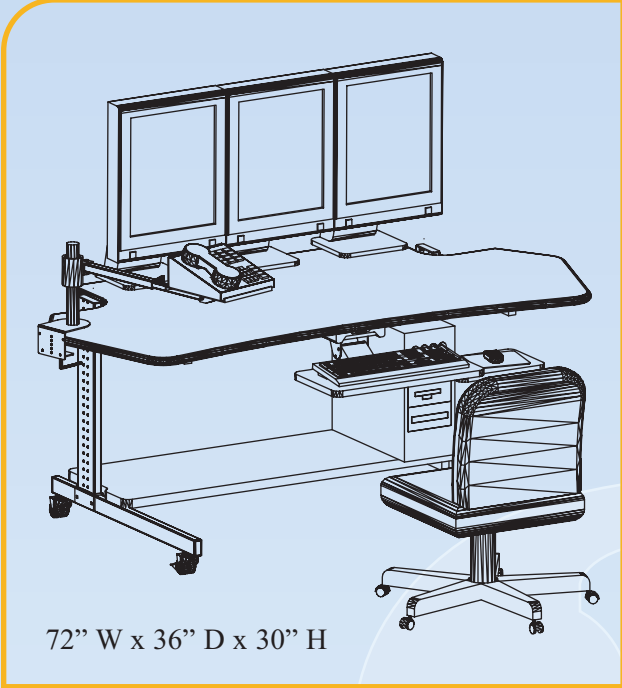



# SmartCart Modularities

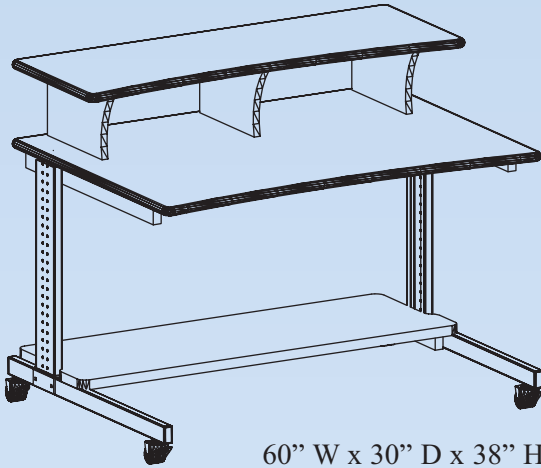

60" W x 30" D x 38" H

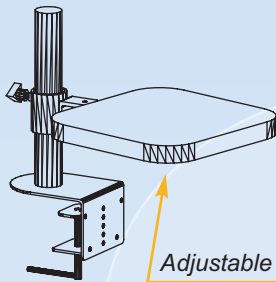
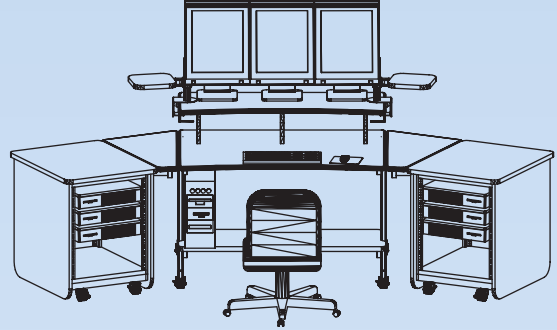

Adjustable Mini Side Extension

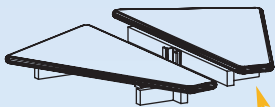

Left/Right Side 25°/35°/45° Connectors

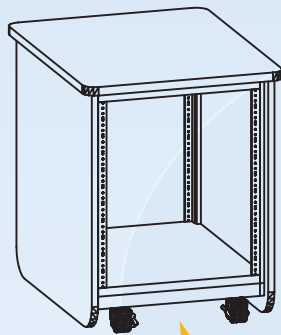
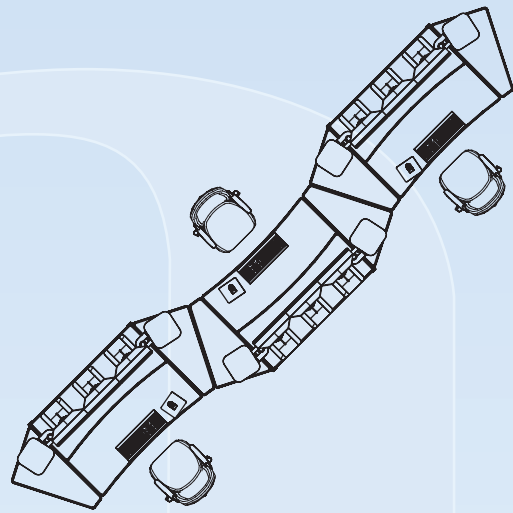

Rack Mobile

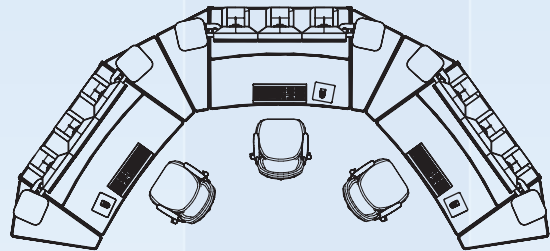

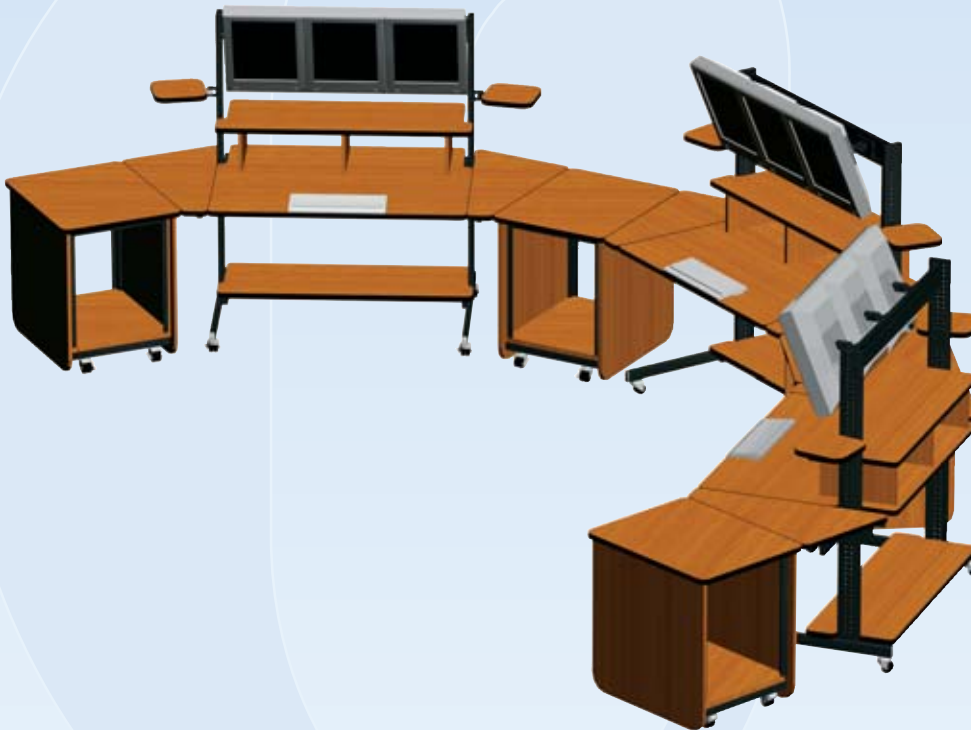

# "L" & Corner Configurations

Select the shape & size best suited to your application or call us for customization!

## Corner Configurations

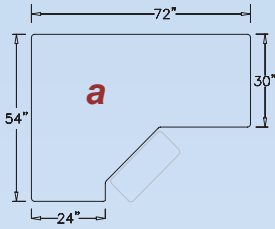

right hand return

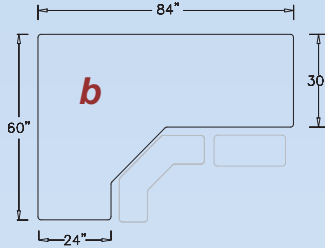

right hand return

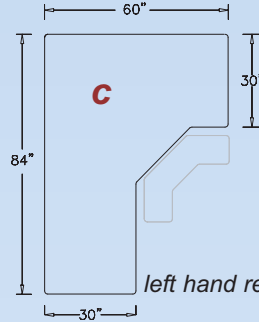

left hand return

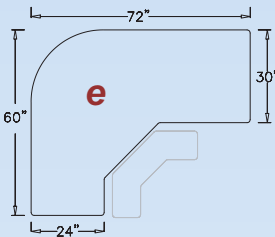
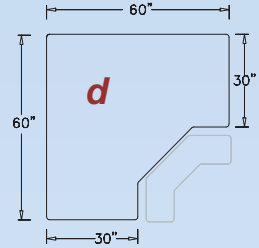

right hand return

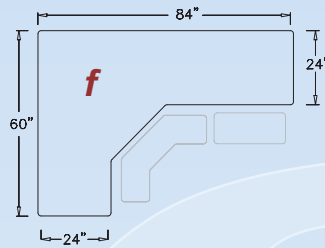

right hand return

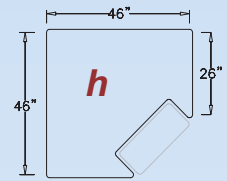
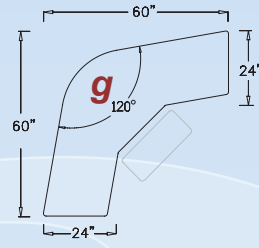

## "L" Configurations

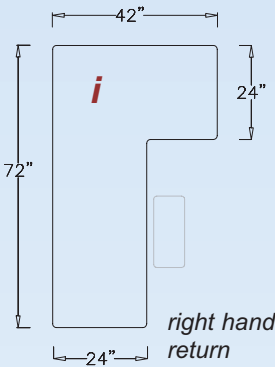

right hand return

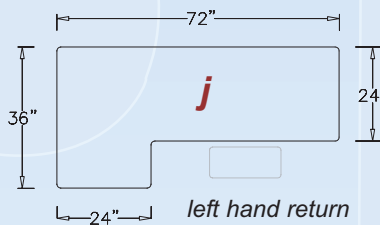

left hand return

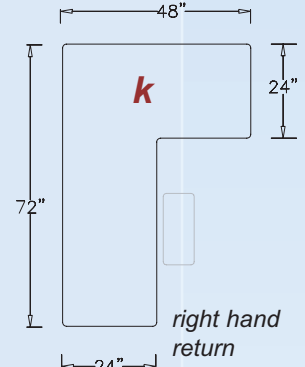

right hand return

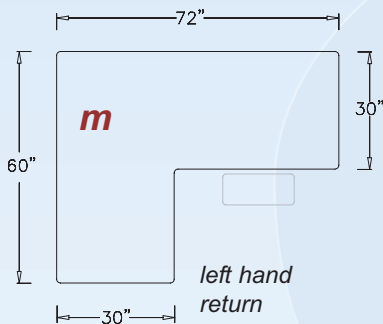

left hand return

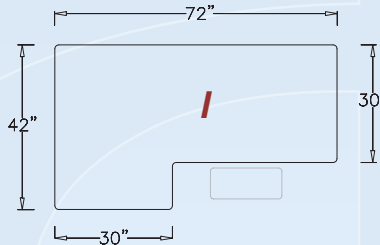

l

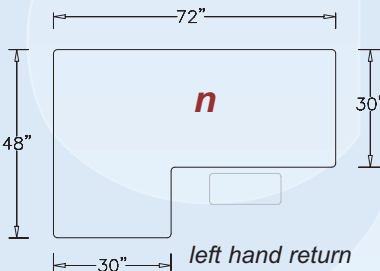

left hand return

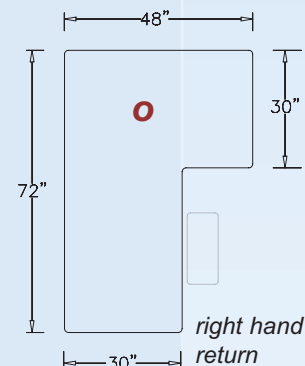

right hand return



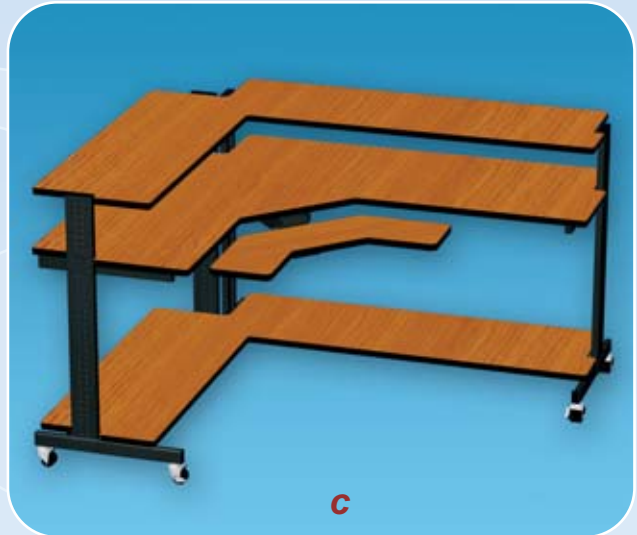
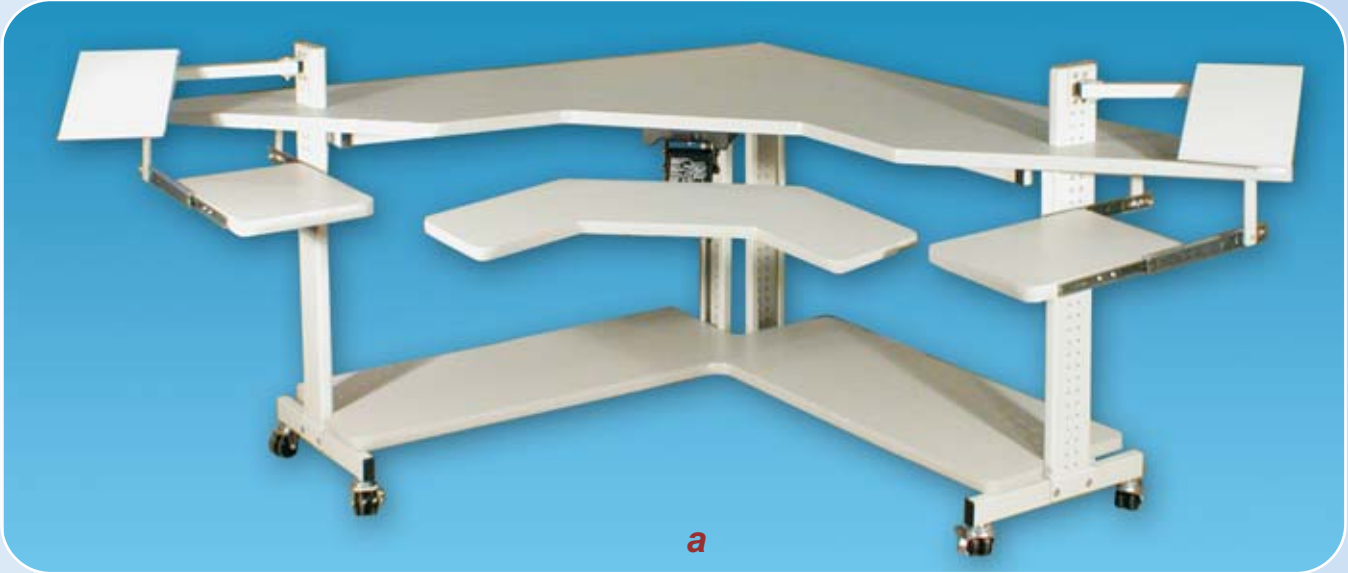

# “L” & Corner Configurations

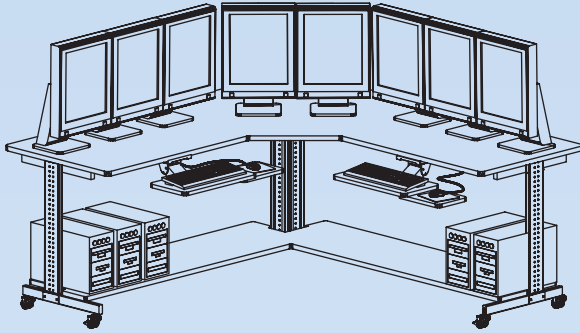

Our “L” & Corner configurations allow you to organize a multi-task environment with a design suited to your floor plan, optimizing work flow and productivity.

**Complete your workstation plan with soundproof partitions!**

Our partitions provide privacy and act as sound and light barriers. They can include a plexi-glass panel across the top so operators can see outside of their “cubicle”.

AFC Partitions can be configured to suit your application.

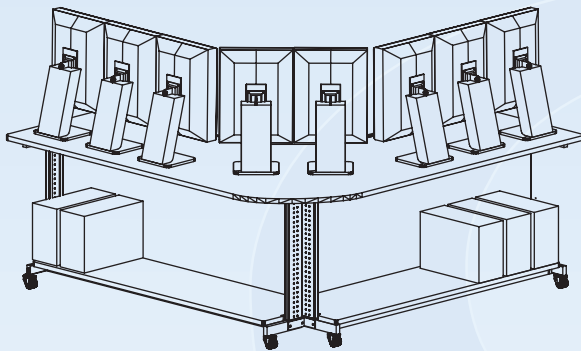

84”W x 84” W x 30”D x 30” D x 30” H

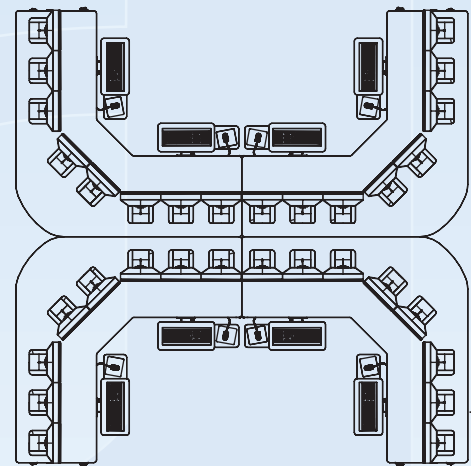
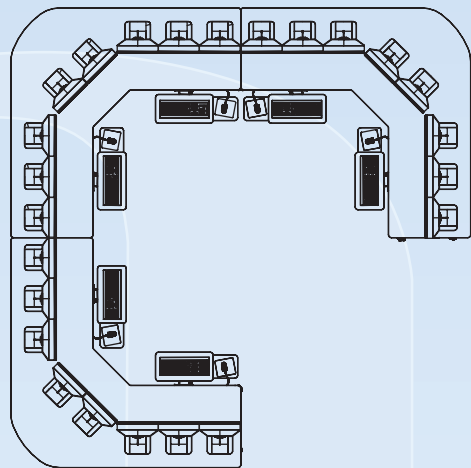
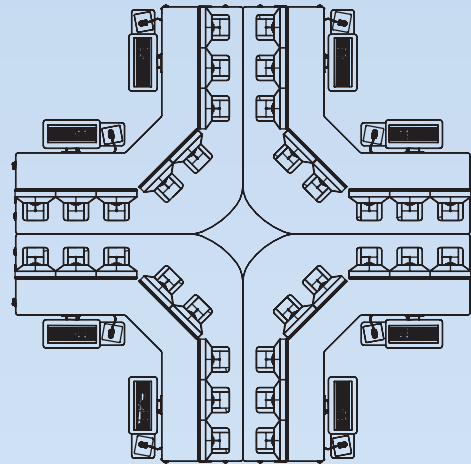

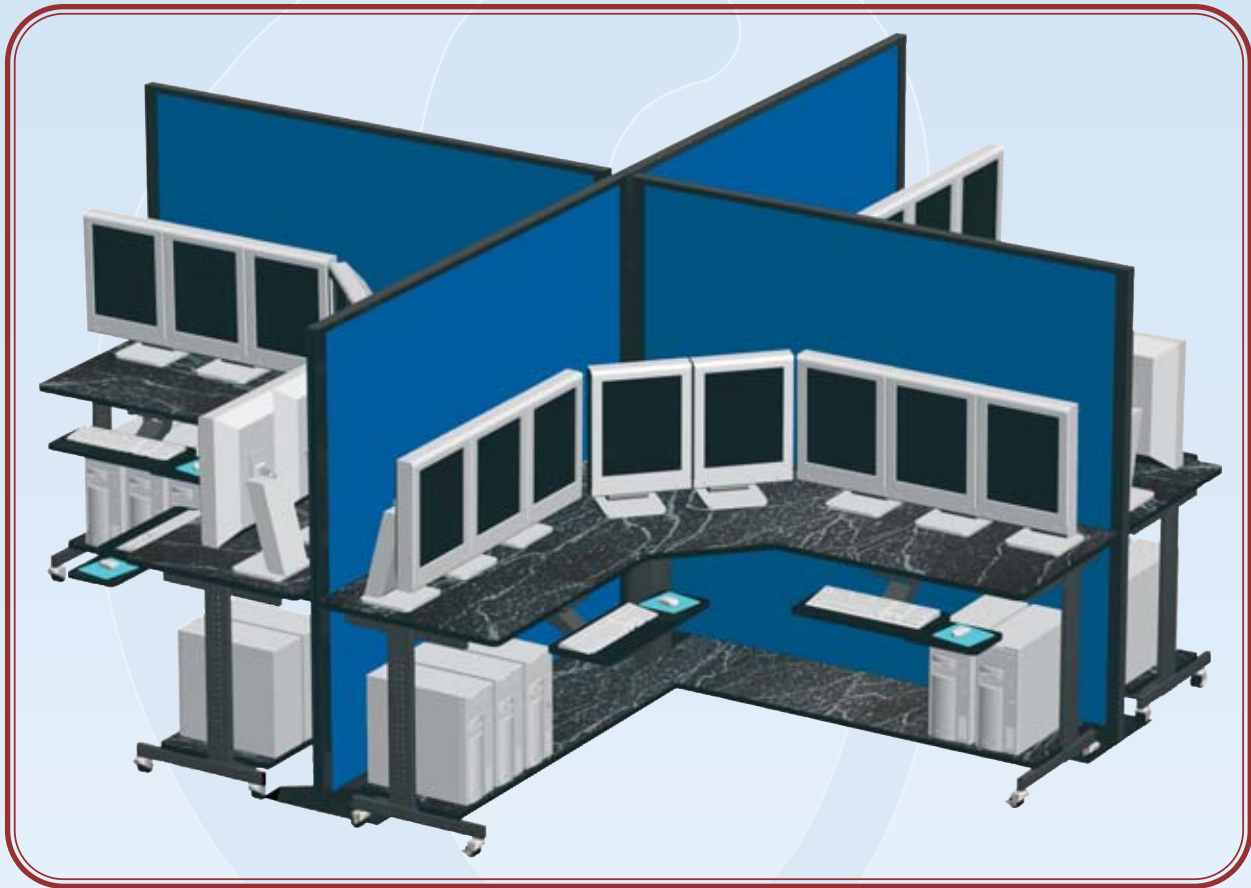

# Room Layouts

**Need help designing your workspace?**

- AFC engineers are available to help you design your work area
- We are available for on-site evaluation of your facility
- We can provide you with 3 dimensional drawings to allow you to evaluate designs before you place your order

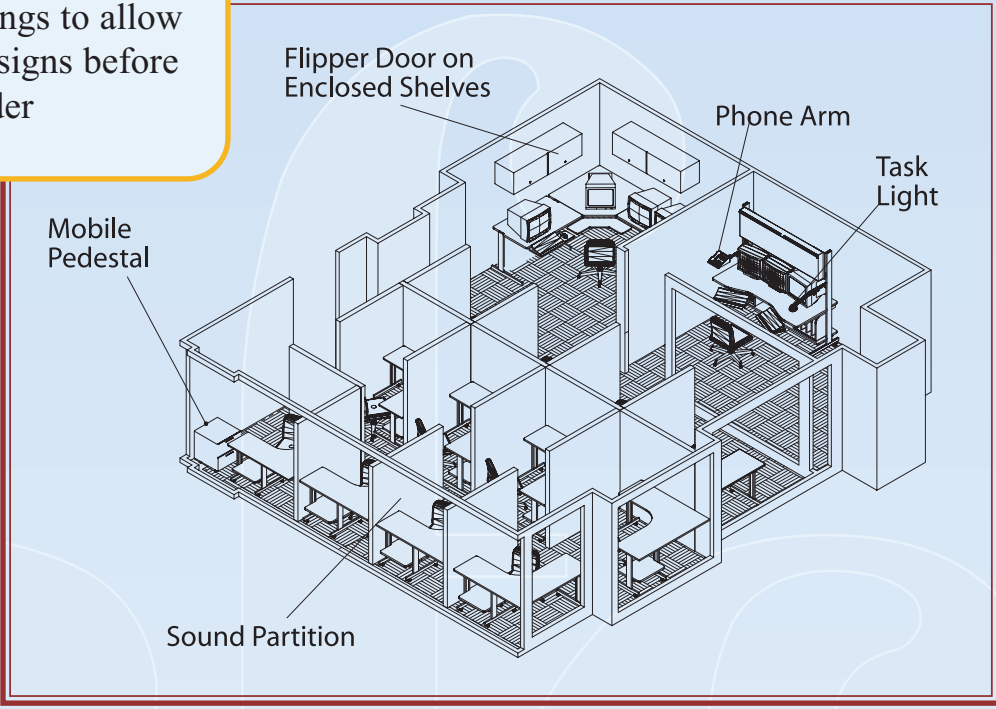
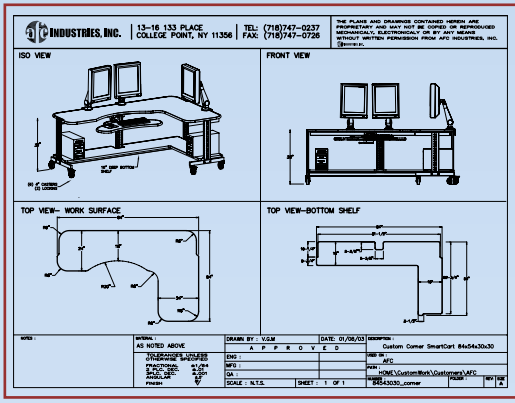

**Regardless of your space requirements AFC SmartCarts offer a compatible fit!**

**We will customize your SmartCart to fit your room dimensions!**





1-800-663-3412



## Room Layouts

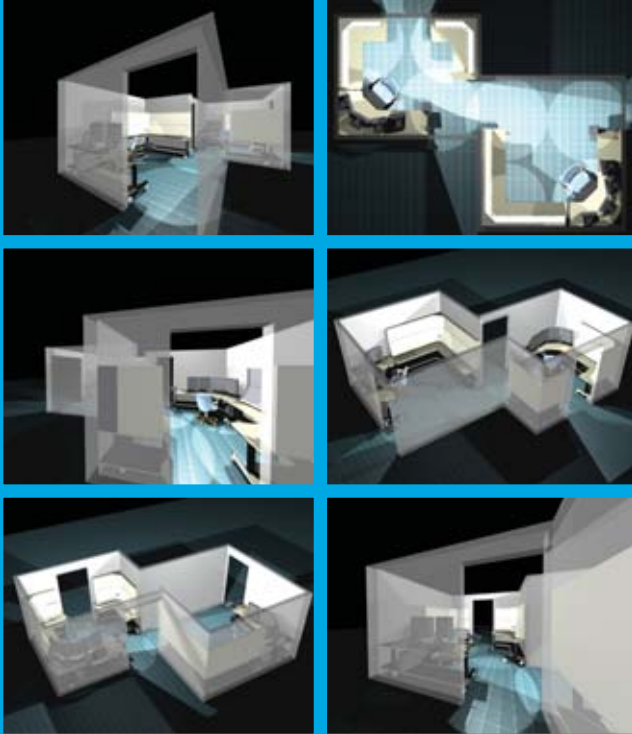

[www.afciindustries.com](http://www.afciindustries.com)

**Please Note:** Specifications in this catalog are subject to change without notice. Actual structure design may vary. The illustrations and pictures shown in this catalog are for presentation purposes only.



# AFC INDUSTRIES, INC.



[www.afcindustries.com](http://www.afcindustries.com)

We deliver all products fully assembled to ensure maximum strength and convenience

Tel: (718) 747-0237

Fax: (718) 747-0726

**1-800-663-3412**

[info@afcindustries.com](mailto:info@afcindustries.com)

**AFC INDUSTRIES, INC.**  
13-16 133<sup>rd</sup> Place  
College Point, NY 11356

Presorted Standard  
US POSTAGE  
**PAID**  
Flushing, NY  
PERMIT # 1427

**afc INDUSTRIES, INC.**