

RADIOLOGY



www.afcindustries.com

READING ROOM *furniture*

Contents

Ongoing research has proved that ergonomically designed work stations and environments are directly linked to worker productivity and comfort. In today's demanding healthcare environment, a well designed, efficient and pleasant work setting is vital to your productivity and success.

Since 1994, AFC Industries, Inc. has created and manufactured a diverse line of ergonomically designed workstations, point-of-care carts, wall mounts and i-Centers™. These height adjustable units guarantee the right height for standing desks as well as traditional sitting levels which can accommodate a diverse healthcare workforce to enhance performance, comfort and satisfaction in the fast-paced modern work arena.

Whether you require assistance in choosing the appropriate components to configure a product or a complete room redesign, our staff of engineers and ergonomic design experts is available to provide you with the solutions you need for your projects.

Whatever your needs, AFC Industries, will manufacture your solution! Remember too, that additional designs and models are available on our website at www.afcindustries.com.



INTERACTIVE WORKSTATIONS... 4



MOBILE DATA ACCESS 18



WALL MOUNT SOLUTIONS 24



ACCESSORIES 30

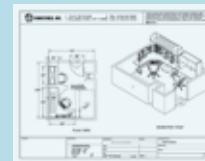

COMPLIMENTARY SERVICES 34



STANDARD COLORS 35

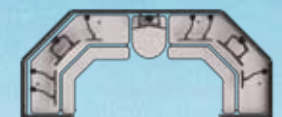

Interactive workstations. Flexible. Adjustable. Adapt to you!

Sit. Stand. Raise monitors. Lower monitors. Move them in. Move them out. These are the building blocks of an ergonomic workstation.

Different users. Different needs. AFC workstations. Electronically height-adjustable at the touch of a button. Independent adjustment of monitor height and focal length for optimal viewing. Digital readouts to preserve and easily return to your ideal settings for surface and monitor placement. Available with surface tilt. A host of valuable features—ambient LED backlighting to ease eye strain and improve reading quality; a variety of monitor platforms; mounting solutions for the growing interest in large monitors; acoustical privacy partition to improve concentration; pop-up data port and built-in USB hub to facilitate neat and tidy use of ancillary equipment. And more.

Our flexible workstations and carts come in a wide variety of sizes, shapes, multi-tiered designs, and color options that accommodate virtually any location and workplace need. They can be enhanced with cabinetry, shelving, computer storage, and retractable features.

AFC workstations. Helping you perform better.

Features and Benefits

- Electronic height adjustment of work surface
- Monitor arms with horizontal, vertical, and tilt adjustment
- Complete wall-to-wall installation services
- Cold-rolled 11-gauge steel frame with epoxy-powder-coated finish
- Particle-board core top with your choice of high-pressure laminate finish edged with bumper molding
- Multiple color available (for standard colors, see page 35)

Optional

- Electronic adjustment of monitor height and focal length
- Advanced warm/cool air environmental control system regulated at the workstation
- Pop-up data ports and a built-in USB hub embedded in the work surface
- Light and sound barrier partitions
- Partitions with removable lower metal panel for back CPU access and continuous cable management
- Mobile CPU enclosure

The Whitestone™

The **Whitestone™** workstation is AFC's radiology dream station, loaded with a full array of electronics, lighting, power and cable management that facilitate performance, comfort, and ease of use.

Electronic Adjustment:

- SURFACE HEIGHT
- SURFACE TILT
- MONITOR HEIGHT
- FOCAL LENGTH

Complete electronic adjustment capabilities are the foundation of this highly adaptable workstation — for surface height in sit-stand positions, surface tilt, and both vertical and horizontal adjustment of monitors. Digital readouts for all workstation settings — surface and monitor height and monitor focal length — enable every user to preserve and easily restore their personal settings.

The monitor bracket supports large monitors weighing up to 50 lbs, responding to a growing interest in larger images. We have added acoustical properties to our wraparound privacy partition to reduce extraneous sounds and create a more quiet environment for concentration.

Ambient LED backlighting with dimmer control alleviates eye strain and improves the readability of images. A pop-up data port and USB unit is built into the work surface for convenient and tidy connection of almost any ancillary digital or electronic device. Multi-channel cable management keeps wires neat and unobtrusive and allows for important separation of power and electric wiring. An environmental heating and cooling system controlled at the workstation allows for direct regulation of temperature and alleviates heat generated by computer equipment.

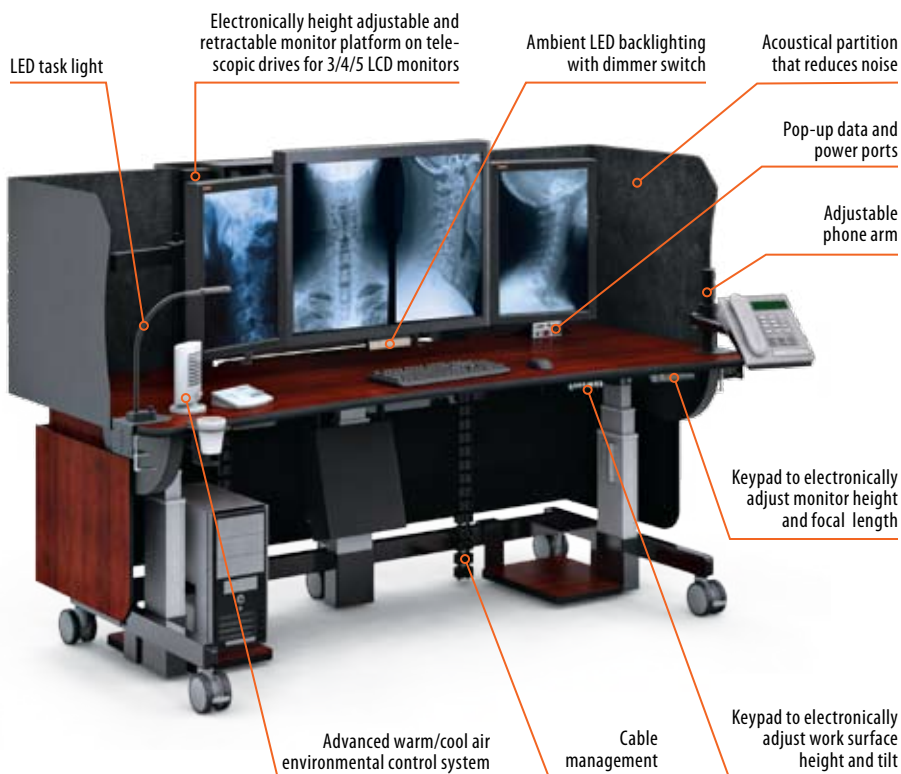

Deluxe Ergo Tier Cart™

We're pleased to raise the ergonomic standards bar and to offer radiologists well-designed, durable furniture that reduces the risk of strain and injury, while helping them maximize performance in their mission-critical healthcare role.

The **Deluxe Ergo Tier Cart™** is designed to meet the need for easy electronic adjustment, at the touch of a button, of the work surface height and independent monitor positioning for height and focal length, as well as work surface tilt within a 15° range of motion. Both seated and standing work positions are accommodated, and a digital readout for surface height is standard with the **Deluxe Ergo Tier™**.

Electronic Adjustment:

- SURFACE HEIGHT
- SURFACE TILT
- MONITOR HEIGHT
- FOCAL LENGTH

A. Deluxe Ergo Tier Cart™ 72"W x 36"D:

- Electronic adjustment of work surface height and tilt
- Electronic adjustment of monitor height and focal length
- AmbiTask Light Combo # AMBL001
- Adjustable Phone Arm # TA002
- Adjustable CPU Holder # CPU 13-25
- Ergonomic Foot Rest # FR002

B. Deluxe Ergo Tier Cart™ 72"W x 50"D:

- Electronic adjustment of work surface height and tilt
- Electronic adjustment of monitor height and focal length
- Two clamp-mount Monitor Arms # AFCFLEXOARM
- AmbiTask Light Combo # AMBL001
- LED Task Light # TAL400
- Adjustable Phone Arm # TA002
- Two mobile CPU cradles # CPU-02
- Two Wire Managers # WMF200



Ergo Tier Cart™

AFC's flexible, durable workstations designed with ergonomic intelligence for a wide range of users and needs, reduce stress and injuries and help radiologists and healthcare professionals work more comfortably and effectively.

The Ergo Tier Cart™ is available in different sizes and color options that accommodate virtually any location and workplace need. Electronic height adjustment maximizes operator comfort and efficiency. Digital readouts for console settings with four memory presets enable every user to preserve and easily restore optimal settings. The workstation can be enhanced with privacy partition, shelving, lighting, computer storage, and other accessories.

Electronic Adjustment:

- SURFACE HEIGHT
- MONITOR HEIGHT
- FOCAL LENGTH (optional)

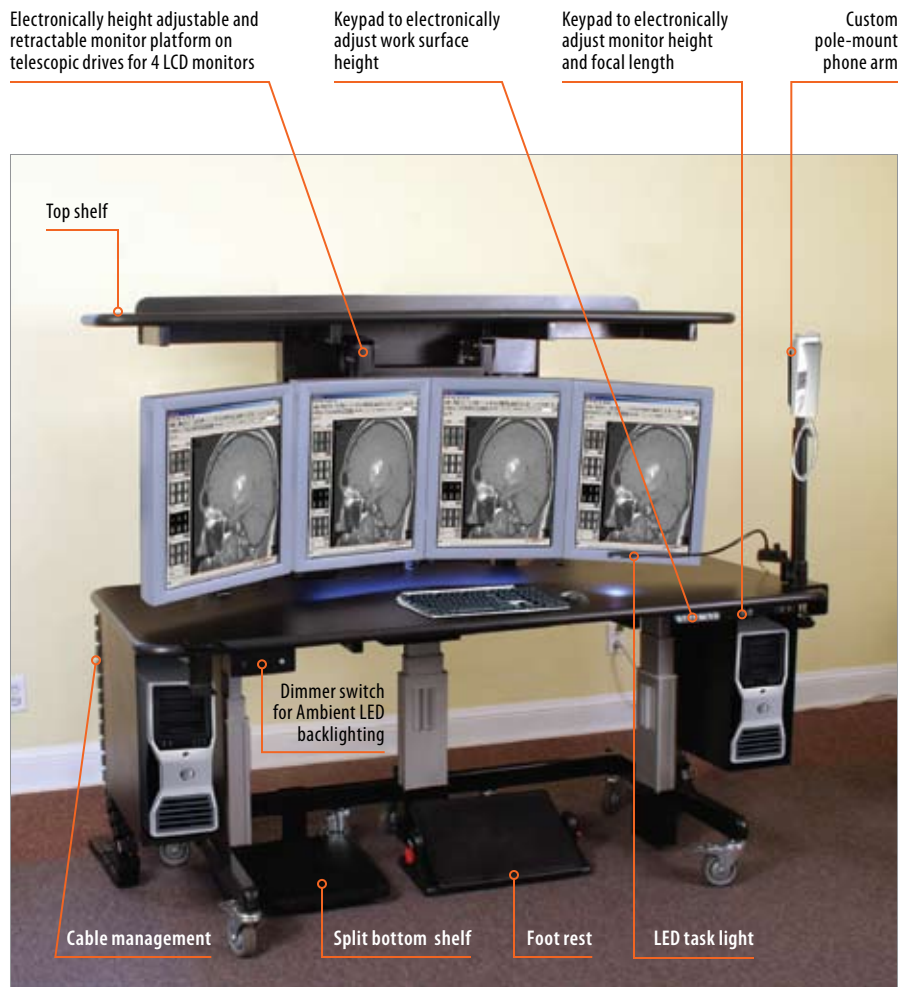

A. Ergo Tier Cart™ EFX 72"W x 36"D (top shelf and accessories are optional)

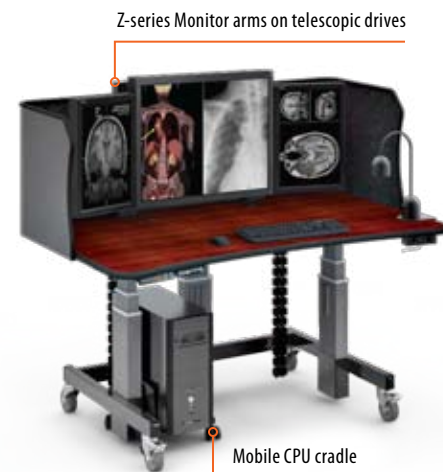

B. Ergo Tier Cart™ ZX 60"W x 36"D:

- Independent electronic height adjustment of work surface and monitor platform
- Z-series Monitor Arms on telescopic drives # AFCERGO3_Z
- Acoustical partition
- Clamp-mount task light # TAL200A with dimmer
- Mobile CPU cradle # CPU-02
- Two wire managers # WMF100

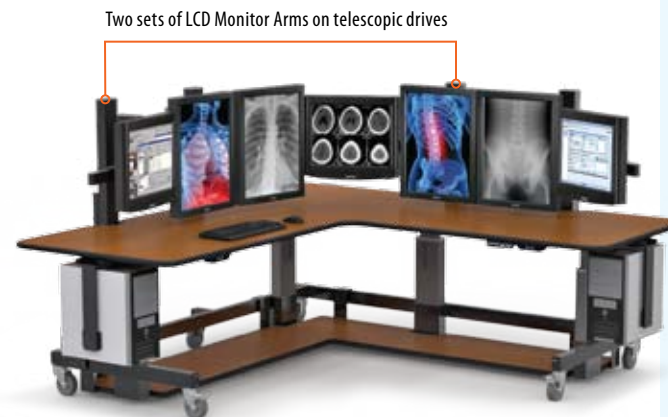

C. Corner Ergo Tier Cart™ FX 84"W x 84"W:

- Independent electronic height adjustment of work surface and monitor platforms
- Two monitor platforms on telescopic drives # AFCERGO3 & # AFCERGO05
- Two adjustable CPU Holders # CPU 13-25
- Bottom shelf



D. The JW Treadmill Desk™ 83"W x 56"D:

- Independent electronic height adjustment of work surface and monitor platform
- LCD Monitor Arms on telescopic drives # AFCERGO05



Dual Tier Cart™

The **Dual Tier Cart™** has two independently adjustable surfaces. With the simple touch of a button you can adjust the height of the monitors and work surface from a seated to a standing position. In the bifocal setting, the monitors are lower than the work surface, ensuring a comfortable viewing angle. This flexibility delivers optimum body positioning and comfort.

Electronic Adjustment:

- TIER 1 HEIGHT
- TIER 2 HEIGHT

The workstations shown below have Z-series monitor arms that allow manual adjustment of each monitor's focal length. An optional environmental heating and cooling system, controlled at the workstation, allows for direct regulation of temperature and alleviates heat generated by computer equipment.

Configure your own **Dual Tier Carts™** with our **INTERACTIVE BUILDER** at www.afcindustries.com/dualtier.

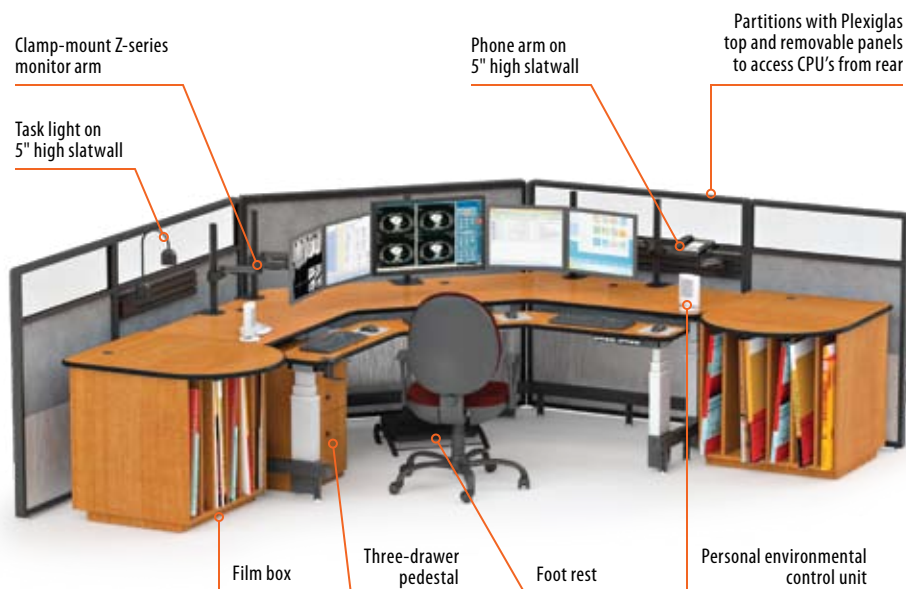

A. Corner Dual Tier Cart™

B. Dual Tier Cart™ 72"W x 44"D:

- Independent electronic height adjustment of both tiers
- Three Z-series Monitor Arms # AFCZ500-01
- Leg-mount CPU Holders # CPU-07



C. Dual Tier Cart™ 64"W x 64"D:

- Independent electronic height adjustment of both tiers
- Top shelf
- Z-series Monitor Arm # AFCZ500-02
- Back modesty panel
- Corner spit bottom shelf



D. Dual Tier Cart™ 72"W x 72"D:

- Independent electronic height adjustment of both tiers
- Two Z-series Monitor Arms # AFCZ566-02
- Two Wire Managers # WMF100
- Full bottom shelf

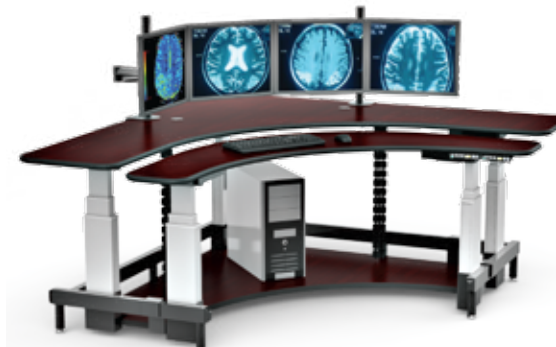

E. Dual Tier Cart™ 93"W x 46"D:

- Independent electronic height adjustment of both tiers
- Z-series Arms for one and two LCD monitors # AFCZ500-01 and # AFCZ500-02
- Split bottom shelves



Work Surface Shapes





Single Tier Cart™

Our height adjustable **Single Tier Carts™** come in wide variety of configurations, sizes and colors. The workstation shown below (image A) is loaded with a full array of electronics, power and cable management that facilitates performance, comfort, and ease of use. The Z-series monitor arms allow you to position the monitors at any viewing level, angle, and depth. A locking cabinet with slide-out shelf provides space to house the CPU and other radio equipment. A pop-up data port and USB unit are built into the work surface for convenient and tidy connection of almost any ancillary digital or electronic device.

Electronic Adjustment:
 ■ SURFACE HEIGHT

A locking cabinet with slide-out shelf provides space to house the CPU and other radio equipment. A pop-up data port and USB unit are built into the work surface for convenient and tidy connection of almost any ancillary digital or electronic device.

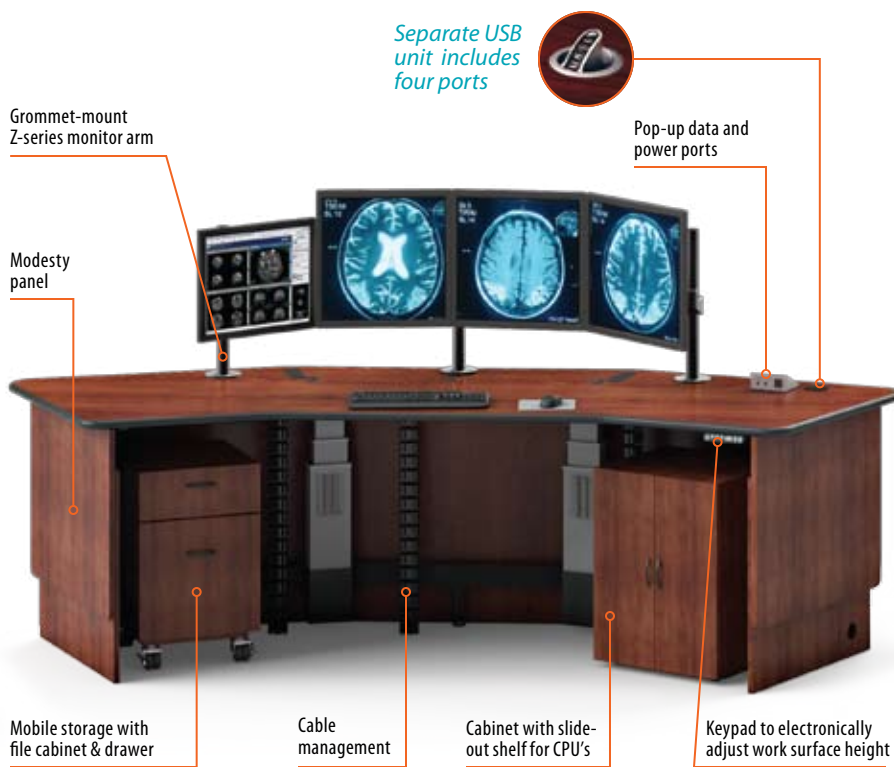

A. Single Tier Cart™ 108"W x 30"D (modesty panel and accessories are optional)

The **Single Tier Cart™** shown on the image B features the swinglift keyboard arm that allows for independent manual adjustment of the keyboard tray. Semi-round side extensions create an additional work area. The slatwall monitor system lets the user slide monitor arms horizontally. Front and rear doors provide full access to bottom CPU enclosures. Multi-channel cable management keeps wires neat and unobtrusive.

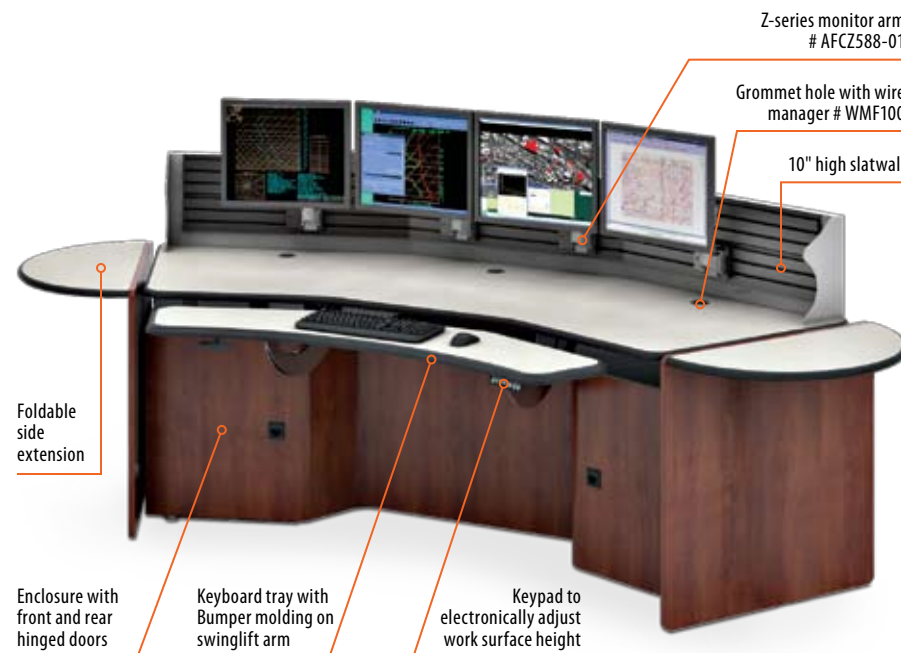

B. Single Tier Cart™ 116"W x 30"D



Fixed, lockable technology cabinets provide ample room for multiple large CPUs.

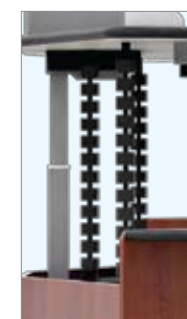

With direct access from the back of the console, our **Cable Management** connects directly to the underside of the work surface to seamlessly direct wires from floor to work surface.



The **Slatwall** is a great way for a multitude of accessories that can easily be maneuvered to create an unlimited number of combinations.

C. Single Tier Cart™
72"W x 72"W:

- Electronic height adjustment of work surface
- Flipper cabinet with three doors
- Three Monitor Arms # AFC02
- Keyboard Arm # KA6000 with tray # TR3000
- Two Phone Arms # TA002
- Gooseneck Task Light # TAL200A
- Two split bottom shelves
- Mobile Film box # FB-100
- Metal Film Box # FB-200



D. Single Tier Cart™
56"W x 54"W:

- Electronic height adjustment of work surface
- Phone Arm # TA002
- Retractable Pencil Drawer # PD002
- Partition
- Fluorescent Under-Shelf Light # TAL300F



E. Single Tier Cart™
96"W x 36"D:

- Electronic height adjustment of work surface
- Z-series Arms # AFCZ500-02 and # AFCZ500-03
- AmbiTask Light Combo # AMBL001
- Swinglift keyboard arm
- Partition with removable lower metal panel for back CPU access
- CPU enclosure with mobile platform



Mobile CPU enclosure allows for both front and back CPU access

Select a work surface shape from the right images, or have us customize a surface shape that best fits your requirements.

You can configure your own **Single Tier Carts™** with our **INTERACTIVE BUILDER** at www.afcindustries.com/singletier.

Work Surface Shapes



IntelliCart™

We also offer non-electric desks. Featuring cutting-edge design and flexibility, the **IntelliCart™** gives you the versatility and mobility you have been looking for. The carts have 16-inch deep top shelf and 18-inch deep bottom shelf edged with bumper molding. The work surface is manually height-adjustable in one-inch increments. Its soothing, fluid lines bring a relaxing touch to busy work environments. With an elegant yet simple design, it is a strong and comfortable workstation that will last a lifetime.

Work Surface Shape



A. IntelliCart™
72"W x 36"D:

- Top shelf
- Three clamp-mount Monitor Arms # AFC02
- Keyboard Arm # KA6000 with tray # TR2000 and sliding mouse tray
- Flushed bottom shelf



B. IntelliCart™
48"W x 30"D:

- Flipper cabinet with two doors
- Middle shelf
- Swinglift Keyboard Arm # KA7001
- Handle
- Flushed bottom shelf

Swinglift keyboard arm in seated position

Swinglift keyboard arm in standing position



C. IntelliCart™
36"W x 30"D:

- Top shelf
- Clamp-mount Monitor Arm # AFC02
- Swinglift Keyboard Arm # KA7001
- Flushed bottom shelf

SmartCart™

Our non-electric workstation designed and built with the radiologist in mind. The **SmartCart™** (image A) features a 30-inch high work surface edged with T-molding and two clamp-mount articulating arms for 4 LCD monitors.

Cabinet enclosures with mesh doors provide ample room for multiple CPU's and support both front and rear access, enabling easy installation and service. The middle partition has a removable lower metal panel for additional access. Four slatwalls for mounting phone arms, task lights, wire baskets, shelves, and other accessories.

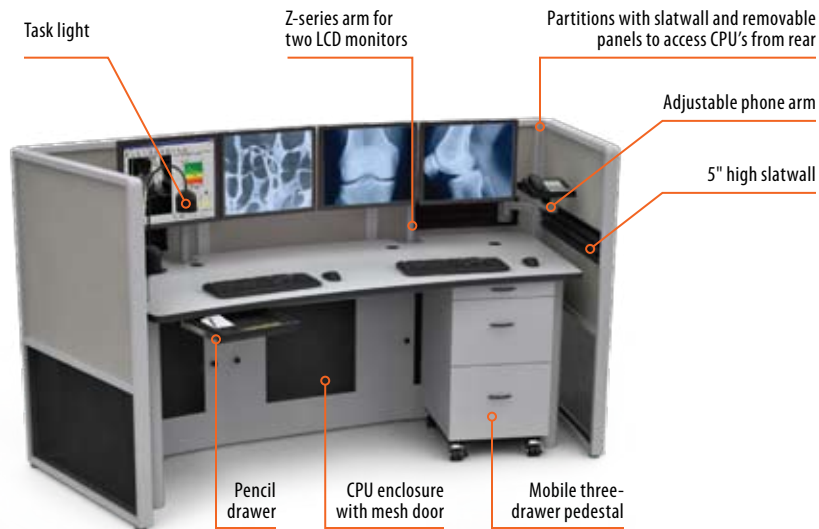

A. SmartCart™ 84"W x 32"D

The handsome work center shown below will embellish any workplace. The corner shape keeps all of your equipment within easy reach. The slatwall mounting system allows you to slide monitors, phone arm, or other accessories horizontally. Configure your own **SmartCart™** with our **INTERACTIVE BUILDER** at www.afcindustries.com/smartcart.

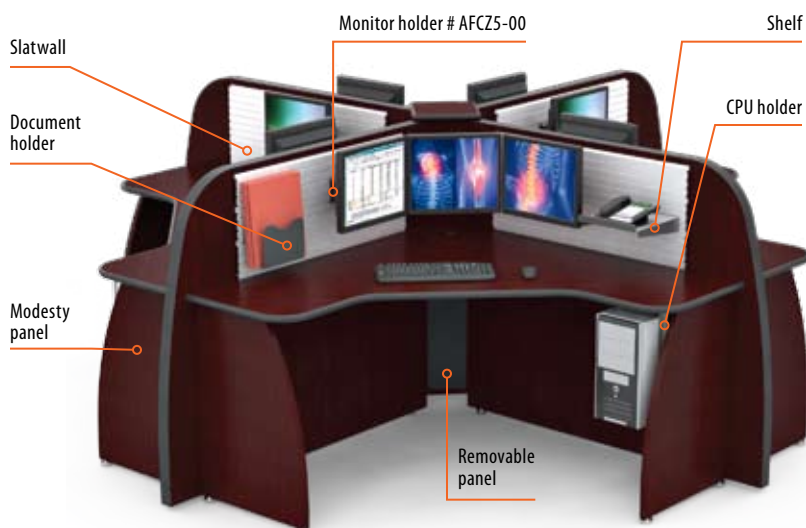

B. X-Series Desk 60"W x 60"W

C. SmartCart™ 60"W x 36"D:

- Z-series Monitor Arms # AFCZ500-02 and # AFCZ500-01
- Swinglift keyboard arm
- Task light # TAL200A with dimer
- Bottom shelf
- Two CPU cradles # CPU-07
- Two wire managers # WMF100



D. SmartCart™ 96"W x 72"W:

- Flipper cabinet with two doors
- Middle shelf
- Z-series monitor arm # AFCZ500-2
- Under-desk-mount pedestal with drawer and file
- Flushed bottom shelf



E. SmartCart™ 60"W x 24"D:

- Flipper cabinet with two doors
- Monitor Arm # AFC01
- Task Light # TAL200A
- Phone Arm # TA002
- Keyboard Arm # KA6000
- Keyboard Tray # TR2000 with sliding Mouse Tray
- Film Box # FB-100-1 and storage cabinet on bottom shelf
- Mobile CPU Cradle # CPU-02





Optimizing your mobile computing needs

Today's advancing technological world demands what we at AFC refer to as "Whenever ⇔ Wherever" access to data, including electronic medical records, radiology images, and more. The need has become ubiquitous, throughout all areas of healthcare facilities and professional functions — from radiology reading rooms to patient bed sides, operating rooms to conference rooms; in oncology, cardiology, nuclear medicine, labor and delivery, and more. AFC's array of durable mobile carts are designed to meet this growing need, while incorporating ergonomic features that make them adaptable to any user.

Our height adjustable units are available in footprints as small as 19 inches for easy maneuvering in tight places. Security features protect both sensitive patient information and computer equipment. Our carts are built from materials for thorough disinfection. Long-lasting batteries can be loaded so that carts can move from area to area without being connected to electrical outlets providing uninterrupted power to your workstation wherever, and whenever you need it.

Whatever your need is, AFC can build a mobile cart solution for you.

PC Cart™

Our **PC (Point-of-Care) Carts™** are designed for maximum flexibility and streamlined movement. They combine enhanced functionality with the hallmark durability and ergonomic design of AFC's mobile work stations. Our **PC Carts™** enables physicians to bring advanced computer technology to the bedside, operating room and any other location where patients will benefit from today's medical computer applications.

The **PC Carts™** feature a low profile, small footprint, pneumatic (optional electronic) height adjustment, and support all-in-one computers as well as separate thin client and monitor.

Pneumatic Adjustment:

- **SURFACE HEIGHT**

For maximum portability, the carts can accommodate a battery power source (go to www.afcindustries.com/Batteries for power supply options). Select from our range of monitor arms, CPU holders, keyboard trays and other accessories to complete your configuration.

Features and Benefits

- Pneumatic height adjustment
- Thorough disinfection for clean room use
- Supports all-in-one computer as well as separate thin client and monitor
- Mounting for all-in-one computer or standard monitor VESA (75/100)
- Rounded phenolic, HDPE¹, laminate, or metal work surface
- Seamless integration of handles into the work surface on all four corners for easy grip from any user position



Optional

- Electronic height adjustment
- Keyless electronic lock for utility drawer and divider to facilitate administration of care in two-patient rooms
- Phenolic retractable keyboard tray with ergonomic negative and positive tilt and swivel
- Power supply
- Wire manager, mouse holder, wire basket, scanner holder, and additional accessories available

¹ High-density polyethylene (see inside back cover for more information)



PC Cart™ 910

The **PC Cart™ 910** combines a streamlined look and enhanced functionality with the hallmark durability and ergonomic design of AFC's mobile work stations. With an all-in-one computer, the height-adjustable **PC 910** offers a battery that can run for up to 25 hours before recharging. UL 60601-1 compliant, it is safe to use throughout facilities. Fleet management software allows for IT monitoring, management, and programming of carts for location, battery status, and scheduling of computer shutdown, recharging and maintenance.

A phenolic/HDPE work surface with rounded corners enhances safety and appeal. Cutout handles on all corners facilitate grip, access from any user position, and range of motion. The retractable phenolic keyboard tray features ergonomic tilt, swivel, and a sliding mouse tray for both left- and right-handed users.

Specifications

- Pneumatic height adjustment
- Rounded phenolic/HDPE work surface for greater safety, comfort, and appeal
- Keyless electronic lock for utility drawer and divider to facilitate administration of care in two-patient rooms
- Phenolic retractable keyboard tray with ergonomic negative and positive tilt and swivel
- Mouse tray slides to accommodate left- and right-handed users
- 5" casters with round tread wheels for ease of movement
- Footprint size: 20"W x 24"D
- Work surface size: 24"W x 24"D
- Keyboard tray size: 19"W x 8"D
- Height of work surface from the floor: ~30" to 42"

Standard Colors

- Putty
- Gray
- Black

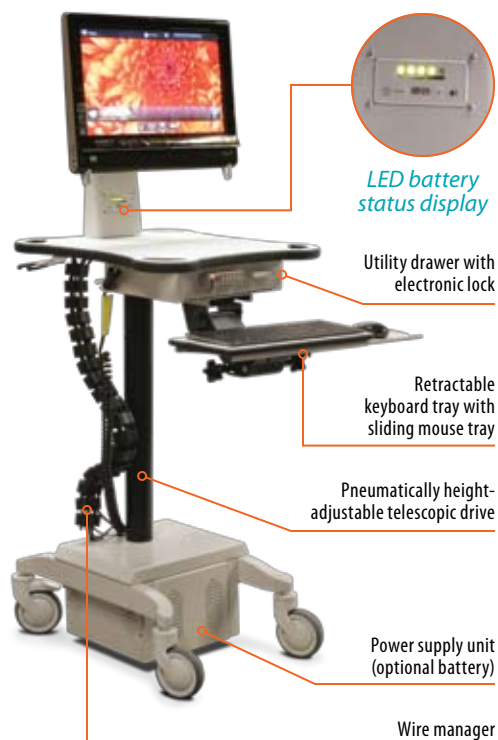

A. PC Cart™ 910

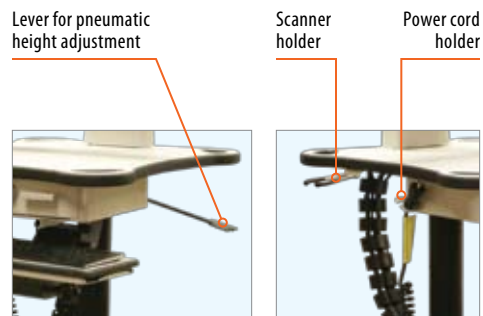

PC Cart™ 800

This multi-purpose and functional cart is ideal for all healthcare business and service sectors. The **PC Cart™ 800** has laminate, phenolic, or HDPE work surface and a rectangular base of 19"W x 20"D. This mobile computer cart features a pneumatic sit-to-stand or user-to-user height adjustment.

Completely modular. Select from our full range of monitor arms, CPU holders, keyboard trays and other accessories to complete your configuration.

Easily adapted for use with CPUs, tablet PCs or notebook computers, it can also provide video teleconferencing capability with minor add-ons.

Available in several colors to match most color schemes or to stand out for easy identification.

Specifications

- Pneumatic height adjustment
- Laminate/phenolic/HDPE work surface with handles
- Work surface size: 22 ½"W x 20"D
- Footprint size: 19"W x 20"D
- 4" twin casters
- Height of work surface from the floor: ~30" to 42"

Optional

- Seamless integration of handles into the work surface on the corners for easy grip
- Retractable keyboard tray

Laminate Colors

- Putty
- Gray
- Black
- White
- Red
- Green
- Blue



A. PC Cart™ 800 with clamp-mount monitor arm # AFCZ588-01

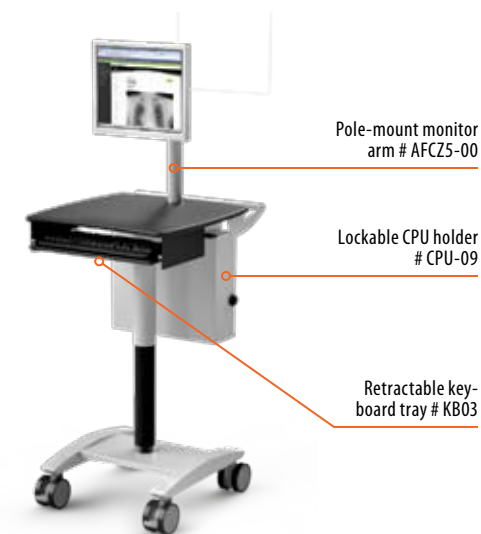

B. PC Cart™ 800 with pole-mount monitor arm # AFCZ5-00

Telescopic Cart™

The **Telescopic Cart™** is designed to accommodate tight spaces. The work surface is electronically height-adjustable to enhance comfort and ease of use, whether the operator is seated or standing. Mobile on stable locking casters, the strong, durable **Telescopic Cart™** can be stationed wherever needed and makes adding an extra workstation easy and affordable. Available in different width and depth combinations, the cart can accommodate up to two flat panel monitors.

All sizes are customizable with grommet-mount or clamp-style monitor arms, multiple laminate finishes and colors, keyboard arms and trays, and larger casters for two additional inches of height.

Configure your own **Telescopic Cart™** with our **INTERACTIVE BUILDER** at www.afcindustries.com/telescopiccart.

Electronic Adjustment:

▪ SURFACE HEIGHT

Features and Benefits

- Cold-rolled 11-gauge steel frame with epoxy-powder-coated finish
- Particle-board-core top with your choice of high-pressure laminate finish
- Chemical-resistant phenolic top and bottom surfaces available
- Work surface is electronically height-adjustable with optional electronic tilt
- Multiple colors available (for standard colors, see page 35)
- Four four-inch casters (the front two are locking)
- Additional accessories available

Specifications

- Width: 24", 30", 36"
- Depth: 24", 30", 36"
- Height of work surface from the floor: 30" to 46"

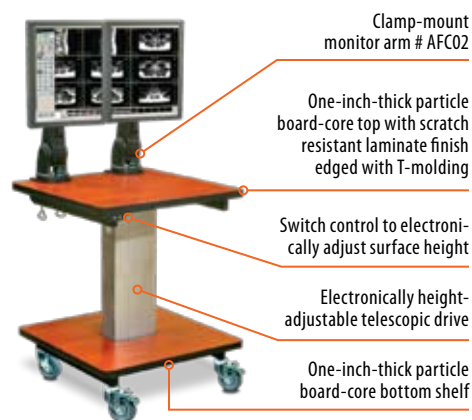

A. Telescopic Cart™
24"W x 24"D

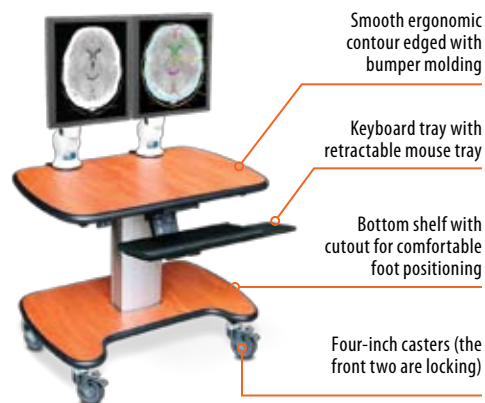

B. Telescopic Cart™
36"W x 24"D



12.2" vertical travel of the **Swinglift Keyboard Arm** allows use of keyboard and mouse while seated or standing up



C. Telescopic Cart™
LTC4236-01
42"W x 36"D:

- Grommet-mount Z-arm # AFCZ588-02
- Swinglift Keyboard Arm # KA7001
- CPU Holder # CPU 13-25
- LED Task Light # TAL400

Work Surface Shapes¹



¹ Availability of shape depends on size of the cart



D. Telescopic Cart™
30"W x 30"D:

- Chemical-resistant phenolic work surface and bottom shelf
- Grommet-mount twin Monitor Arm # AFCPOLE2MH-1



E. Telescopic Cart™
24"W x 24"D:

- Clamp-mount Monitor Arm # AFCPOLE
- Retractable Keyboard Tray # KB01
- CPU Holder # CPU-99
- Wire Basket # WB-100
- Wire Manager # WMF100



Mounting solutions make the most of limited-space and decentralize data access

High traffic areas. Tight places. Operating rooms and emergency rooms. Inside and outside patient rooms. These are just some of the areas that are perfectly suited for AFC's variety of mounting solutions. Height-adjustable versions for seated or standing positions. Adaptable to any user. Making empty wall space productive.

Decentralizing the availability of data for a greater return on investment in plant and human capital.

Combo Arms AFC7808 and AFC7810 Series

The **AFC7808** and **AFC7810 Series** offer height-adjustable, low-profile, user-friendly solutions for access to electronic records where space is at a premium. The wall mount accommodates most operators, in sit-to-stand positions. When not in use, it folds up neatly to the wall, tucked away and unobtrusive.

The flexible **AFC7808** and **AFC7810 Series** are designed with the ergonomic intelligence, strength, durability, and thorough disinfection properties like other AFC products, while offering an easy-to-operate tool for boosting productivity. They are pneumatically height-adjustable within a 12-inch range, and can be locked in any position you chose. Full range of swivel motion at each joint comfortably accommodates different positions and applications, such as sharing information with patients and other professionals in proximity.

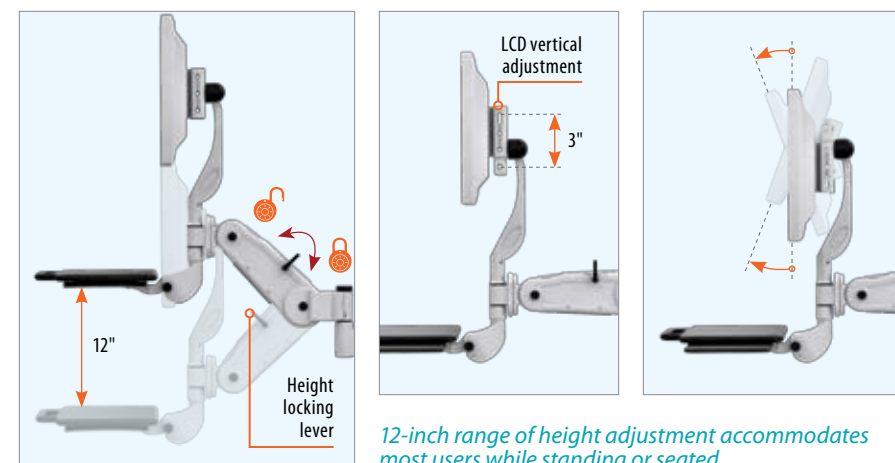
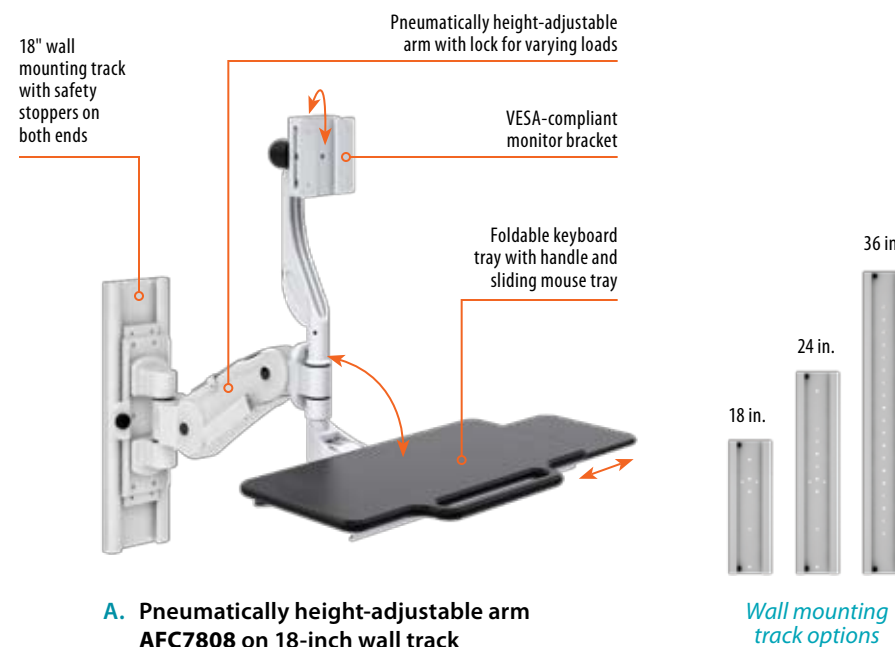

Features and Benefits

- Light-weight aluminum construction for easy operation
- Anti-microbial coatings for thorough disinfection for safe use throughout medical facilities
- Sit-to-stand work positions
- Height locking mechanism at any position for safety, stability, and varying loads
- Full range of swivel motion at each joint
- Keyboard folds for low profile and has a safety lock
- 12-inch range of height adjustment for accommodation of most users
- 34" fully extended from the wall
- 10" when retracted and folded to the wall
- VESA 75/100 compliant monitor bracket with horizontal and vertical tilt and 3-inch range of height adjustment
- Mouse holder is included
- Integrated wire management
- Standard color: Gray (call for custom colors)
- Can be mounted directly on a wall or desk
- Option of supplemental 12" or 20" extension arm
- Arm vertically adjusts on 18"; 24" or 36" wall track (wall track is optional)

Keyboard tray with integrated handle easily folds up, saving space when not in use

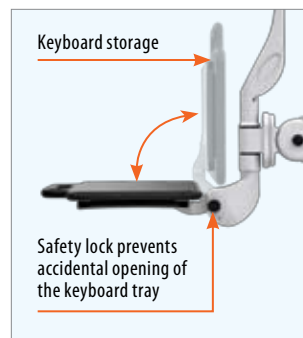

Mouse tray slides to accommodate left and right-handed users

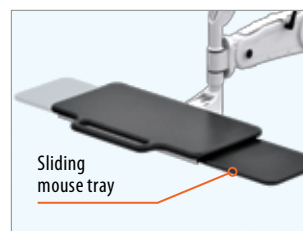

With the keyboard folded up, total system depth is as little as about 8"

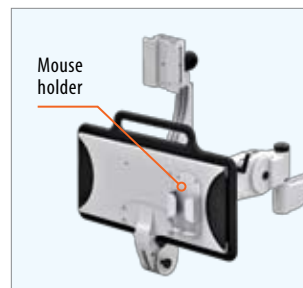

Clean, concealed and neat routing of cables through the cable management system

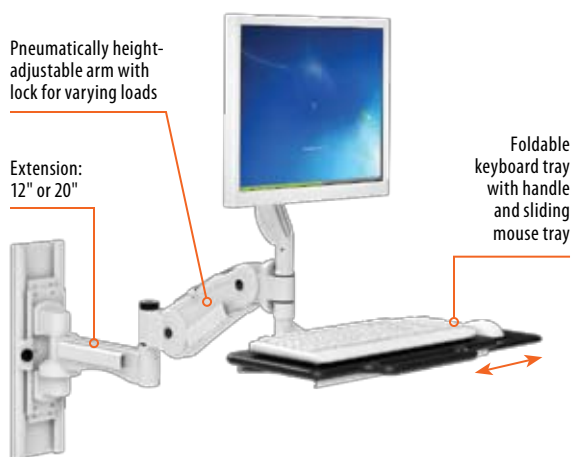
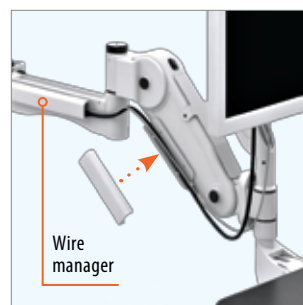

B. Combo arm AFC7808 with 12-inch extension on 18-inch wall track

LCD vertical adjustment

Pneumatically height-adjustable arm with lock for varying loads

18" wall track with safety stoppers on both ends

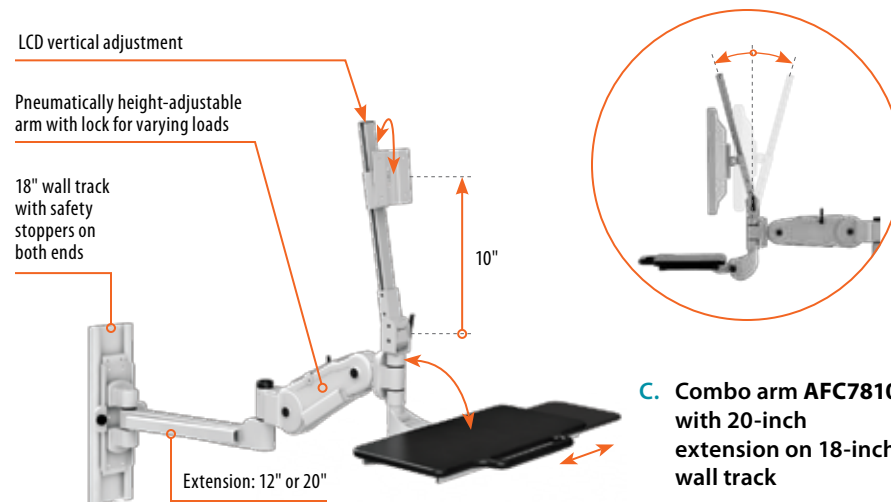

C. Combo arm AFC7810 with 20-inch extension on 18-inch wall track

Mounting Options



Vertical mounting



Horizontal mounting



Desktop mounting

More Mounting Solutions with AFC7808 Series

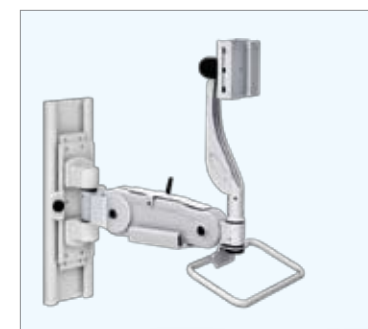

Monitor arm

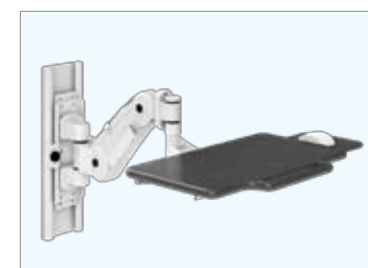

Keyboard arm

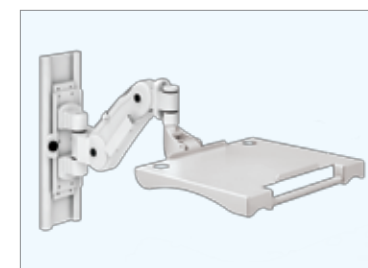

Laptop arm

Wall Mounts

AFC Wall Mounts are perfect for high-traffic areas because of their compact design. This space-saving solution is also ideal for areas where multiple operators use a single computer workstation.

Our monitor and keyboard wall mounts enable you to adjust both the keyboard and monitor height from a seated to standing position, as well as from left to right. Configure your own **Wall Mount** with our **INTERACTIVE BUILDER** at www.afcindustries.com/wallmount.

Features and Benefits

- All components are individually adjustable in increments of 2"
- Safety stoppers at both ends
- Spring-loaded locking mechanism for simple and easy height adjustment
- VESA-compliant monitor holder that can be adjusted from portrait to landscape view and tilted to avoid glare
- Foldable and retractable keyboard arm and mouse tray
- Adjustable CPU holder (3 1/2"– 8 1/2"W, 13"– 25"H)
- Multiple colors available (for standard colors, see page 35)
- Additional accessories available (see page 30)

Optional

- Horizontal or vertical positioning
- Double monitor holder on single track (see "Optional Monitor Arms for Wall Mounts")
- Horizontal track for multiple monitors
- UPS Holder
- Mouse Holder

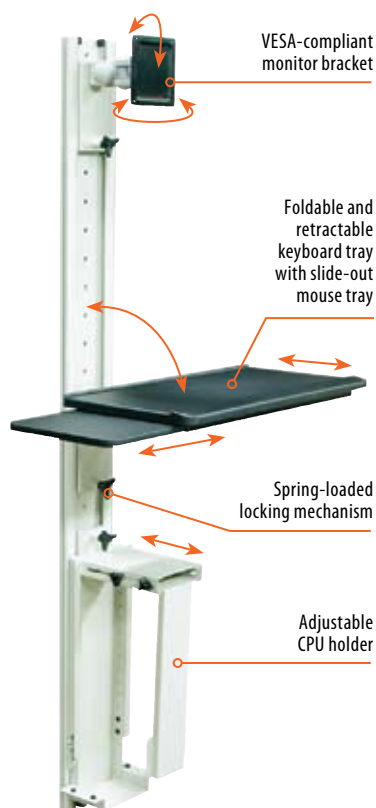

Vertical positioning

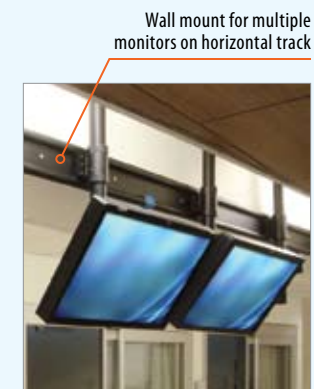
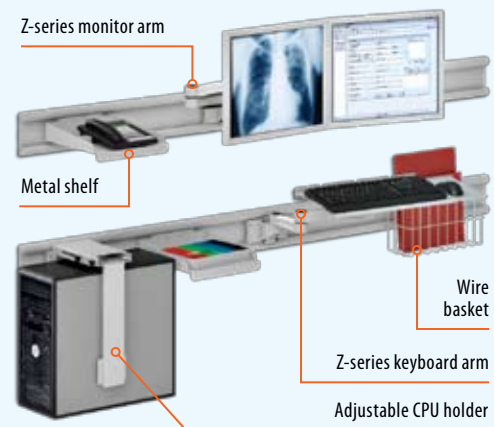

Horizontal positioning



A. Wall Mount # WM36-NH-1F-1KS-C101



B. Wall Mount # WM56-2FZ-KB82R-U-C13_25



C. Wall Mount # WM56-1F-KBZ-Sh-C101



Optional Monitor Arms for Wall Mounts



Monitor arm # AFCZ5-00



Twin monitor arm # 2MH



Z-series monitor arm for one monitor



Z-series monitor arm for two monitors

Partitions

Complete your work area using AFC **Partitions**. These partitions absorb sound and provide privacy. They also prevent interference from monitors or other light sources. They can be manufactured with a tinted or clear Plexiglas panel across the top so operators can see outside of their "cubicle."

AFC offers both free-standing partitions and partitions affixed to the floor or cart. Our partitions can be configured to suit your application.



- A. Partition 60"W x 60"H with sound-absorbing fiber
- B. Partition 60"W x 72"H with tinted Plexiglas top



C. Partitions affixed to the floor



- D. Partitions affixed to the floor:
 - Light and sound barrier fiber top
 - Removable lower metal panel allows back CPU access
 - Built-in continuous cable management

Features and Benefits

- One-inch sound-absorbing fiber with reflector on one side
- Cold-rolled 11-gauge steel frame with epoxy-powder-coated finish
- Prevents light interference
- Can be used as a tack board
- Multiple colors available (for frame colors, see page 95)
- ¼" thick free-standing base

Specifications

- Width: 36", 48", 60", 72"
- Height from the floor: 60", 72"

Optional

- ⅛" tinted or clear Plexiglas top
- Fiber top with removable lower metal panel and built-in continuous cable management
- Free-standing, mobile (2" twin casters), or affixed to the floor/cart

Fabric Standard Colors



LCD Monitor Arms/holders

Desktop Series



Z-Series

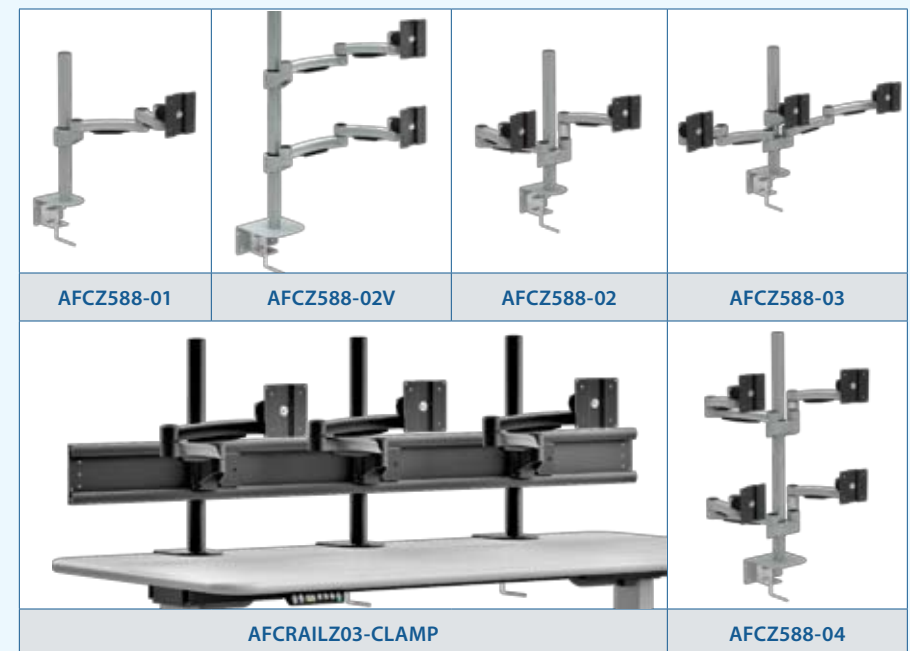

Wall Mount Series



CPU Holders

Desk or wall-mount	
CPU 13-25	CPU-09
Wall-mount CPU-CS909	Wall-mount CPU-919
Wall-mount CPU-101	Mobile CPU Cradle CPU-02

Lighting

LED Task Light TAL400	Task Light TAL200A	AmbiTask Light Combo AMBL001
LED Backlight TAL500		

Cable Management & Power Solutions

 Length: 12", 24", 36"	 Length: 30", 60"	 Diameter: 1/2"	
Cable Manager WM201	Wire Managers WMF100 and WMF200	Cable Wrap WM-400	Retractable Power Cord RPC-101
A - 1 7/8" W x 1" H			
 B - 7/8" W x 1/2" H			
Cable Manager WM100		Portable AC Power System PS-TL-1	Data & Power Ports DPA-01

More Accessories

 Retractable Mouse Tray	 Ergonomic shape	 Swinglift	 Retractable	
Keyboard Arm & Tray KA6000 & TR2000	Keyboard Arm & Tray KA6000 & TR3000	Keyboard Arm KA7001	Keyboard Tray KB03	Keyboard Arm & Tray WM-TR-MZ
	 12"W x 14"D x 1.5"H			
Metal Film Box FB-100	Pencil Drawer PD002	Wire Basket WB-100	Cup Holder MCH-100	Mouse Holder M001
Phone Arm TA002	Dictation Arm TA003B	Air Fan FanR1-100	Ergonomic Foot Rest FR002	Palm Rest PAL1000

Storage Accessories

 30", 36", 48", 60", 72" or 84" wide			
Flipper Cabinet FC	Wood Clipboard Holder CLPHLD-W		
One Door Cabinet D0123	Two Door Cabinet D0124	Wood Film Box FB-100-1	Mobile Film Box FB-100
Metal Pedestal P3BBF19MF	Wood Pedestal with lock P3BBF19MF	Slatwall	Printer Shelf/Rolling Shelf EXSHR META

FREE on-site consultation

At AFC we want to get it right the first time, every time, to create a great custom environment for our Customers. That's why we will come to you to ensure we are maximizing your space and that everything is measured up just right. We will work with your team, at no charge to you, from the beginning to the end of your project.

FREE project support

Our team is here to assist you with your vision. We have the experience to help with your project and pride ourselves in going above and beyond to not just meet, but exceed your expectations.

FREE design service

We want to use our many years of experience creating spaces to take full advantage and help you go beyond your imagination. With some of the most mechanically advanced products, we will help you achieve your goals, all at no additional cost to you.

Customization

AFC can easily customize all products to adapt to your professional and individual requirements. Whether you need help choosing the right components to configure a product or are considering a complete room redesign, our staff is committed to offering you assistance every step of the way.

Outstanding customer support

Our experienced sales and engineering teams are here to walk you through the process from the smallest to largest jobs. Building rapport with our customers is a driving force throughout the relationship and is maintained during the entire project including follow-up.



Anti-microbial paint

AFC now offers the added protection of anti-microbial powder-coat finishes on its products to provide protection against a broad spectrum of micro-organisms. When applied to mobile carts, wall mounts, and work stations the risk of spreading harmful bacteria and viruses between patients and health care workers is greatly reduced, according to doctors using the anti-microbial powder coating in their hospitals and laboratories.

High-density polyethylene (HDPE) top now available with antimicrobial protection

A new kind of antimicrobial protection upgrade now available in many of AFC's polymer sheets, slabs and massive shapes. HDPE helps products stay cleaner between cleanings and inhibits the growth of product-damaging microorganisms, including bacteria, algae and fungi on the surface. Microbe cell walls that come into contact with HDPE are destroyed on contact, without creating opportunities for adaptive or resistant strains to form. Because the antimicrobial agent is bonded at the atomic level throughout the sheet, it will not leach out of the product. This means the agent retains its effectiveness throughout the life of the product and does not harm the environment.

It is safe, non-toxic and non-hazardous to ship and handle. The product is EPA-registered and listed with the FDA as a modifier to medical devices.

Products made using AFC's polymers with HDPE are easy to clean, disinfect and keep hygienic using standard cleaning procedures. Constant use of cleaning solutions will not affect any polymer.

STANDARD COLORS

Laminate



Black

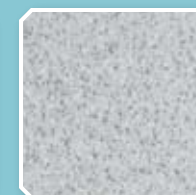

Speckled Gray

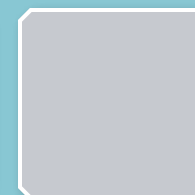

Gray

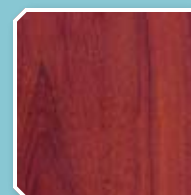

Mahogany



Wild Cherry

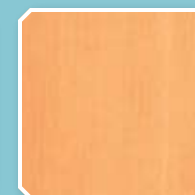

Natural Pear

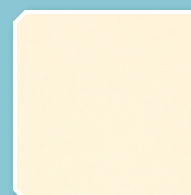

Putty

For any other color call us at 1.800.663.3412

Molding



Black



Gray

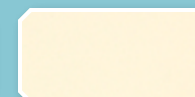

Putty

Frame

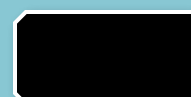

Black



Gray

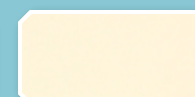

Putty



*Use our **Room Layout Designer** to see how you can create an ergonomic environment with AFC's products*



13-16 133rd Place • College Point • NY 11356

toll free: 1.800.663.3412

t: 1.718.747.0237

f: 1.718.747.0726

www.afcindustries.com



We deliver our products fully assembled to ensure maximum quality and convenience for our customers.



Scan here with your smart phone to visit our website

