

ADVERTISING

INFORMATION TECHNOLOGY



PC910-303 ▶
(page 8)

www.afcindustries.com

FURNITURE

afc INDUSTRIES, INC.
Solution creators for working environments™



Health Information Technology involves the collection, storage, access and exchange of health information in an electronic environment. The acceptance and widespread use of Health IT within the healthcare arena will improve the quality of health care, prevent medical errors, reduce health care costs, increase administrative efficiencies, decrease paperwork, and expand patient access to affordable health care.

But at what price to the Worker and the Healthcare System? Studies have shown, and research has confirmed, that without the proper ergonomic tools and environments, the Healthcare workforce is at risk for serious, costly and debilitating Repetitive Stress Injuries.

Since 1994, AFC Industries, Inc. has designed and manufactured a diverse line of ergonomically designed workstations, point-of-care carts, wall mounts, rack systems, video-conferencing carts and i-Centers™ for the Healthcare and IT professional. These height adjustable units guarantee the right height for standing as well as traditional sitting levels which can accommodate a diverse workforce to enhance performance, comfort and satisfaction in this fast-paced modern work arena.

Whether you require assistance in choosing the appropriate components to configure a product or a complete department redesign, our staff of engineers and ergonomic design experts is available to provide you with the solutions you need for your projects.

Whatever your needs, AFC Industries has the solution! Remember too, that additional designs and models are available on our website at www.afcindustries.com.

Contents

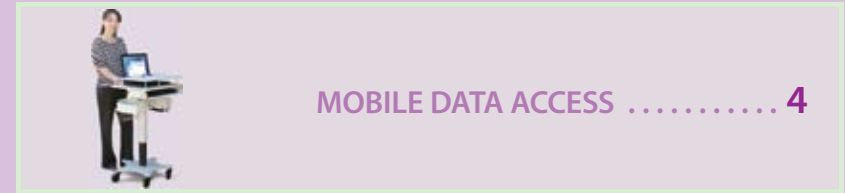

MOBILE DATA ACCESS 4

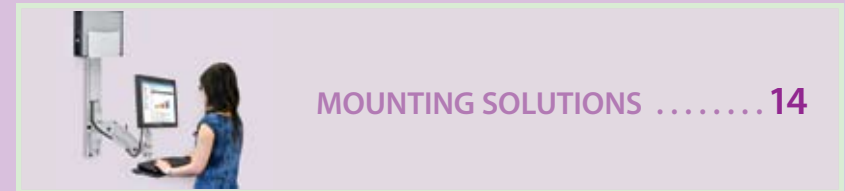

MOUNTING SOLUTIONS 14

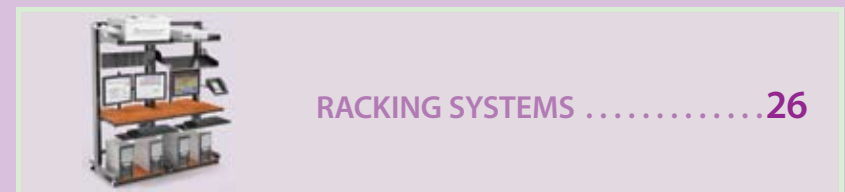

RACKING SYSTEMS 26

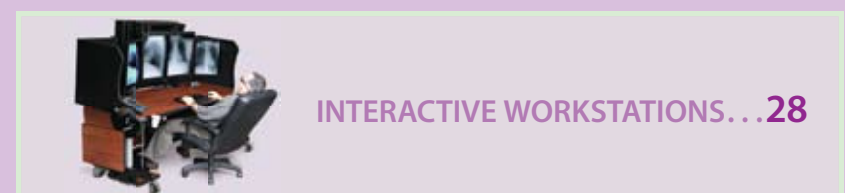

INTERACTIVE WORKSTATIONS... 28



ACCESSORIES 30

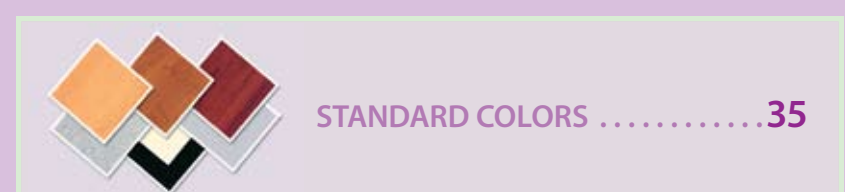

STANDARD COLORS 35

Data access and mobile computing needs

Mobile carts bring critical information to Point-of-Care locations throughout Healthcare facilities. Whether it involves admissions, pharmaceutical, radiological or tele-health video conferencing, daily patient care decisions must be accurately made and supported by the most current data available. AFC's array of durable mobile carts is designed to meet this growing need, while incorporating important ergonomic features that make them adaptable to any user.

Our height adjustable units are available with small footprints for easy maneuvering in tight places. Security features protect both sensitive patient information and computer equipment and our carts are built from materials for thorough disinfection. Long-lasting batteries (Hot Swappable / LiFe / SLA Power Supply) can be loaded so that carts can move from area to area without being connected to electrical outlets providing uninterrupted power to your workstation wherever, and whenever you need it.

Whatever your need is, AFC can build a mobile cart solution for you.



PC Cart™

Our **PC (Point-of-Care) Carts™** are designed for maximum flexibility and streamlined movement. They combine enhanced functionality with the hallmark durability and ergonomic design of AFC's mobile work stations. Our **PC Carts™** enables physicians to bring advanced computer technology to the bedside, operating room and any other location where patients will benefit from today's medical computer applications.

The **PC Carts™** feature a low profile, small footprint, pneumatic (optional electronic) height adjustment, and support all-in-one computers as well as separate thin client and monitor. For maximum portability, the carts can accommodate a battery power source (go to www.afcindustries.com/Batteries for power supply options). Select from our range of monitor arms, CPU holders, keyboard trays and other accessories to complete your configuration.

Features and Benefits

- Sit-to-stand pneumatic height adjustment
- Thorough disinfection for clean room use
- Supports all-in-one computer as well as separate thin client and monitor
- Mounting for all-in-one computer or standard monitor VESA (75/100)
- Rounded phenolic, HDPE¹, laminate, or metal work surface
- 5" casters with round tread wheels or 4" twin casters

¹ High-density polyethylene (see page 34 for more information)

Optional

- Electronic height adjustment
- Keyless electronic lock for utility drawer and divider to facilitate administration of care in two-patient rooms
- HDPE retractable keyboard tray with ergonomic negative and positive tilt and swivel
- Power supply, wire manager, mouse holder, wire basket, scanner holder, and additional accessories available
- Anti-microbial finish (see page 34 for more information)

Standard Colors

- Putty
- Gray
- Black

HDPE Colors

- Gray
- Black²

² Available with anti-microbial finish

PC Cart™ 910

The **PC Cart™ 910** delivers data access wherever it is necessary. It is available with either a **pneumatic or electronic** height adjustment feature. With an all-in-one computer, the height-adjustable **PC 910** offers a battery that can run for up to 25 hours before recharging. UL 60601-1 compliant, it is safe to use throughout facilities. Fleet management software allows for IT monitoring, management, and programming of carts for location, battery status, and scheduling of computer shutdown, recharging and maintenance.

A phenolic/HDPE work surface with rounded corners enhances safety and appeal. Cutout handles on all corners facilitate grip, access from any user position, and range of motion. The retractable phenolic keyboard tray features ergonomic tilt, swivel, and a sliding mouse tray for both left- and right-handed users.



Supports separate thin client and monitor

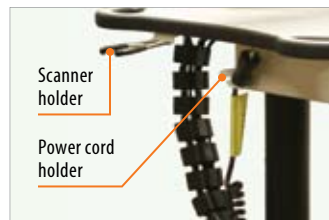

PC Cart™ 900

This unit's 20"x22" footprint is ideal for high traffic areas where the base width is crucial for maneuvering between stations or around equipment. It has the same **pneumatic** height adjustment features and ease of mobility as larger models, the **PC Cart™ 900** easily adapts to the end users ergonomically and its locale environmentally.

Available with an optional scanner holder and additional accessories (see page 32), the **PC Cart™ 900** can easily adapt to all work situations. It's sleek, yet durable, quad-point base has a small footprint and an overall height of less than 6 inch from the floor.



PC Cart™ 800

This multi-purpose and functional cart is ideal for all healthcare business and service sectors. The **PC Cart™ 800** has laminate, phenolic, or HDPE work surface and a rectangular base. This completely modular computer cart features a **pneumatic** sit-to-stand or user-to-user height adjustment.

Select from our full range of monitor arms, CPU holders, keyboard trays and other accessories to complete your configuration. Available in several colors to match most color schemes or to stand out for easy identification.

Laminate Colors

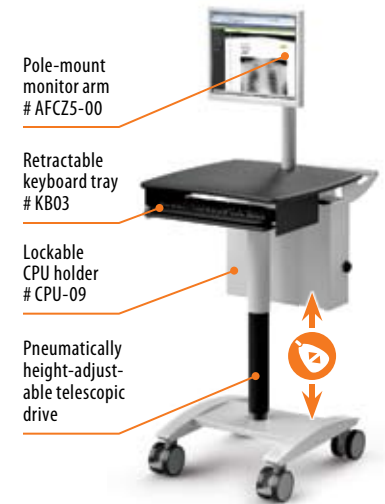

PC Cart™ 500

This cart has an all-metal body for easy cleaning and disinfecting. The **PC Cart™ 500** is available with **electronic or pneumatic** height adjustment and with or without battery power source (go to www.afcindustries.com/Batteries for power supply options).



A. PC Cart™ 500 with electronic height adjustment and power supply



B. PC Cart™ 500 with pneumatic height adjustment and power supply shelf



The Virtual Reality of Telemedicine

The traditional method of providing healthcare is to bring the patient to the doctor. More recently, medical technology has enabled us to bring the doctor to the patient. Increasingly, the point of patient care is moving from inside the walls of the hospital, which is the most expensive place to deliver care, to outside those walls, to lower cost venues while seeking to improve the quality of care and the patient's experience. Thanks to the introduction of high definition video conferencing, and hi-speed network connectivity, the virtual is becoming the reality.

AFC Industries has created highly mobile and ergonomic solutions especially for telemedicine. From something as simple as discussing a case over the telephone, or as complex as using satellite technology and videoconferencing equipment to conduct a real-time consultation between medical specialists in two different countries, our telemedicine carts can fit all situations. Available in a variety of sizes and shapes and equipped with camera holders, these units have become a mainstay in Healthcare IT departments.

Telemedicine Video Cart PC910-303

Our newest **electronically** height adjustable telemedicine cart **PC910-303** provides a fully integrated, mobile computing workstation designed for enhanced efficiency when health services through advanced applications are necessary.

Medical and non-medical devices can be easily connected to the carts systems' enabling high definition, real-time images to be shared providing the best diagnosis and care regardless of geographical or physical constraints. The combination of a compact design with a strong ergonomic focus makes this telemedicine cart ideal for point-of-care applications.



Telemedicine Cart TMC300

The telemedicine cart **TMC300** is a **pneumatically** height adjustable unit with an optional battery power source for true mobility. It is available with standard VESA-compliant mounting brackets (75/100), a locking drawer, camera mount and room for an all-in-one or a thin client computer. Sleek, efficient and easy to move with the integrated handles and four 4-inch casters.



Telemedicine Cart XPC1926

The **XPC1926** cart comes with two **pneumatically** height adjustable surfaces. Fully articulating VESA-compliant monitor arms, a spacious 15"W x 11"D x 4"H locking drawer, retractable keyboard tray, enclosure for CPU and the battery power source; and camera mount makes this cart an ideal unit for video conferencing.



Plasma Cart™ XLCD200-01

The **Plasma Cart™** is ideal for meetings, presentations, seminars, conferences and signage. Accommodating up to a 55" flat screen (subject to vary), this stable unit is a perfect solution for data and video access as you bring your large flat screen and necessary electronic equipment to where it is needed. All the components of the Plasma Cart are height adjustable. Internal wire management is built in behind easy-to-remove access panels.



Pole Cart™ MPC200

A truly customized item. The **Pole Cart™** begins as a blank canvas with a wheeled base and main pole assembly. **Everything you select to include becomes height adjustable and can rotate 360° around the pole.** Monitors, CPU holders, keyboard trays, camera mounts, additional shelves, scanner and speaker holders and more. Built-in wire management keeps everything neat and tidy. A product that will meet your needs because you "design it".

Laptop Carts

Our multi-functional and highly adaptable laptop carts feature *pneumatic* height adjustments, offer a compact look and are ideal for use in any space limited location. The carts **LPC700** and **LPC750** have specially designed star-shaped bases with 3-inch wheels to deliver smooth and fluid mobility while maintaining its overall stability.

An additional base weight in the **LPC200** increases stability of the cart. Optional Hot Swappable Power Supply provides uninterrupted power to your workstation wherever and whenever you need it. For this cart we offer multiple color combinations for easy identification and to match the surrounding decor (see laminate color option on page 7).

A. Laptop Cart™ LPC700

- Pneumatic height adjustment
- All-metal body for easy cleaning and disinfecting
- Lockable laptop cover
- Retractable keyboard tray with sliding mouse tray
- Power strip with retractable cord
- 22" star-shaped base
- 3" wheels (two are locking)



B. Laptop Cart™ LPC750

- Pneumatic height adjustment
- Major contact surfaces are made of HDPE (see inside back cover for more information) for "clean rooms" use
- Lockable laptop cover using tamper proof screws
- Retractable keyboard tray with sliding mouse tray
- Height adjustable brick holder with cutout at the ends
- Storage bin
- Wire Basket # WB-100
- 22" star-shaped base
- 3" wheels (two are locking)



C. Laptop Cart # LPC200

- Pneumatic height adjustment
- Laminate/phenolic/HDPE work surface
- Laptop lock shelf with handle
- Right and left sliding mouse tray
- Hot swappable power supply
- Footprint: 24" diameter five-prong base
- Five 4" twin casters (two are locking)



Tablet Carts

At AFC Industries we are committed to creating end-user solutions driven by new technologies. The latest advancements in data access mobility point to the handheld tablet as an increasing popular device. Far more flexible and bedside-friendly than even small laptops, these handheld devices promote safer, better, and faster care by enabling doctors and other caregivers to educate and involve their patients in the process.

The AFC Tablet Carts **TBC150-201** and **LPC 300** were specifically created to hold a tablet or iPad™. You will appreciate this carts' height adjustments, its stability and ease of movement, the small footprint and more.

A. Tablet Cart # LPC300

- Pneumatic height adjustment
- Tablet holder on Z-arm # AFCZ566
- Metal enclosure
- 18"W x 25"D phenolic work surface with handle
- Height of work surface ranges from the floor: 31" to 47"
- Right and left sliding mouse tray
- Wire basket # WB-100
- Footprint: 24" diameter five-prong base
- Additional base weight for increased stability
- Five 4" twin casters (two are locking)



B. Tablet Cart # TBC150-201

- Height of work surface ranges from the floor: 34" to 52"
- 12.5"W x 13.5"D HDPE work surface with handle
- Docking station holder with security screws
- Tablet holder with security screws and tether cable
- Brick holder and cable wrap
- Footprint: 19" aluminum square base
- Additional base weight for increased stability
- Four 4" twin casters (two are locking)



Telescopic Cart™

The **Telescopic Cart™** is designed to accommodate tight spaces. The work surface is **electronically** height-adjustable to enhance comfort and ease of use, whether the operator is seated or standing. Mobile on stable locking casters, the strong, durable **Telescopic Cart™** can be stationed wherever needed and makes adding an extra workstation easy and affordable. Available in different width and depth combinations, the cart can accommodate up to two flat panel monitors.

All sizes are customizable with grommet-mount or clamp-style monitor arms, multiple laminate finishes and colors, keyboard arms and trays, and larger casters for two additional inches of height.

Features and Benefits

- Cold-rolled 11-gauge steel frame with epoxy-powder-coated finish
- Particle-board-core top with your choice of high-pressure laminate finish
- Chemical-resistant phenolic top and bottom surfaces available
- Work surface is electronically height-adjustable with optional electronic tilt
- Multiple colors available (for standard colors, see page 35)
- Four four-inch casters (the front two are locking)
- Additional accessories available

Specifications

- Width: 24", 30", 36"
- Depth: 24", 30", 36"
- Height of work surface from the floor: 30" to 46"

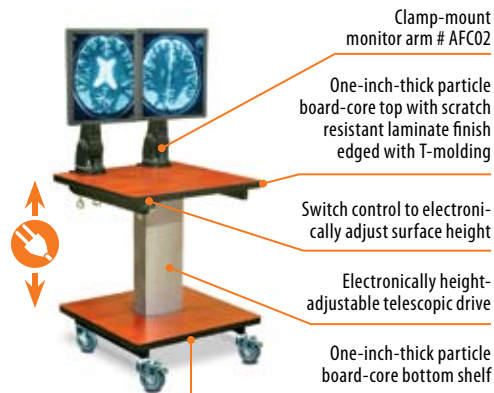
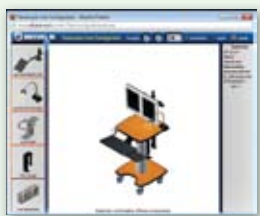

A. Telescopic Cart™
24"W x 24"D

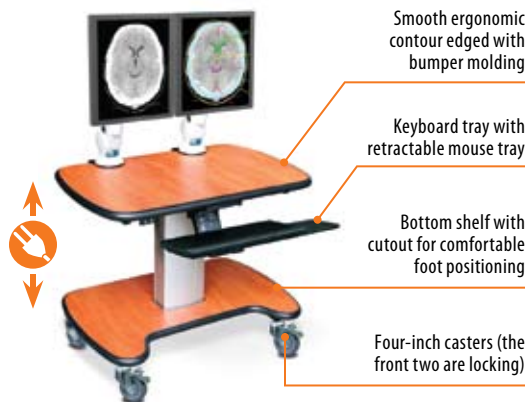

B. Telescopic Cart™
36"W x 24"D

Configure your own **Telescopic Cart™** with our **INTERACTIVE BUILDER** at www.afcindustries.com/telescopiccart



12.2" vertical travel of the **Swinglift Keyboard Arm** allows use of keyboard and mouse while seated or standing up

Work Surface Shapes¹

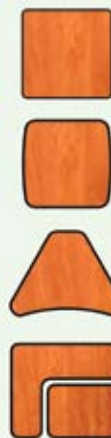

¹ Availability of shape depends on size of the cart



C. Telescopic Cart™

LTC4236-01
42"W x 36"D:

- Grommet-mount Z-arm # AFCZ588-02
- Swinglift Keyboard Arm # KA7001
- CPU Holder # CPU 13-25
- LED Task Light # TAL400

D. Telescopic Cart™

30"W x 24"D:

- Corner work surface shape
- Keyboard Arm # KA6000 and Tray # TR2000 with sliding mouse tray

E. Telescopic Cart™

30"W x 30"D:

- Chemical-resistant phenolic work surface and bottom shelf
- Grommet-mount twin Monitor Arm # AFCPOLE2MH-1

F. Telescopic Cart™

24"W x 24"D:

- Clamp-mount Monitor Arm # AFCPOLE
- Retractable Keyboard Tray # KB01
- CPU Holder
- Wire Basket # WB-100
- Wire Manager # WMF100
- CPU Holder # CPU-99



Mounting solutions make the most of limited-space and decentralize data access

High traffic areas. Tight places. Operating rooms and emergency rooms. Inside and outside patient rooms. These are just some of the areas that are perfectly suited for AFC's variety of mounting solutions. Height-adjustable versions for seated or standing positions. Adaptable to any user. Making empty wall space productive, while decentralizing the availability of data for a greater return on investment in plant and human capital.



Combo Arms AFC7808 and AFC7810 Series

The **AFC7808** and **AFC7810 Series** offer height-adjustable, low-profile, user-friendly solutions for access to electronic records where space is at a premium. The wall mount accommodates most operators in sit-to-stand positions. When not in use, it folds up neatly to the wall, tucked away and unobtrusive.

The flexible **AFC7808** and **AFC7810 Series** are designed with the ergonomic intelligence, strength, durability, and thorough disinfection properties like other AFC products, while offering an easy-to-operate tool for boosting productivity. They are pneumatically height-adjustable within a 12-inch range, and can be locked in any position you chose. Full range of swivel motion at each joint comfortably accommodates different positions and applications, such as sharing information with patients and other professionals in proximity.

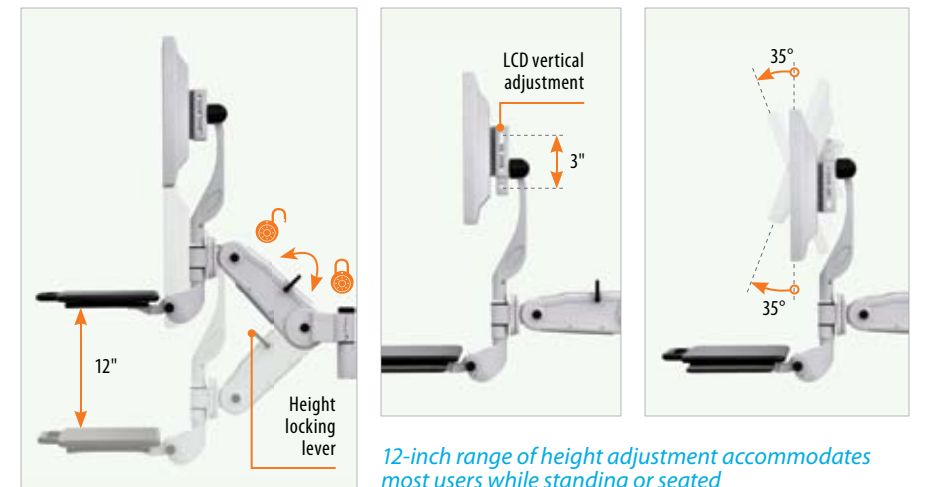
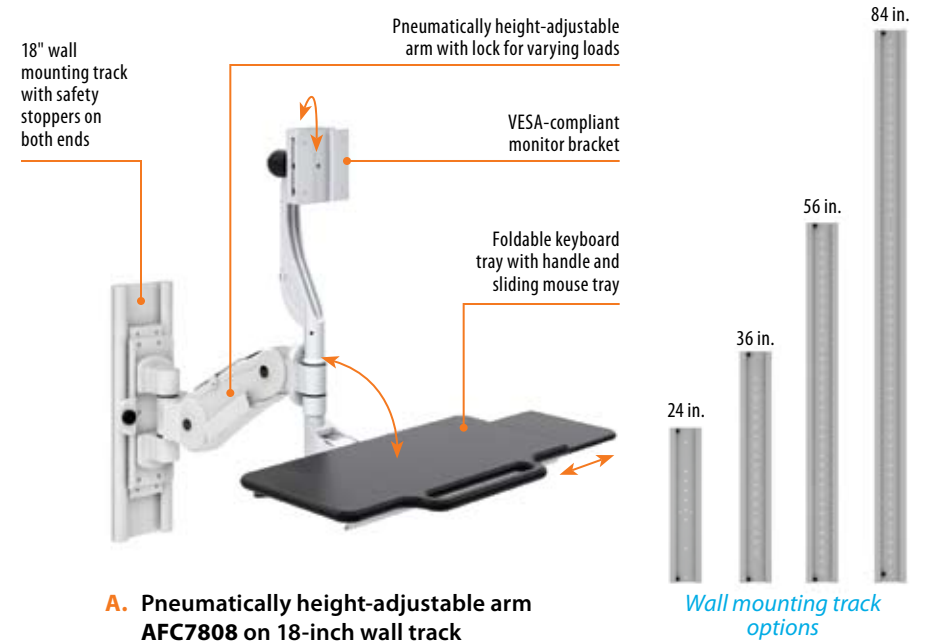

Features and Benefits

- Light-weight aluminum construction for easy operation
- Anti-microbial coatings for thorough disinfection for safe use throughout medical facilities
- Sit-to-stand work positions
- Height locking mechanism at any position for safety, stability, and varying loads
- Full range of swivel motion at each joint
- Keyboard folds for low profile and has a safety lock
- 12-inch range of height adjustment for accommodation of most users
- 34" fully extended from the wall
- 8.5" when retracted and folded to the wall
- VESA 75/100 compliant monitor bracket with horizontal and vertical tilt and 3-inch range of height adjustment
- Mouse holder is included
- Integrated wire management
- Standard color: Gray (call for custom colors)
- Can be mounted directly on a wall or desk
- Option of supplemental 12" or 20" extension arm
- Arm vertically adjusts on 18"; 24" or 36" wall track (wall track is optional)

Keyboard tray with integrated handle easily folds up, saving space when not in use

Mouse tray slides to accommodate left- and right-handed users

With the keyboard folded up, total system depth is as little as about 8.5"

Clean, concealed and neat routing of cables through the cable management system

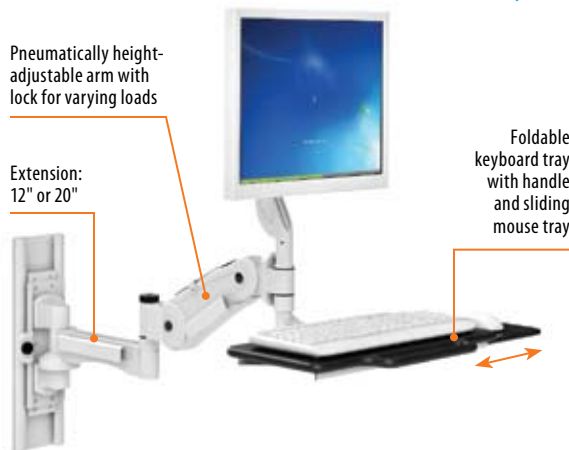
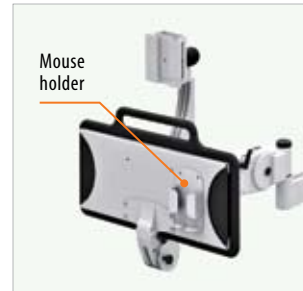
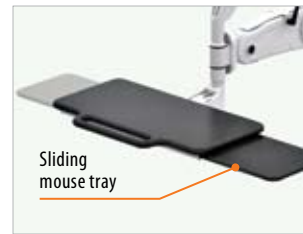
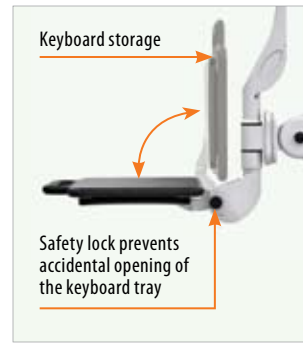

B. Combo arm AFC7808 with 12-inch extension on 18-inch wall track

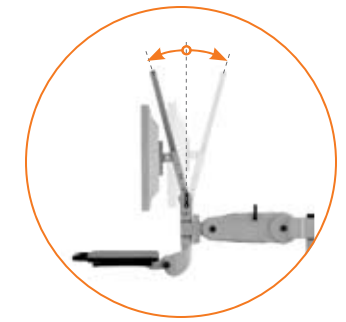
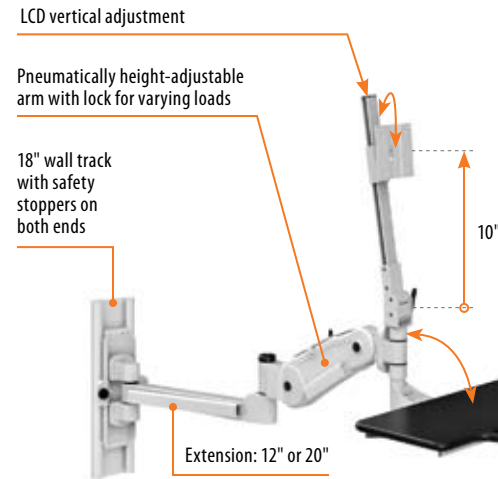

C. Combo arm AFC7810 with 20-inch extension on 18-inch wall track

Mounting Options



Vertical mounting



Horizontal mounting



Desktop mounting

More Mounting Solutions with AFC7808 Series



Monitor arm



Keyboard arm



Laptop arm

Wall Mounts

AFC **Wall Mounts** are perfect for high-traffic areas because of their compact design. This space-saving solution is also ideal for areas where multiple operators use a single computer workstation.

Our monitor and keyboard wall mounts enable you to adjust both the keyboard and monitor height from a seated to standing position, as well as from left to right.

Features and Benefits

- All components are individually adjustable in increments of 2"
- Safety stoppers at both ends
- Spring-loaded locking mechanism for simple and easy height adjustment
- VESA-compliant monitor holder that can be adjusted from portrait to landscape view and tilted to avoid glare
- Foldable and retractable keyboard arm and mouse tray
- Adjustable CPU holder (3 1/2"– 8 1/2"W, 13"– 25"H)

Optional

- Horizontal or vertical positioning
- Double monitor holder on single track (see "Optional Monitor Arms for Wall Mount")
- Horizontal track for multiple monitors
- UPS holder, mouse holder, and other accessories (see page 32)

Standard Colors

- Putty
- Black
- Gray
- White



Configure your own **Wall Mount** with our **INTERACTIVE BUILDER** at www.afcindustries.com/wallmount

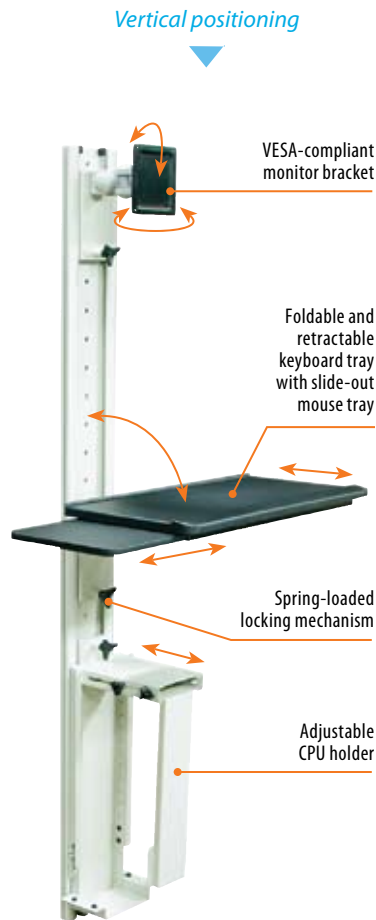

Wall mount for multiple monitors on horizontal track

Optional Monitor Arms for Wall Mounts



Monitor arm # AFCZ5-00



Z-series monitor arm for one monitor

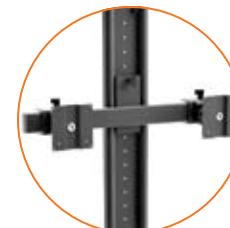

Twin monitor arm # 2MH

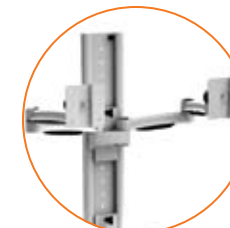

Z-series monitor arm for two monitors



A. Wall Mount # WM36-NH-1F-1KS-C101



B. Wall Mount # WM56-2FZ-KB82R-U-C13_25



C. Wall Mount # WM56-1F-KBZ-Sh-C101

i-Center™

The space-saving **i-Center™** is an attractive wall-mounted workstation that enables computer access wherever needed, without utilizing floor space.

The **i-Center™** includes a fold-down keyboard tray with a damper for smooth operation and a VESA-compliant monitor holder. It accommodates any standard computer and turns empty wall space into a handy work area. The **i-Center™** features all metal or laminated front and side walls that can be specified to match room décor, and mounts easily with grommet holes to allow cabling.

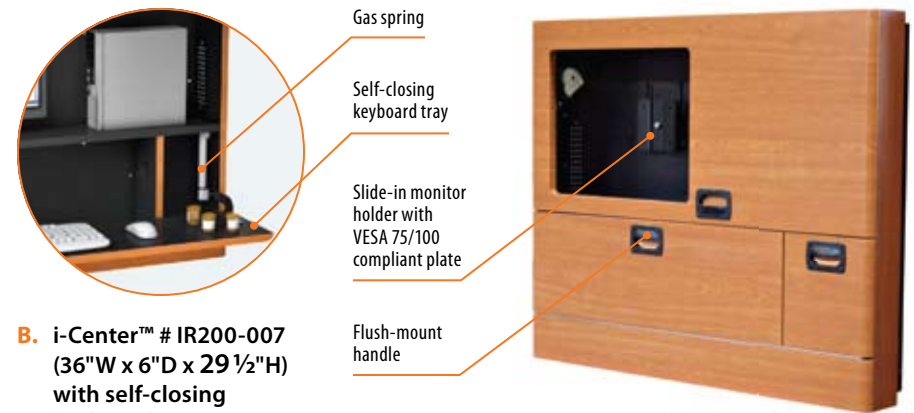

B. i-Center™ # IR200-007 (36"W x 6"D x 29½"H) with self-closing keyboard tray, compartment for CPU and storage

Features and Benefits

- Removable front panel with optional security screws and lock for keyboard shelf to prevent theft
- Fold-down keyboard tray with damper for smooth operation
- VESA-compliant monitor holder
- Grommet holes for cabling
- All metal or laminated front and side walls can coordinate with room décor
- Multiple colors available (for standard colors, see page 35)
- Custom sizes available

Specifications

- Width: 21 ⅛"– 40"
- Height: 19½"– 50"
- Depth: 3"– 9"

Optional

- Self-closing keyboard tray
- Electronic lock
- Optional accessories include: CPU enclosure, mouse holder, scanner holder, cable management, power strips, and fan

Brand new *electronic height adjustable model!*

At the touch of a finger, your staff can ergonomically adjust this workstation to their comfortable setting.



A. i-Center™ # IR900-101 (25"W x 5"D x 43"H) with electronic height adjustment and self-closing keyboard tray



C. i-Center™ # IR600 (25"W x 4"D x 19½"H) for laptop with keyless lock



D. Metallic i-Center™ # IR850-002 (26"W x 4"D x 26"H)

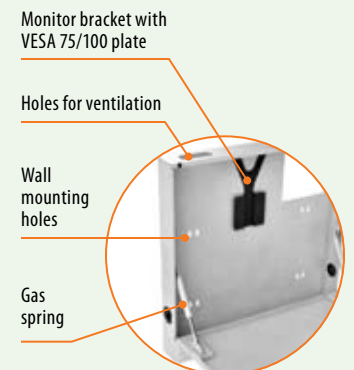



Video Wall

The **Video Wall** consists of one or more tracks for sliding the monitor arms from left to right, where every single arm allows tilting up-down and left-right, as well as micro-adjustment to eliminate gaps between monitors. Z-arms give each monitor an ample range of motion, allowing you to position them in several different viewing arrangements.

Features and Benefits

- Aluminum track with mounting holes and safety stopper at both ends allows monitor holders to slide
- Horizontal or vertical mounting of tracks
- Z-arm monitor holders with extension, tilt, and pan motion; arms have varying length to provide parabolic shape for optimum viewing
- VESA-compliant monitor holder that can be adjusted from portrait to landscape views and tilted to avoid glare
- Combination setup allows horizontal and vertical adjustment of the monitors
- Monitor extends from 4" to 20" from the wall

Optional

- Monitor holders # AFCZ5-00, # AFCZ540, # AFCZ560, # AFCZ580 (tilt and pan only)
- Non VESA-compliant monitor holders available for larger flat screens

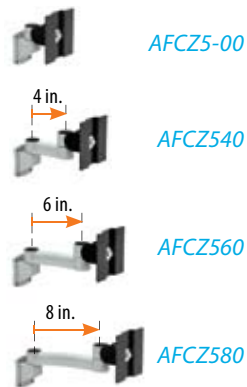

Four-row Video Wall for 24 monitors

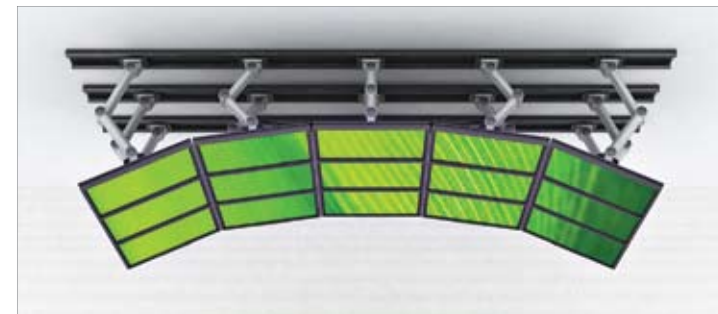
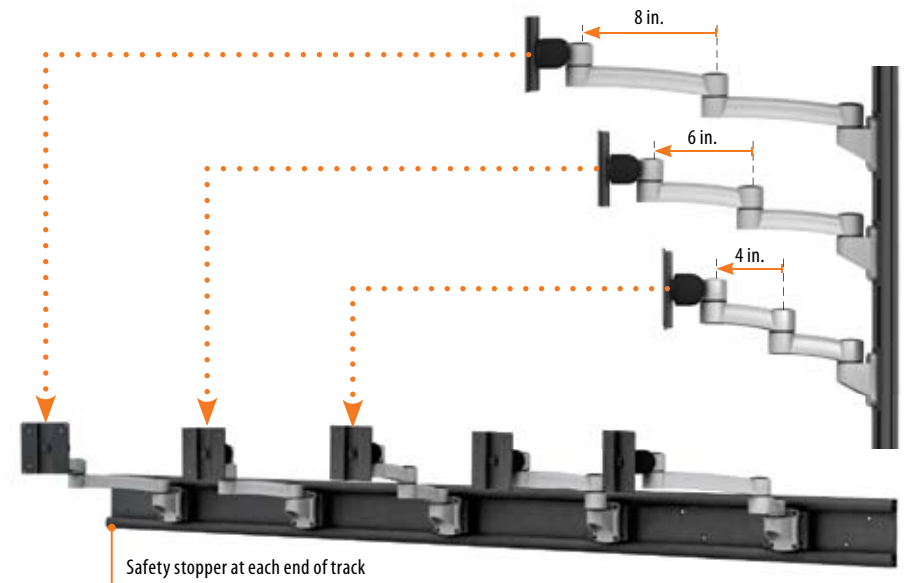

The outer monitor arms are longer than at the center, which lets you create a comfortable viewing arc. When laid out straight, the monitors can get as close as 4" to the wall.

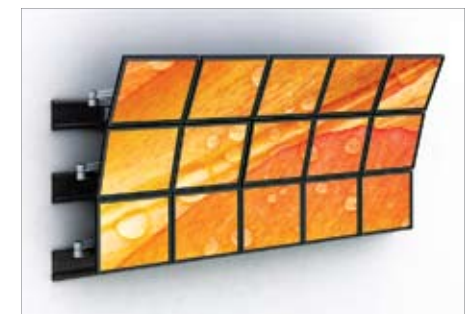

The Video Wall's freedom of motion allows you to combine monitors of different shapes and sizes, in any arrangement, without gaps.



Floor Post™

The **Floor Post Series™** creates a more effective, comfortable, and productive work environment. Based on your specifications, you can have unlimited configurations for any task. Its space saving design also allows multi-side (front/back/side) user capability.

The **Floor Post Series™** can be mounted to various floor surfaces. Monitor, keyboard arms, CPU holders, shelves and other accessories can be made height adjustable on a secure track making this unit suitable for multi-users.

Features and Benefits

- All components are individually adjustable
- Spring-loaded locking mechanism for simple and easy height adjustment (depending on item)
- Built-in wire management
- Monitor holders of your choice: AFC10E/F/G, AFCZ5-00, AFC7808M_01 (see page 31)
- CPU holders of your choice: CPU-101, CPU13-25, CPU-09, CPU-919, or CPU-CS909 (see page 32)

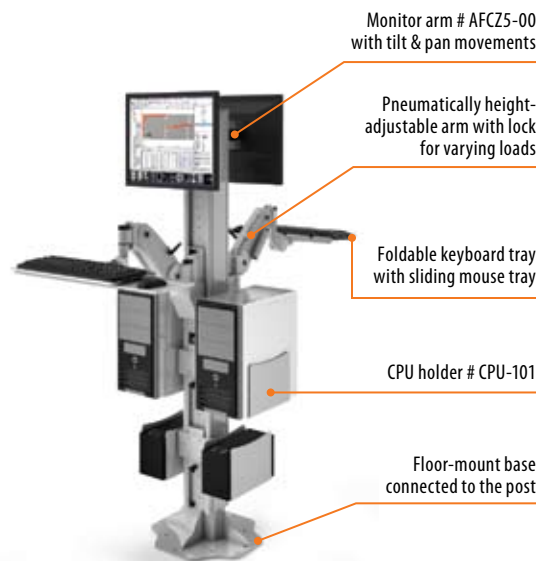

Specifications

- Base footprint: 16"W x 16"D
- Overall height from the floor can be customized to meet your specifications

Optional

- Double-monitor holder
- Foldable and retractable keyboard arm with sliding mouse tray
- Additional shelves and other accessories
- Camera holder

Available Colors

- Putty
- Gray
- Black
- White



A. Floor Post™

- 60"H track
- Height-adjustable camera holder
- Monitor Arms # AFCZ5-00
- 24"W x 16"D work surface
- 18"W x 10"D retractable keyboard tray
- CPU holder # CPU-101
- Wire basket # WB-100
- Floor-mount base



B. Floor Post™

- Two 50"H tracks
- Pneumatically height-adjustable Monitor Arm # AFC7808M_01
- Monitor Arm # AFCZ5-00
- Metal shelf
- CPU holder # CPU-101
- Wire basket # WB-100
- Floor-mount base

We also offer a Pole Station™ with a round metal base that is fixed to the floor



C. Pole Station™

- Gray epoxy-powder-coated finish pole with built-in cutout for wire management
- Height of pole from the floor: 64"
- Z-series Monitor Arm # AFCZ588-01
- Z-series Keyboard Arm with sliding mouse tray # ZKB-P
- Pole-mount CPU holder # CPU-101r
- Floor-mounted 16" diameter metal base (has to be bolted)



Racking Systems enhance and organize your workspace

AFC understands the need to implement ergonomics in all work environments, which is why our racking systems are designed and manufactured to fit the end users. On-staff engineers can customize racking systems to meet your specific requirements.

The **SmartRack™** is a modular space-saving solution that accommodates a variety of technical equipment. Highly versatile, it comes in multiple configurations for mounting LCDs, CRTs, CPUs, and all standard 19-inch rack-mount equipment.

Features and Benefits

- Cold-rolled 11-gauge steel frame with epoxy-powder-coated finish
- Particle-board-core top with your choice of high-pressure laminate finish
- Customized work surfaces available edged with T-molding/bumper molding
- Work surface and shelves are height-adjustable in one-inch increments
- Customized metal or wood shelves, fully adjustable and tiltable
- Multiple colors available (for standard colors, see page 35)
- Built-in wire-management conduits
- Glides and additional accessories available

Specifications

- Width of frame: 24", 30", 36"
- Depth: 24", 30", 36"
- Height of frame: 36", 48", 60", 73", 83"
- Two-inch casters (the front are locking)



Configure your own **SmartRack™** with our **INTERACTIVE BUILDER** at www.afcindustries.com/smartrack

SmartRack™ Basic Components

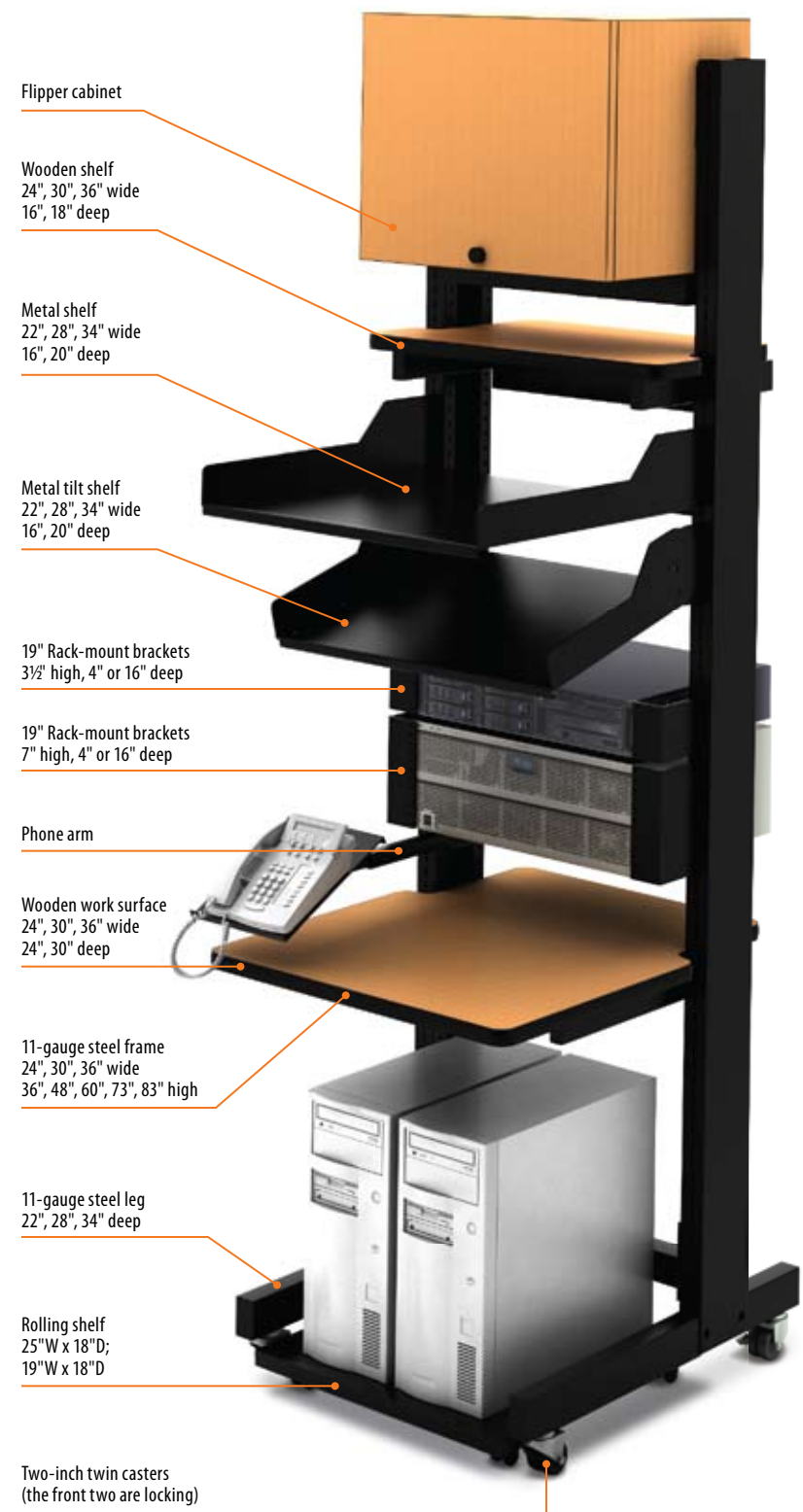



Interactive workstations. Flexible. Adjustable. Adapt to you!

Different users. Different needs. AFC workstations are *electronically* height-adjustable at the touch of a button. Independent adjustment of monitor height and focal length for optimal viewing. Digital readouts to preserve and easily return to your ideal settings for surface and monitor placement. Available with surface tilt. A host of valuable features—ambient LED backlighting to ease eye strain and improve reading quality; a variety of monitor platforms; mounting solutions for the growing interest in large monitors; acoustical privacy partition to improve concentration; pop-up data port and built-in USB hub to facilitate neat and tidy use of ancillary equipment. And more.

Our flexible workstations and carts come in a wide variety of sizes, shapes, multi-tiered designs, and color options that accommodate virtually any location and workplace need. They can be enhanced with cabinetry, shelving, computer storage, and retractable features.

Features and Benefits

- Electronic height adjustment of work surface
- Monitor arms with horizontal, vertical, and tilt adjustment
- Complete wall-to-wall installation services
- Cold-rolled 11-gauge steel frame with epoxy-powder-coated finish
- Particle-board core top with your choice of high-pressure laminate finish edged with bumper molding
- Multiple color available (for standard colors, see page 35)

Optional

- Electronic adjustment of monitor height and focal length
- Advanced warm/cool air environmental control system regulated at the workstation
- Pop-up data ports and a built-in USB hub embedded in the work surface
- Light and sound barrier partitions
- Partitions with removable lower metal panel for back CPU access and continuous cable management
- Mobile CPU enclosure



**A. The Whitestone™ Desk
84"W x 40"D:**

- Electronic adjustment of work surface height and tilt
- Electronically height adjustable and retractable monitor platform on telescopic drives for five monitors # AFCERGO05
- Adjustable Phone Arm # TA002
- Pop-up data port & USB hub
- Acoustical partition
- Cup Holder # MCH-100
- Two adjustable CPU Holder # CPU-07
- Two split bottom shelves
- Four 4" casters #CAS-4

**B. Ergo Tier™ SW Desk
60"W x 30"D:**

- Independent electronic height adjustment of work surface and monitor platform
- 10"-high slatwall on telescopic drives
- Two Z-series Monitor Arms #AFCZ666-01
- Two Z-series Monitor Arms #AFCZ566-01 on 20" extrusion
- Pop-up data port & USB hub
- Two desk-mount CPU holders # CPU-01
- Four 4" casters #CAS-4

**C. Half-Moon Dual Tier™ Desk
93"W x 46"D:**

- Independent electronic height adjustment of both tiers
- Z-series Arms for one and two LCD monitors # AFCZ500-01 and # AFCZ500-02
- Adjustable Dictation Arm # TA003B
- Tree split bottom shelves
- Glides # GLID-ADJ

**D. Single Tier™ Desk
60"W x 36"D:**

- Electronic height adjustment of work surface
- Three Z-series Monitor Arms # AFCZ566-01 on 56" track on three poles
- Swinglift Keyboard Arm #KA7001
- Full bottom shelf with Foot Rest #FR010
- Four 4" casters #CAS-4



Accessories help to optimize ergonomics in your workspace

AFC Industries has an entire division devoted exclusively to designing accessories for every conceivable requirement.

From ergonomically correct and functionally optimal monitor mounts to keyboard trays with retractable features; from ambient and task lighting solutions for different needs and applications to cable management; from attachments for holding a telephone and/or dictation equipment to a beverage cup, and much more.

Visit www.afcindustries.com/accessories to learn about our wide array of accessories for a multitude of needs.

LCD Monitor Arms/holders

Desktop Series

Grommet-mount AFC01	Clamp-mount AFC02	Clamp-mount AFCPOLE	Clamp-mount AFCPOLE2MV-1	Clamp-mount AFCPOLE2MH-1

Z-Series

AFCZ588-01	AFCZ588-02V	AFCZ588-02	AFCZ588-03
AFCRAILZ03-CLAMP			AFCZ588-04

Wall Mount Series

AFC10E	AFC10F	AFC10G	AFCZ5-00	AFCZ560	AFCZ568	AFC2530
AFCZ568-05-WMH				WM18_AFC7808M_01	AFC3255-01	

CPU Holders

Desk/wall-mount CPU 13-25	Wall-mount CPU-09	Wall-mount CPU-801-WD
Wall-mount CPU-CS909	Wall-mount CPU-919	Wall-mount CPU-16-AFC22
		<i>new!</i>
Wall-mount CPU-101	Mobile CPU Cradle CPU-02	Thin client holder Cradle CPU-601

Lighting

LED Task Light TAL400
AmbiTask Light Combo AMBL001

Cable Management & Power Solutions

Length: 12", 24", 36"		Diameter: 1/2"	
Cable Manager WM201		Cable Wrap WM-400	Retractable Power Cord RPC-101
A - 1 7/8" x 1"H			
B - 7/8" x 1/2"H	Length: 30", 60"		
Cable Manager WM100	Wire Managers WMF100 and WMF200	Portable AC Power System PS-TL-1	Data & Power Ports DPA-01

More Accessories

Keyboard Arm & Tray KA6000 & TR2000	Keyboard Arm & Tray KA6000 & TR3000	Keyboard Arm KA7001	Keyboard Tray KB03	Keyboard Arm & Tray WM-TR-MZ
Antiseptic Wipe Holder AWH100	Biohazard Waste Holder BWH100	Wire Basket WB-100	Cup Holder MCH-100	Mouse Holder M001
Phone Arm TA002	Laptop Arm AFCZ566-01-LWM-01	Air Fan FanR1-100	Ergonomic Foot Rest FR002	Scanner Holder S01

Storage Accessories

30", 36", 48", 60", 72" or 84" wide			
Flipper Cabinet FC	Wood Clipboard Holder CLPHLD-W		
One Door Cabinet D0123	Two Door Cabinet D0124	Mobile Film Box FB-100	Mobile Pedestal P2BF16WD
Metal Pedestal P2FF19MF	Wood Pedestal with lock P3BBF19MF	Slatwall	Printer Shelf/Rolling Shelf EXSHR META

FREE on-site consultation

At AFC we want to get it right the first time, every time, to create a great custom environment for our Customers. That's why we will come to you to ensure we are maximizing your space and that everything is measured up just right. We will work with your team, at no charge to you, from the beginning to the end of your project.

FREE project support

Our team is here to assist you with your vision. We have the experience to help with your project and pride ourselves in going above and beyond to not just meet, but exceed your expectations.

FREE design service

We want to use our many years of experience creating spaces to take full advantage and help you go beyond your imagination. With some of the most mechanically advanced products, we will help you achieve your goals, all at no additional cost to you.

Customization

AFC can easily customize all products to adapt to your professional and individual requirements. Whether you need help choosing the right components to configure a product or are considering a complete room redesign, our staff is committed to offering you assistance every step of the way.

Outstanding customer support

Our experienced sales and engineering teams are here to walk you through the process from the smallest to largest jobs. Building rapport with our customers is a driving force throughout the relationship and is maintained during the entire project including follow-up.



Anti-microbial paint

AFC now offers the added protection of anti-microbial powder-coat finishes on its products to provide protection against a broad spectrum of micro-organisms. When applied to mobile carts, wall mounts, and work stations the risk of spreading harmful bacteria and viruses between patients and health care workers is greatly reduced, according to doctors using the anti-microbial powder coating in their hospitals and laboratories.

High-density polyethylene (HDPE) top now available with antimicrobial protection

A new kind of antimicrobial protection upgrade now available in many of AFC's polymer sheets, slabs and massive shapes. HDPE helps products stay cleaner between cleanings and inhibits the growth of product-damaging microorganisms, including bacteria, algae and fungi on the surface. Microbe cell walls that come into contact with HDPE are destroyed on contact, without creating opportunities for adaptive or resistant strains to form. Because the antimicrobial agent is bonded at the atomic level throughout the sheet, it will not leach out of the product. This means the agent retains its effectiveness throughout the life of the product and does not harm the environment.

It is safe, non-toxic and non-hazardous to ship and handle. The product is EPA-registered and listed with the FDA as a modifier to medical devices.

Products made using AFC's polymers with HDPE are easy to clean, disinfect and keep hygienic using standard cleaning procedures. Constant use of cleaning solutions will not affect any polymer.

STANDARD COLORS

Laminate



Black

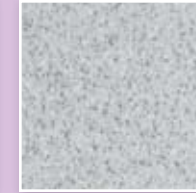

Speckled Gray



Gray



Mahogany



Wild Cherry



Natural Pear

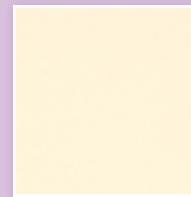

Putty

For any other color call us at 1.800.663.3412

Molding



Black

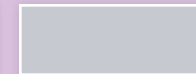

Gray



Putty

Frame



Black

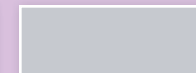

Gray

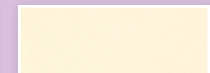

Putty



White

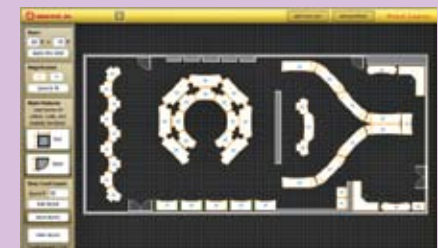

*Use our **Room Layout Designer** to see how you can create an ergonomic environment with AFC's products*

Total Data Access Solutions

Ergonomics throughout your facility



Main Reception



Exam Room



Emergency Room



High-Traffic Area



Intensive Care



In-Patient Floor



Patient Room
EMR



Radiology Reading
Room

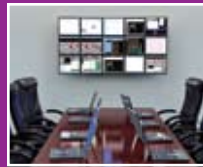

Conference
Room



Hospital Security
Room



13-16 133rd Place • College Point • NY 11356

Toll free: 1.800.663.3412

T: 1.718.747.0237

F: 1.718.747.0726

www.afcindustries.com



Scan here with your
smart phone to visit
our website