

ELECTRONIC MEDICAL RECORDS

Catalog ▶ Issue 19, Vol. 1



MOBILE DATA ACCESS



MOUNTING SOLUTIONS



ACCESSORIES

afc INDUSTRIES, INC.
Solution creators for working environments™

www.afcindustries.com

ERGONOMICS FOR THE DIGITAL WORKPLACE: JUST WHAT THE DOCTOR ORDERED

In recent years, advanced digital technology has helped physicians dramatically enhance patient care, and delivered new efficiencies and cost savings in every medical environment. Today digital diagnostic images can travel around the world for

When pushing the boundaries of digital technology, you better watch your back — wrists, arms and even knees.

consultations and second opinions in far less time than it takes to drive to work and the bits and bytes of computer files are rapidly replacing the scripts and slips of paper

files, as many facilities implement electronic medical records (EMR).

But as your facility continues to push the boundaries of digital technology, if you haven't replaced your outdated desks and chairs with modern ergonomic furniture designed for the digital age, you better watch your back — not to mention your wrists, arms, elbows and knees. Experts agree that the long hours spent in front of computers and the repetitive motion required to utilize most technology day in and day out are a significant source of work related injuries. Moreover, optimizing the interface where man meets machine (aka workstations, carts, racking systems, wall mounts etc.) can go a long way towards maximizing the impact of your advanced technology and creating the comfortable work environment that leads to satisfied and productive staff.

For over a decade, AFC Industries has been a leader in the design and manufacture of ergonomic furniture that helps medical facilities meet these goals. Whether you're outfitting a lab, imaging suite or operating room, whether you're upgrading the ergonomic footprint of an entire facility or just building new functionality into corners or hallways, AFC Industries has the firsthand knowledge and experience to make your project a success. AFC industries understands the demands unique to every job function and workplace in the medical world and the stringent demands of a healthcare environment overall.

As you look through the pages of this catalogue, you'll see plenty of options to meet your needs. But remember, every piece of furniture can be customized to your exact specifications. We'll even provide the furniture consultants and engineers to help you make the right choices, as well as to assist you with overall space design.

You can rest assured that every AFC Industries offering is engineered with quality and value to make the most of your budget. All carts are made of reinforced steel for years of use. Our pressurized, scratch-resistant laminate surfaces are available in a choice of colors. Optional anti-microbial painted finishes will protect against a broad spectrum of micro-organisms in a healthcare environment. All furniture is built to order, comes fully assembled and is built for years of service — just what the doctor ordered.





p. 6



p. 15



p. 25



p. 18



p. 28

Contents

Mobile Data Access 4

PC (Point-of-Care) Cart™	5
Laptop & Tablet Carts	14
Plasma Cart™	18
Pole Cart™	20

Mounting Solutions 24

i-Center™	25
Wall Mounts	27
Floor Post	33

Accessories 34

LCD Monitor Arms/Holders	34
Laptop Arms. Phone/Dictation Arms	37
CPU Holders	37
Keyboard, Mouse, and other Accessories	37
Cable Management and Power Solutions	38
Glides & Casters	38

Complimentary Services 38

Standard Color 39

Specifications in this catalog are subject to change without notice. Actual design may vary. The illustrations and pictures shown in this catalog are for presentation purposes only.

ICON KEY



Electronic adjustment



Pneumatic adjustment



Manual adjustment



Adjustment with tools

MOBILE DATA ACCESS



Optimizing your mobile computing needs

Today's advancing technological world demands what we at AFC refer to as "Whenever ⇔ Wherever" access to data, including electronic medical records, radiology images, and more. The need has become ubiquitous, throughout all areas of healthcare facilities and professional functions — from radiology reading rooms to patient bedsides, operating rooms, conference rooms, and more; in oncology, cardiology, nuclear medicine, labor and delivery, and more.

AFC's array of durable mobile carts are designed to meet this growing need, while incorporating ergonomic features that make them adaptable to any user. Security features protect both sensitive patient information and computer equipment. Our carts are built from materials for thorough disinfection. They are available in footprints as small as 19" for easy maneuvering in tight places. Long-lasting batteries can be loaded so that carts can move from area to area without being connected to electrical outlets.

Now available on all PC (Point-of-Care), Laptop, Tablet, and Pole carts, our new **Hot Swappable Power Supply** provides uninterrupted power to your workstation wherever, and whenever you need it.

Whatever your need is, AFC can build a mobile cart solution for you.

PC Cart™



The PC (Point-of-Care) Carts™ designed for maximum flexibility and streamlined movement. They combine enhanced functionality with the hallmark durability and ergonomic design of AFC's mobile work stations. Our PC Carts™ enables physicians to bring advanced computer technology to the bedside, operating room and any other location where patients will benefit from today's medical computer applications.

The PC Carts™ feature a low profile, small footprint, pneumatic (optional electronic) height adjustment, and support all-in-one computer as well as separate thin client and monitor. For maximum portability, the carts can accommodate a battery power source (see page 8 for power supply options). Select from our range of monitor arms, CPU holders, keyboard trays and other accessories to complete your configuration.



PC Cart™ 910



PC Cart™ 900



PC Cart™ 800



PC Cart™ 500

Features and Benefits

- Sit-to-stand height adjustment (pneumatic or electronic)
- Thorough disinfection for clean room use
- Supports all-in-one computer as well as separate thin client and monitor
- Mounting for all-in-one computer or standard monitor VESA (75/100)
- Rounded phenolic, HDPE¹, laminate, or metal work surface
- Seamless integration of handles into the work surface on all four corners for easy grip from any user position
- 5" casters with round tread wheels or 4" twin casters

Optional

- Keyless electronic lock for utility drawer and divider to facilitate administration of care in two-patient rooms
- Phenolic retractable keyboard tray with ergonomic negative and positive tilt and swivel
- Wire manager
- Mouse holder, wire basket, scanner holder, and additional accessories available (see page 34)

¹ High-density polyethylene (see inside back cover for more information)



PC Cart™ 910 (front view)

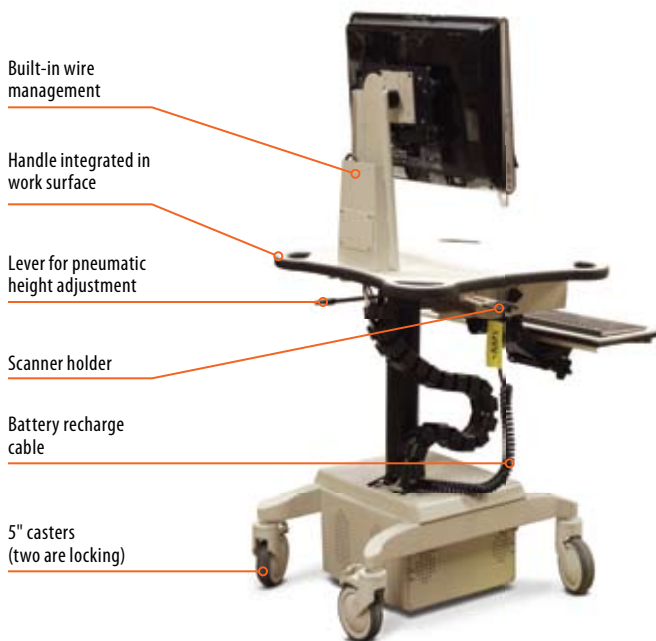

PC Cart™ 910 (back view)

PC Cart™ 910

The PC Cart™ 910 combines a streamlined look and enhanced functionality with the hallmark durability and ergonomic design of AFC's mobile work stations.

With an all-in-one computer, the height-adjustable PC 910 offers a battery that can run for up to 25 hours before recharging. UL 60601-1 compliant, it is safe to use throughout facilities. Fleet management software allows for IT monitoring, management, and programming of carts for location, battery status, and scheduling of computer shutdown, recharging and maintenance.

A phenolic/HDPE work surface with rounded corners enhances safety and appeal. Cutout handles on all corners facilitate grip, access from any user position, and range of motion. The retractable phenolic keyboard tray features ergonomic tilt, swivel, and a sliding mouse tray for both left- and right-handed users.

Specifications

- Pneumatic height adjustment
- Rounded phenolic/HDPE work surface for greater safety, comfort, and appeal
- Seamless integration of handles into the work surface on all four corners for easy grip from any user position
- Keyless electronic lock for utility drawer and divider to facilitate administration of care in two-patient rooms
- Phenolic retractable keyboard tray with ergonomic negative and positive tilt and swivel
- Mouse tray slides to accommodate left- and right-handed users
- 5" casters with round tread wheels for ease of movement
- Footprint size: 20"W x 24"D
- Work surface size: 24"W x 24"D
- Keyboard tray size: 19"W x 8"D
- Height of work surface from the floor: ~30" to 42"

Standard Colors

- Putty
- Gray
- Black



A. PC Cart™ 910 with CPU Holder and Mouse Holder



B. PC Cart™ 910 with camera holder

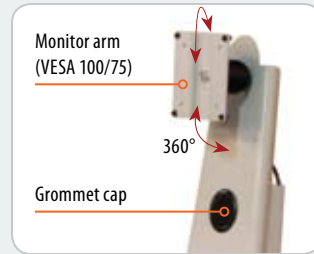

Mounting for all-in-one computer or standard monitor (VESA 100/75)

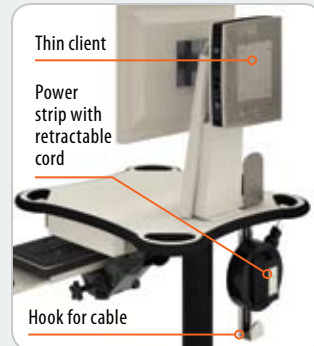

Supports separate thin client and monitor

Carts for telemedicine application



C. Telemedicine Cart TMC300 with camera shelf on Z-arm

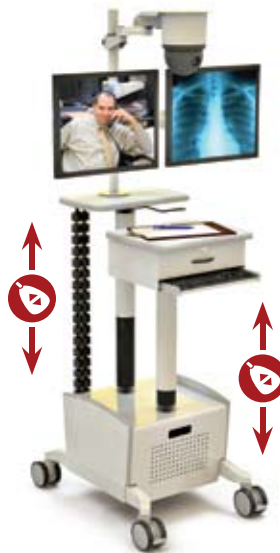

D. Telemedicine Cart XPC1926 with two pneumatically height-adjustable drives and camera shelf on Z-arm



Lever for pneumatic height adjustment



Electronic lock

Utility drawer with keyless electronic lock and divider

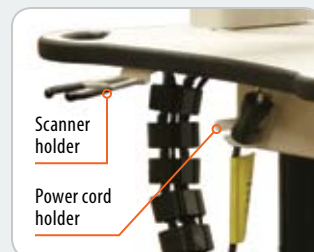

Scanner holder

Power cord holder

POWER SUPPLY OPTIONS

Hot Swappable Mobile Power Systems

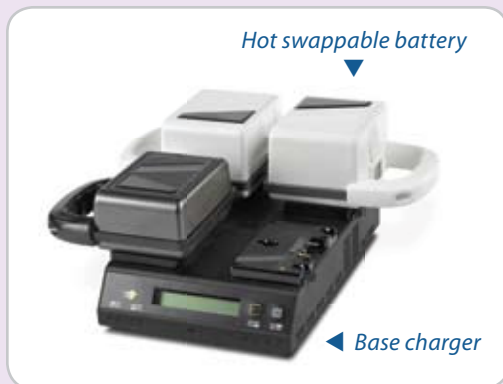

Features and Benefits

- **Cycle-Life:** Replace batteries in YEARS not months
- **Uninterrupted Operation:** Simultaneously powered technology while the batteries charge
- **Fast charging:** Within 2 hours while the technology is in use
- **Lighter:** Significant weight reduction
- **Runtime:** Entire shift or longer
- **Easy access:** Changes and upgrades are easy to complete
- Virtually Maintenance Free

Battery Specifications

- **Size:** 3.75" x 5.25" x 4"
(9.53 cm x 13.34 cm x 10.16 cm)
- **Weight:** 3.4 lbs (1.5 kg)
- 14.4 V 160 Wh Li-Ion battery
- Military grade cell technology
- Integral digital features
- REAL-TIME display
- Meets regulatory requirements including CE

How it works:

Two of the batteries are mounted to the cart while two others are being charged. Once the two on the cart are depleted, the user swaps them out for fresh ones.

Runtime:

The cart would have about 360 Wh of available power. Once you calculate your wattage draw, divide the number by available power to get your runtime.

Charging:

Typical charge time is 3.5 hours to 85% and 4 hours to 100%.

LiFe (Lithium Iron Battery)

Features and Benefits

- UL 60601-1 compliant for safe use in all patient and non-patient areas
- Power alert software protects data and low-battery alarm can be muted
- IT Fleet management software for monitoring, programming, and management of PC 910s throughout a facility
- LED monitoring of battery status
- Advanced 3-stage charger accelerates recharging and increases safety
- Internal Automatic Transfer Switch allows power supply to run connected equipment while battery module is recharging

Sealed Lead Acid Battery

We offer a **Power Supply Unit** with three main components:

Power Supply/Recharger (remains the same for any size battery) recharges the battery that it is connected to. The cart has three AC power outlets to which the user can plug in their monitor and CPU.

LED-Battery-Status Display

shows amount of power in battery, alerting user to recharge battery by connecting to Power Supply/Recharger. The unit is generally attached to the monitor arm or in a visible location of the cart.

Battery available in three sizes, each determines run time (~4.3 hours, ~6.5 hours, and ~10 hours).

PC Cart™ 900

For high-traffic areas where the width and height of the base are crucial, especially between patient beds or medical equipment, AFC offers the **PC Cart™ 900**.

Available with an optional scanner holder and additional accessories, the **PC Cart™ 900** can easily adapt to all work situations. It's sleek, yet durable, quad-point base has a small footprint and an overall height of less than 6" from the floor.

Specifications

- Pneumatic height adjustment
- Rounded phenolic/HDPE work surface
- Seamless integration of handles into the work surface on all four corners for easy grip from any user position
- Mouse tray slides to accommodate left- and right-handed users
- Work surface size: 24"W x 24"D
- Keyboard tray size: 19"W x 8"D
- Footprint size: 18"W x 18"D
- 4" twin casters
- Height of work surface from the floor: ~30" to 42"

Available Colors



PC Cart™ 800

This multi-purpose and functional cart is ideal for all business and service sectors. The **PC Cart™ 800** has laminate, phenolic, or HDPE work surface and a rectangular base of 19"W x 20"D.

Select from our range of monitor arms, CPU holders, keyboard trays and other accessories to complete your configuration (see page 34).

Specifications

- Laminate/phenolic/HDPE work surface with handles
- Work surface size: 22 ½"W x 20"D
- Footprint size: 19"W x 20"D
- 4" twin casters
- Height of work surface from the floor: ~30" to 42"

Available Colors

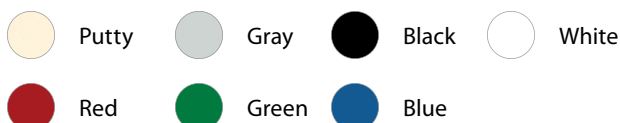

E. PC Cart™ 900 with CPU Holder # CPU-99 and Mouse Holder

F. PC Cart™ 900 with drawer, Mouse Holder, and Scanner Holder

Optional

- Keyless electronic lock for utility drawer and divider to facilitate administration of care in two-patient rooms
- Phenolic retractable keyboard tray with ergonomic negative and positive tilt and swivel
- CPU holder, mouse and scanner holders, and additional accessories available (see page 34)



PC Cart™ 800 with clamp-mount monitor arm # AFCZ588-01

G. PC Cart™ 800

- Laminate work surface
- Pole-mount Monitor Arms # AFCZ5-00
- Retractable keyboard tray # KB03
- Lockable CPU holder # CPU-09
- Handle



H. PC Cart™ 800

- HDPE work surface with two built-in handles
- Pole-mount Monitor Arms # AFCZ5-00
- Retractable keyboard tray # KB03
- Base-mount CPU holder # CPU-99



The low profile of the PC Cart™ 500 gets you closer to the patient's bedside

PC Cart™ 500

The PC Cart™ 500 is pneumatically height-adjustable to enable computer use while the user is standing or seated. The cart's all-metal body enables disinfection and clean-room use. Our PC Cart™ 500 with power supply brings advanced computer technology to any location. A retractable keyboard tray with side-out mouse tray are included.

Specifications

- Pneumatic or electronic height adjustment
- Built exclusively from cold-rolled steel with epoxy-powder-coated finish
- Work surface size: 20"W x 20"D
- Retractable keyboard tray with slide-out mouse tray (19"W x 8 ½"D)
- Rectangular base size: 20 ½"W x 24"D
- 4" casters
- Height of work surface from the floor: ~30" to 42"
- Additional accessories available (see page 34)

Optional

- Power supply unit with LED monitoring of battery status (see page 6)
- CPU/UPS holder
- Wire manager # WMF200 (to manage cables going from the power supply unit to the LED display)

Available Colors

-  Putty
-  Gray
-  Black

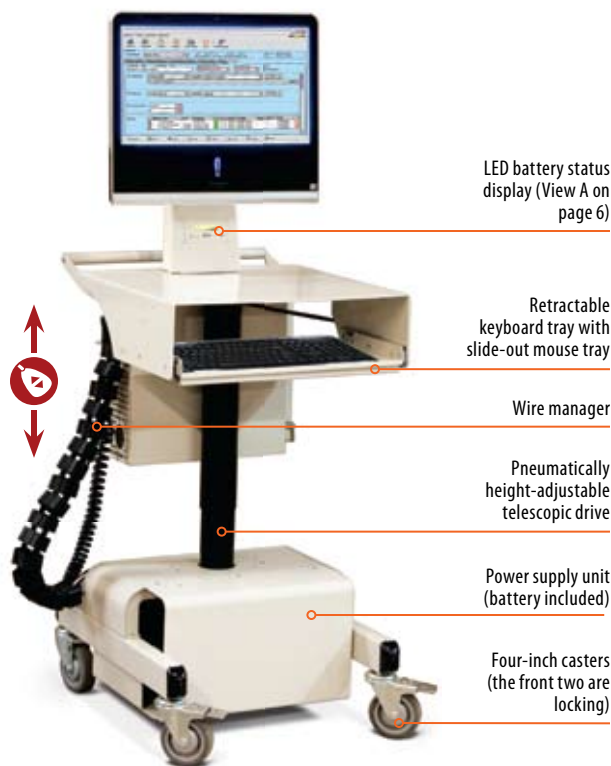

PC Cart™ 500 with power supply

Optional Monitor Arms



Twin Monitor Arm
2MH



Z-series Monitor Arm
AFCZ588-01



Z-series Monitor Arm
AFCPOLE

PC Cart™ Accessories



Antiseptic wipe holder



Biohazard waste holder



Wire basket

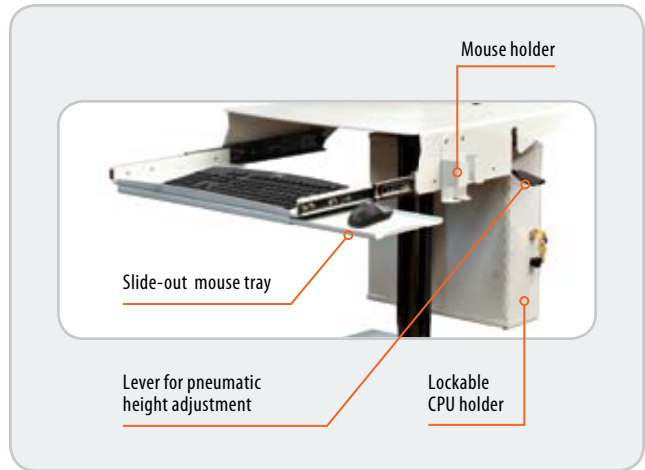

I. PC Cart™ 500

- Twin Monitor Arm # 2MH
- Retractable keyboard tray with slide-out mouse tray
- Mouse holder # M001
- Handle
- Power supply shelf
- Back shelf



J. PC Cart™ 500

- LED battery status display
- Retractable keyboard tray with slide-out mouse tray
- CPU holder # CPU-09
- Handle
- Power supply shelf
- Back shelf



The PC Cart™ 500 also comes in **Dual** and **Deluxe** configurations. The **Dual PC Cart™ 500** allows for independent movement of two surfaces. The upper surface can be used as a laptop platform. The **Deluxe PC Cart™ 500** features electronic height adjustment.

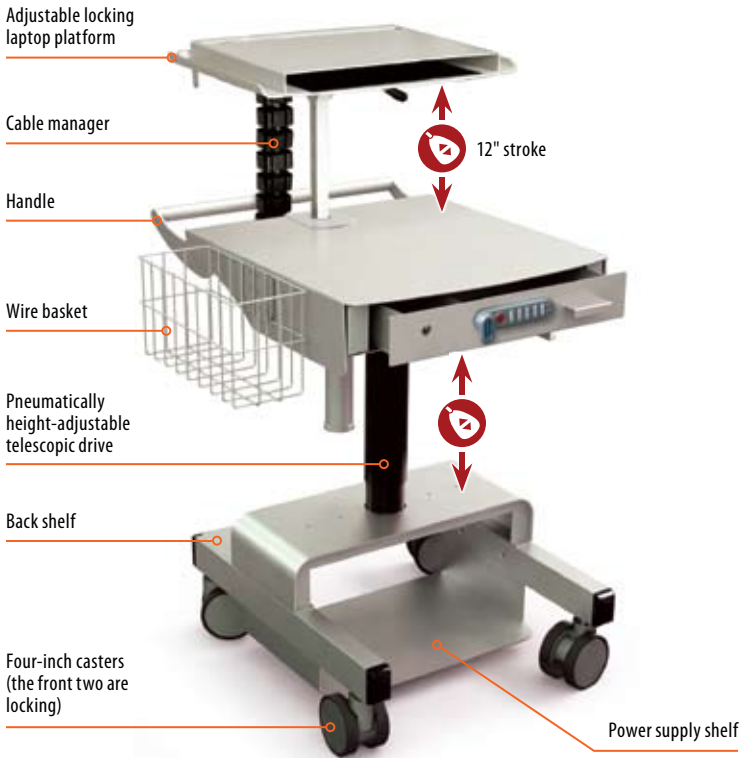

Dual PC Cart™ 500 with utility drawer

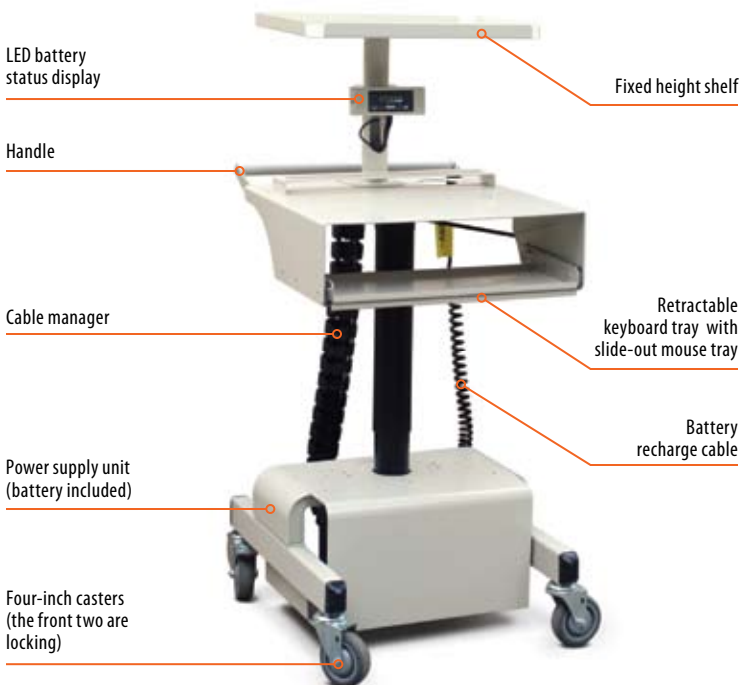
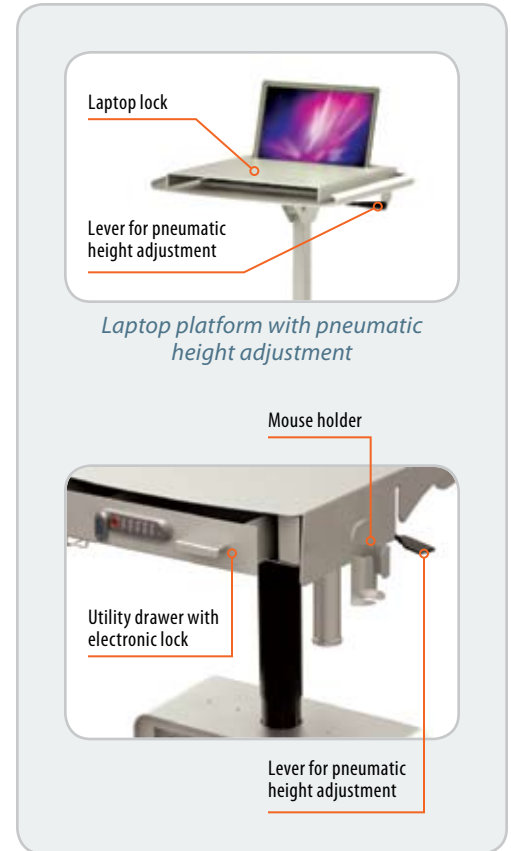

Dual PC Cart™ 500 with power supply

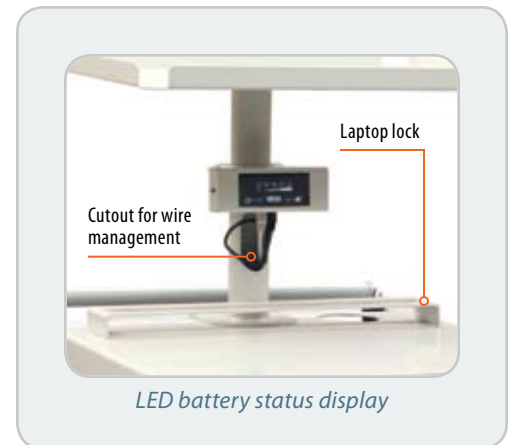



Control switch for vertical adjustment

Electronically height-adjustable telescopic drive

Battery recharge cable

Power supply unit (battery included)

Four-inch casters (the front two are locking)



Electronic Adjustment:

▪ SURFACE HEIGHT

Electronic height adjustment at the touch of a button allows easy shifting between seated and standing positions



Deluxe PC Cart™ 500 with power supply



Standing position

K. Deluxe PC Cart™ 500 for one LCD monitor

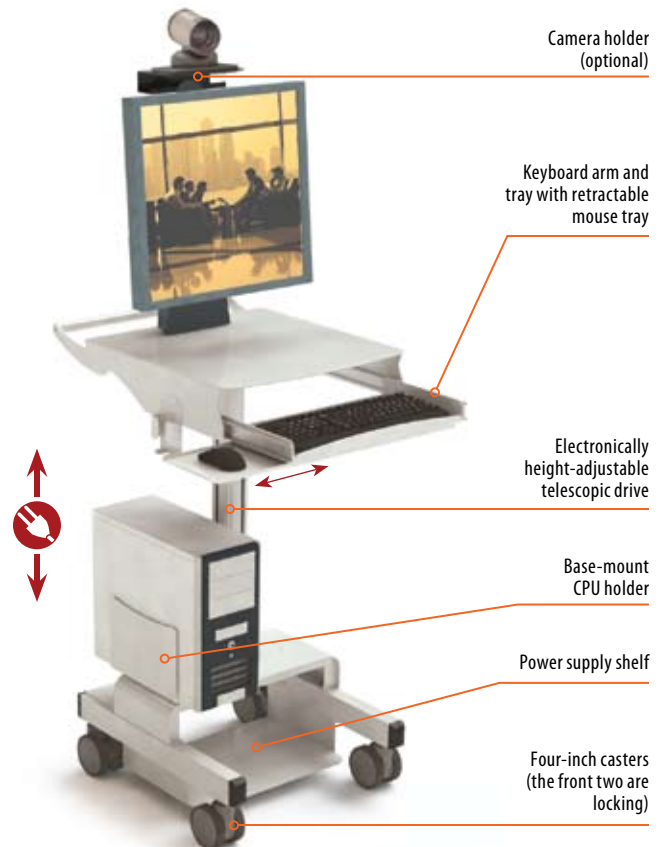

Camera holder (optional)

Keyboard arm and tray with retractable mouse tray

Electronically height-adjustable telescopic drive

Base-mount CPU holder

Power supply shelf

Four-inch casters (the front two are locking)

Deluxe PC Cart™ 500



Seated position

L. Deluxe PC Cart™ 500 for two LCD monitors

Laptop and Tablet Carts



Laptop Cart # LPC700 with laptop lock

Laptop Cart LPC700

The multi-functional and highly adaptable cart **LPC700** designed to hold laptop and ideal for use in any space limited location. This cart offers a compact look, with a footprint of 19" and an overall height of less than 6" making the **LPC700** suitable for small work areas. It's specially designed star-shaped base with 3-inch wheels delivers smooth and fluid mobility.

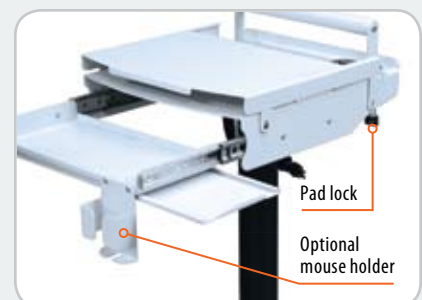
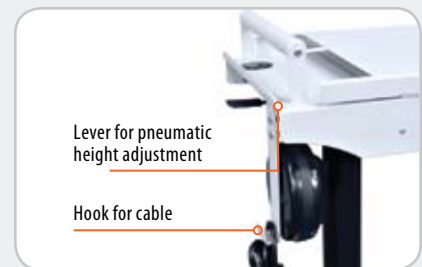

Laptop cover lifts and locks with the pad lock

Features and Benefits

- All-metal body enables disinfections and clean-room use
- Built exclusively from cold-rolled steel with epoxy-powder-coated finish
- Pneumatic height adjustment
- Retractable keyboard tray with slide-out mouse tray
- Additional accessories available (see page 34)

Available Colors

- Putty
- Gray
- Black

Specifications

- Work surface size: 18"W x 16"D
- Height of work surface from the floor: ~30" to 42"
- Keyboard tray size: 16"W x 6"D
- Footprint: 22" star-shaped base
- 3" wheels (the front two are locking)

Optional

- Lockable laptop cover
- Locking metal drawer
- Pullout writing platform
- Retractable power cord
- Hook for cable

Laptop Cart LPC200

Our laptop cart # LPC200 has integrated handles on the front and rear for ease of maneuverability. All major contact surfaces are made with antimicrobial material with smooth and contoured surfaces. Sliding mouse tray accommodates left and right hand users. An additional base weight increases stability of the laptop cart. We offer multiple color combinations for easy identification and match surrounding decor.

Optional **Hot Swappable Power Supply** (see page 8) provides uninterrupted power to your workstation wherever and whenever you need it. Simply swap out the drained out battery from the cart for a fully recharged battery in no time from the recharging station for continuous workflow.

Features and Benefits

- Thorough disinfection for clean room use
- Built exclusively from cold-rolled steel with epoxy-powder-coated finish
- Integrated handles on the front and rear
- Pneumatic height adjustment
- Right and left slide-out mouse tray
- Additional accessories available (see page 34)

Available Colors

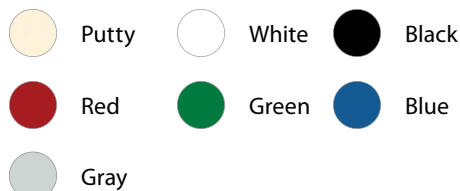

Specifications

- Work surface size: 18"W x 25"D
- Height of work surface from the floor: ~28" to 44"
- Footprint: 23" diameter five-prong base
- Five 4" twin casters (the front two are locking)

Optional

- Hot Swappable Power Supply / LiFe (lithium Iron battery) / Sealed Lead Acid battery (see page 8)
- Laptop lock shelf
- Wire basket
- Mouse/scanner holder
- Retractable power cord

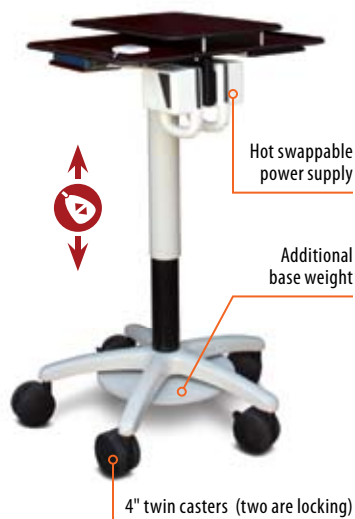

Laptop Cart # LPC200 with laptop lock shelf



A. Laptop Cart # LPC200

- 18"W x 14"D laptop lock shelf
- 18"W x 25"D HDPE work surface with handle
- Slide-out mouse tray
- Additional base weight for increased stability

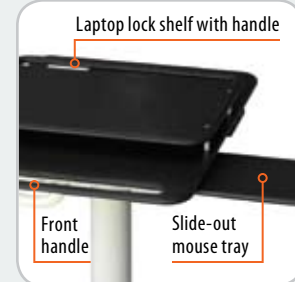

Built-in handles on the front and rear for ease of maneuverability

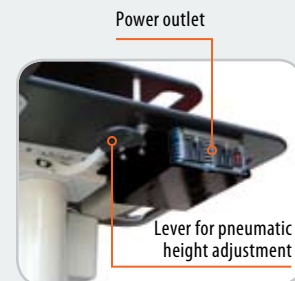

Easy-to-see battery gauge mounted in clear sight makes assessing battery status a snap



Swappable batteries exchange easily and are positioned at an optimal work height to eliminate bending or squatting



Laptop Cart LPC100

B. Laptop Cart # LPC100 with wire basket

- Pneumatic height adjustment
- Height of work surface ranges from the floor: 27" to 37"
- Wire basket # WB-100
- Five 4" twin casters (the front two are locking)



C. Laptop Cart # LPC100-SS with stainless steel top

- Pneumatic height adjustment
- Height of work surface ranges from the floor: 27" to 37"
- 24"Wx24"D stainless steel top
- Handle
- Five 4" twin casters (the front two are locking)



D. Laptop Cart # LPC100 with drawer

- Pneumatic height adjustment
- Height of work surface ranges from the floor: 31" to 41"
- Locking drawer
- Handle
- Five 4" twin casters (the front two are locking)



E. Laptop Cart # LPC100 with wood top

- Pneumatic height adjustment
- Height of work surface ranges from the floor: 27" to 37"
- 24"W x 24"D wood top
- Storage space
- Five 4" twin casters (the front two are locking)



Laptop Cart LPC400 (with a fixed height)



Specifications

- 20"W x 20"D phenolic work surface with two built-in handles on two corners
- Height of work surface from the floor: 42"
- Shelf for CPU/UPS or battery: 18"W x 18"D

Tablet Cart LPC300

F. Tablet Cart # LPC300 with Z-series tablet holder and metal enclosure

- Pneumatic height adjustment
- Tablet holder on Z-arm # AFCZ566
- Metal enclosure
- 18"W x 25"D phenolic work surface with handle
- Height of work surface ranges from the floor: 30" to 42"
- Right and left slide-out mouse tray
- Wire basket # WB-100
- Footprint: 23" diameter five-prong base
- Additional base weight for increased stability
- Five 4" twin casters (the front two are locking)

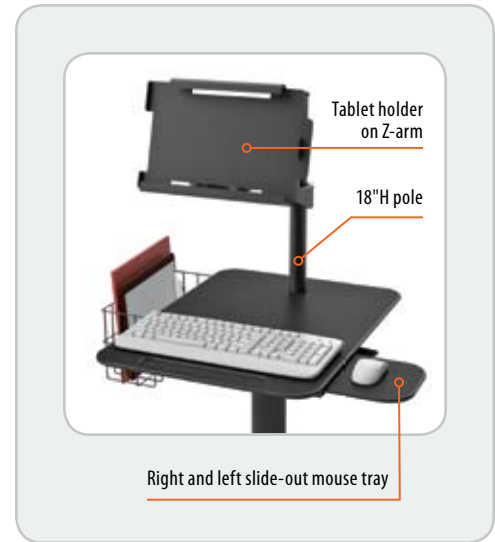
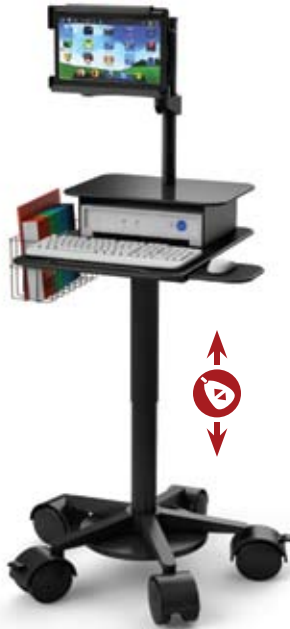

G. Tablet Cart # LPC300 with grommet-mount tablet holder and metal enclosure

- Pneumatic height adjustment
- Grommet-mount arm # AFC01 with tablet holder
- Metal enclosure with removable side covers
- 18"W x 23"D phenolic work surface with handle
- Height of work surface ranges from the floor: 30" to 48"
- Both surface can tilt independently
- Footprint: 23" diameter five-prong base
- Additional base weight for increased stability
- Five 4" twin casters (the front two are locking)



Plasma Cart™

As technology has become an integral part of the workflow, the need for easy, convenient data access has grown. The **Plasma Cart™** is a durable, sturdy, and adjustable mobile solution for data and video access. Applications include teaching and training, meetings and presentations, teleconferences, telemedicine, signage and more, spanning sectors including government, military and other mission critical, commerce, healthcare, education and beyond.

The **Plasma Cart™** allows you to strategically bring a large flat screen and related electronic equipment wherever they are needed. It accommodates large flat screens with

allowing tilt from -5° to +15°. All components of the **Plasma Cart™** are height adjustable. Internal wire management is enclosed by easy-to-remove access panels.

The **Plasma Cart™** can be configured according to the user's specific needs and enhanced with multiple options, such as double-monitor holder, retractable keyboard and laptop tray, additional shelves, CPU holder, camera holder for teleconferencing, telemedicine, and filming applications.

Our **Mini Plasma Cart™** series accommodate screens between 24"– 38" and have all standard features of **XLCD** series in a smaller footprint with the option for height adjustable components.

¹ Will work with smaller sizes and depending on the weight of the screen



Plasma Cart™ XLCD200-01

Features and Benefits

- Fits multiple size flat screens
- Monitor mount tilts from -5° to +15°
- Mobile and stable
- All components are individually height adjustable
- Built-in cable management with removable access panel

Specifications

- Utility shelf: 18"W x 16"D
- Footprint: 30"W x 30"D
- Four-inch casters (the front two are locking)
- Overall height from the floor: 62"

Optional

- Multiple monitor holder
- Retractable keyboard/laptop tray
- Additional shelves
- CPU holder
- Camera holder
- Surge suppressor
- Glides and additional accessories

Colors

- Textured Gray
- Black

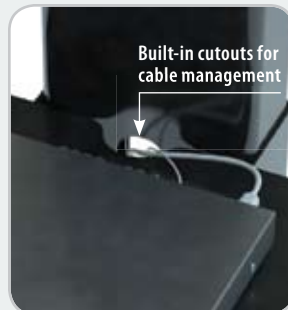

Built-in cutouts for cable management



A surge suppressor can be mounted out of sight, inside the cable management channel



Built-in cable management provides a neat and safe solution for wires, which are tucked away behind an easily removable access panel



Plasma Cart™ XLCD200-01 (front view)



Plasma Cart™ XLCD200-01 (back view)

A. Plasma Cart™ XLCD500

- Monitor Arm # AFCZ5-00
- Retractable Keyboard Arm & Tray # WM-TR-M with slide-out Mouse Tray
- Handle
- CPU Holder # CPU 13-25
- CPU Holder # CPU-101
- Footprint: 30"W x 30"D



B. Plasma Cart™ XLCD500

- Two Monitor Arms # AFCZ5-00
- Z-series Keyboard Arm & Tray with retractable Mouse Tray # WM-ZKB-1
- Handle
- Two utility shelves
- Printer shelf
- Footprint: 30"W x 30"D



C. Mini Plasma Cart™ MLCD200-01

- Monitor Arm # AFCZ5-00
- Retractable Keyboard Arm & Tray # WM-TR-M with slide-out Mouse Tray
- Utility shelf: 18"W x 18"D
- CPU Holder # CPU 13-25
- File/cassette holder
- Shelf for UPS: 14"W x 12"D
- Footprint: 24"W x 24"D

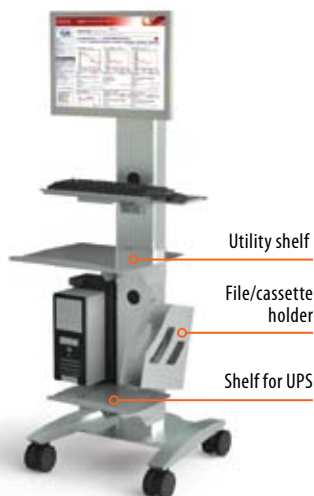

D. Mini Plasma Cart™ MLCD400-01

- Monitor Arm # AFCZ5-00
- Lockable enclosure with retractable Keyboard Tray and slide-out Mouse Tray
- Wire Basket # WB-100
- CPU Holder # CPU-101
- Straight base: 30"W x 26"D



Pole Cart™

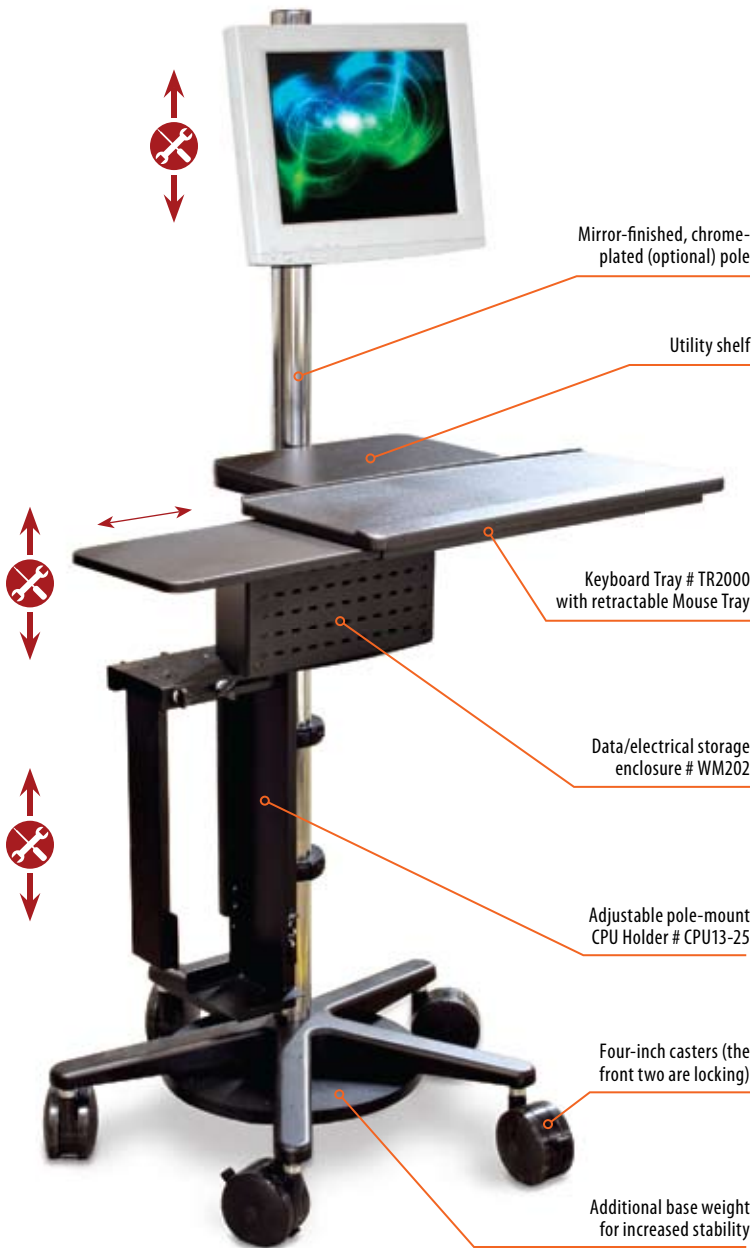

Pole Cart™ MPC200

The compact size and adaptable nature of the Pole Cart™ make it highly useful in a variety of applications and perfect for tight, high-traffic areas. It easily moves a computer system from one location to another and supports up to two flat-panel monitors, a keyboard, and a CPU.

The Pole Cart™ can be adjusted from a seated to a standing position.

Features and Benefits

- Steel pole with built-in wire management (View B)
- Available with laminate, square metal base, or five-prong metal base
- All individual components are height-adjustable and can be rotated 360 degrees around the pole
- Pole finish:
 - Mirror-finished chrome-plated or
 - Multiple colors available (for standard colors, see page 39)
- Additional accessories available (see page 34)

Specifications

- Pole: 2" outside diameter
- Footprint:
 - Square base — 21"W x 21"D
 - Five-prong base — 26" diameter
- Four-inch casters (two of them locking)
- Overall height from the floor: 60", 72"



View A
Pole-mount Monitor Arm # AFCZ5-00 with tilt & pan movements

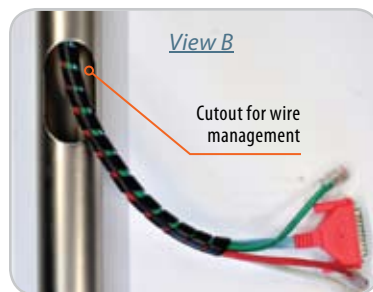

View B
Steel pole with cutouts (two front and one rear) for wire management



Optional Z-series Arm for two LCD monitors # AFCZ588-02

A. Pole Cart™ MPC200

- Black epoxy-powder-coated finish pole with built-in cutout for wire management
- Pole-mount Monitor Arm # AFCZ5-00
- Utility shelf
- Keyboard Tray # TR2000 with retractable Mouse Tray
- Two pole-mount CPU Enclosures # CPU-09
- Additional base weight for increased stability
- Five 4" casters

**D. Pole Cart™ MPC200 with laminate base**

- Black epoxy-powder-coated finish pole
- Pole-mount Monitor Arm # AFCZ5-00
- Laminate utility shelf
- Metal Keyboard Tray with retractable Mouse Tray
- Adjustable pole-mount CPU Holder # CPU13-25
- Laminate base edged with bumper molding
- Four 4" casters

**B. Pole Cart™ MPC200**

- Black epoxy-powder-coated finish pole with built-in cutout for wire management
- Pole-mount Monitor Arm # AFCZ5-00
- Handle
- Utility shelf
- Keyboard Tray # TR2000 with retractable Mouse Tray
- Data/electrical storage enclosure # WM202
- Retractable Power Cord # RPC-101
- Adjustable pole-mount CPU Holder # CPU13-25
- Additional base weight for increased stability
- Five 4" casters

**E. Pole Cart™ MPC200 with square metal base**

- Black epoxy-powder-coated finish pole
- Pole-mount Z-arm # AFCZ588-01
- Metal Keyboard Tray with retractable Mouse Tray
- Adjustable pole-mount CPU Holder # CPU13-25
- Square metal base
- Four 4" casters

**C. Pole Cart™ MPC200**

- Black epoxy-powder-coated finish pole with built-in cutout for wire management
- Pole-mount Twin Monitor Arm # AFCPOLE2MH-1
- Handle
- Utility shelf
- Keyboard Tray # TR2000 with retractable Mouse Tray
- Data/electrical storage enclosure # WM202
- Retractable Power Cord # RPC-101
- Two pole-mount CPU Holders # CPU-101
- Additional base weight for increased stability
- Five 4" casters

**F. Pole Cart™ MPC200 with square metal base**

- Black epoxy-powder-coated finish pole
- Pole-mount Z-arm # AFCZ588-02
- Keyboard Tray # TR2000 with retractable Mouse Tray
- Adjustable pole-mount CPU Holder # CPU13-25
- Square metal base
- Four 4" casters



As telemedicine rapidly develops where medical information is transferred for the purpose of consulting, and sometimes remote medical procedures or examinations, AFC Industries offers the **Pole Cart™** equipped with a camera holder.

Useful for bedside patient interaction from your home or office, or when health professionals discussing a case over the telephone, or as complex as using satellite technology and videoconferencing equipment to conduct a real-time consultation between medical specialists in two different countries.



G. Pole Cart™ MPC200

- Gray epoxy-powder-coated finish pole with built-in cutout for wire management
- Height-adjustable camera holder
- Pole-mount Twin Monitor Arm # AFCPOLE2MH-1
- Handle
- 18"Wx16"D shelf with drawer
- Speaker shelf
- Wire basket # WB-100
- Pole-mount CPU Holder # CPU-101
- Additional base weight for increased stability
- Five 4" casters

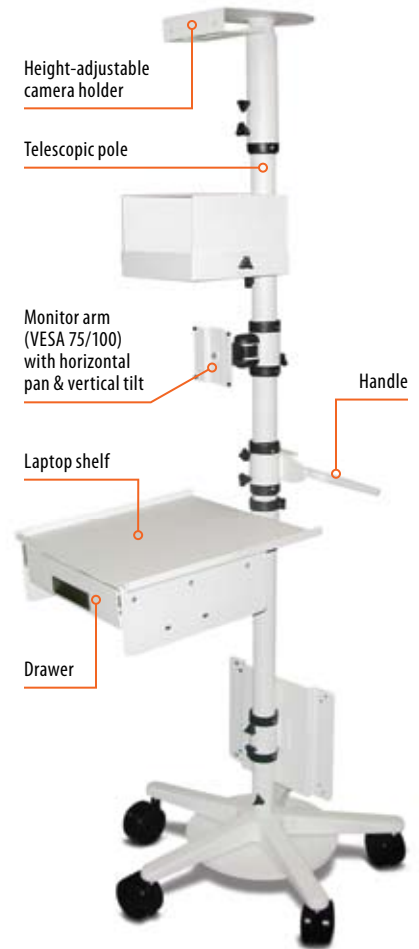

I. Pole Cart™ MPC600_CSX_07

- Gray epoxy-powder-coated finish telescopic pole
- Height-adjustable camera holder
- Transmitter holder
- Pole-mount Monitor Arm # AFCZ5-00
- Handle
- Laptop shelf with drawer
- Mounting bracket for transformer
- Additional base weight for increased stability
- Five 4" casters



H. Pole Cart™ MPC200

- Mirror-finished, chrome-plated pole with built-in cutout for wire management
- Pole-mount camera shelf
- Pole-mount Monitor Arm # AFCZ5-00 with tilt & pan movements
- Pole-mount scanner Holder # S01
- Handle
- Pole-mount laptop platform
- Pole-mount CPU cradle
- Wire Manager
- Base-mount CPU cradle
- Additional base weight for increased stability
- Five 4" casters



Pole Cart™ is perfect for tight, high-traffic areas

We also offer a Pole Station™ with a round metal base that is fixed to the floor¹

J. Pole Station™ # FPP

- Gray epoxy-powder-coated finish pole with built-in cutout for wire management
- Z-series Monitor Arm # AFCZ588-01
- Z-series Keyboard Arm with retractable Mouse Tray # ZKB-P
- Pole-mount CPU Holder # CPU-101
- Floor-mounted 16" diameter metal base



K. Pole Station™ # FPP

- Black epoxy-powder-coated finish pole with built-in cutout for wire management
- Pole-mount Monitor Arm # AFCZ5-00
- Two utility shelves
- Pole-mount Scanner Holder # S01
- Metal Keyboard Tray with retractable Mouse Tray
- Two Wire Baskets # WB-100
- Pole-mount CPU Holder # CPU-101
- Printer shelf
- Floor-mounted 16" diameter metal base



¹ Has to be bolted

MOUNTING SOLUTIONS



Mounting solutions make the most of limited-space and decentralize data access

High traffic areas. Tight places. Operating rooms and emergency rooms. Inside and outside patient rooms. These are just some of the areas that are perfectly suited for AFC's variety of mounting solutions. Height-adjustable versions for seated or standing positions. Adaptable to any user. Making empty wall space productive.

Available in reach wood laminates, creating a warm and welcoming environment, as well as technical models traditionally associated with healthcare institutions. Decentralizing the availability of data for a greater return on investment in plant and human capital.

i-Center™

The innovative, space-saving **i-Center™** is an attractive wall-mounted workstation that enables computer access wherever needed, without utilizing floor space. The **i-Center™** includes a fold-down keyboard tray with a damper for smooth operation and a VESA-compliant monitor holder. It accommodates any standard computer and turns empty wall space into a handy work area.

The **i-Center™** features a laminated front and side wall that can be specified to match room décor, and mounts easily with grommet holes to allow cabling. It has a removable front panel with security screws to prevent theft. The **i-Center™** was designed to make the most of limited space in today's busy environments.

New!



Features and Benefits

- Removable front panel with security screws and lock for keyboard shelf prevent theft
- Fold-down keyboard tray with damper for smooth operation
- VESA-compliant monitor holder
- Grommet holes for cabling
- Laminated front and side walls can coordinate with room décor
- Multiple colors available (for standard colors, see page 39)
- Optional accessories include: CPU, fan, mouse holder, scanner holder, and cable management
- Custom sizes available

Specifications

- Width: 21 1/8" – 40"
- Height: 25 1/2" – 50"
- Depth: 6" – 9"
- Keyboard shelf depth: 8"



A. Lockable **i-Center™** 40"W x 6"D x 26 1/2"H with compartments for CPU & medication



B. **i-Center™** 27"W x 6"D x 25 1/2"H with removable front panel and matching CPU holder # CPU-903-18-5-18



C. **i-Center™** 30"W x 6"D x 42"H with matching wall-mount CPU enclosure

D. i-Center™
27"W x 6"D x 25 1/2"H
with holder for thin
client PC and sliding
mouse tray

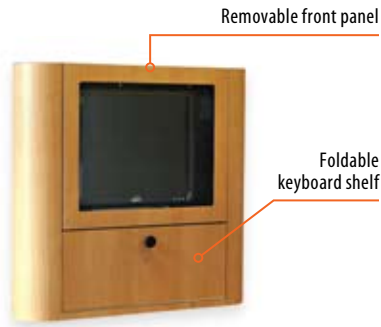

E. Lockable i-Center™
27"W x 6"D x 35"H
with wall-mount CPU
enclosure for small-
form-factor PC and
scanner holder

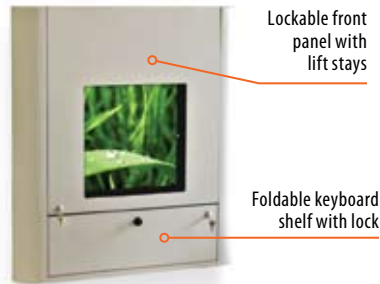

F. i-Center™
25 1/2"W x 6"D x 46 1/2"H
with top flip-open-door
CPU compartment and
sliding mouse tray



G. i-Center™
21 1/2"W x 6"D x 49"H
with two-door CPU
compartment, mouse
holder, and sliding
mouse tray



New!

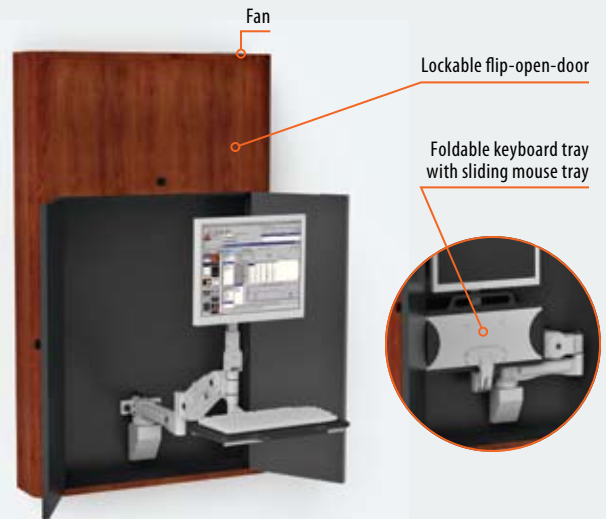

**H. i-Center™ with top
flip-open-door CPU
compartment and
AFC7810_12 arm**
(see page 28 for
details on the arm)



Wall Mounts

The wall mounts **AFC7808_12** & **AFC7810_12**, a height-adjustable, low-profile, user-friendly solution for access to electronic records where space is at a premium. The wall mount accommodates most operators, in sit-to-stand positions. When not in use, it folds up neatly to the wall, tucked away and unobtrusive. The flexible **AFC7808_12** and **AFC7810_12** are designed with the ergonomic intelligence, strength, dura-

bility, and thorough disinfection properties like other AFC products, while offering an easy-to-operate tool for boosting productivity any high-traffic areas. They are pneumatically height-adjustable within a 12" range, and can be locked in any position you chose. Full range of swivel motion at each joint comfortably accommodates different positions and applications, such as sharing information with patients and other professionals in proximity.



Wall Mount # AFC7808_12 with CPU holder # CPU101

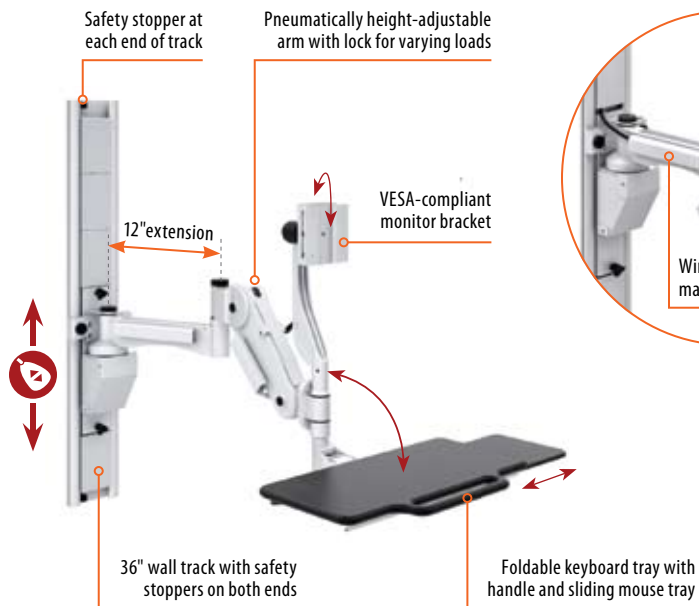

Wall Mount # AFC7808_12

12"

Height locking lever

LCD vertical adjustment
3"

12-inch range of height adjustment accommodates most users while standing or seated

Tilting display eliminates overhead glare



Vertical mounting



Horizontal mounting



Desktop mounting

Features and Benefits

- Light-weight aluminum construction for easy operation
- Entire mount is powdered coated in anti-microbial paint for thorough disinfection for safe use throughout medical facilities (available only in gray)
- 41" of horizontal extension from the wall with option of supplemental one foot extension arm
- 12" range of height adjustment for accommodation of most users while standing or seated
- Height locking mechanism at any position for safety, stability, and varying loads
- Full range of swivel motion at each joint
- Keyboard folds for low profile and has a safety lock
- Mouse tray can be attached to the left or right side of the keyboard
- Mouse holder is included
- VESA 75/100 compliant monitor bracket with horizontal and vertical tilt and 3" range of height adjustment
- Standard color: Textured Gray (call for custom colors)
- Integrated wire management
- Arm vertically adjusts on 24" or 36" wall track (wall track is optional)
- Can be mounted directly on a wall or desk

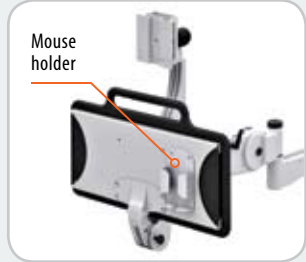
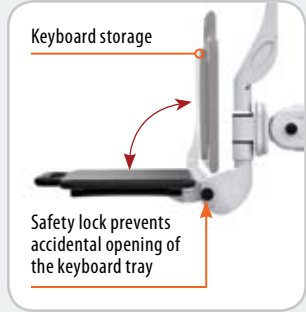

With the keyboard folded up, total system depth is as little as about 8"

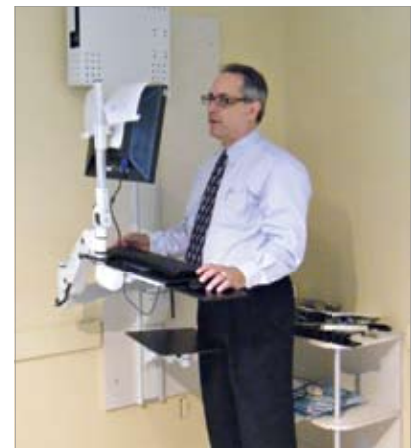

Wall Mount # AFC7810_20 with CPU holder # CPU-919 and shelf on articulating arm

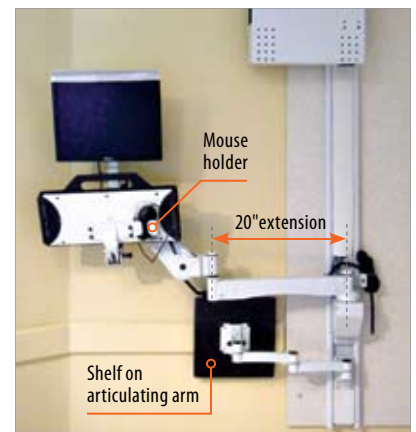
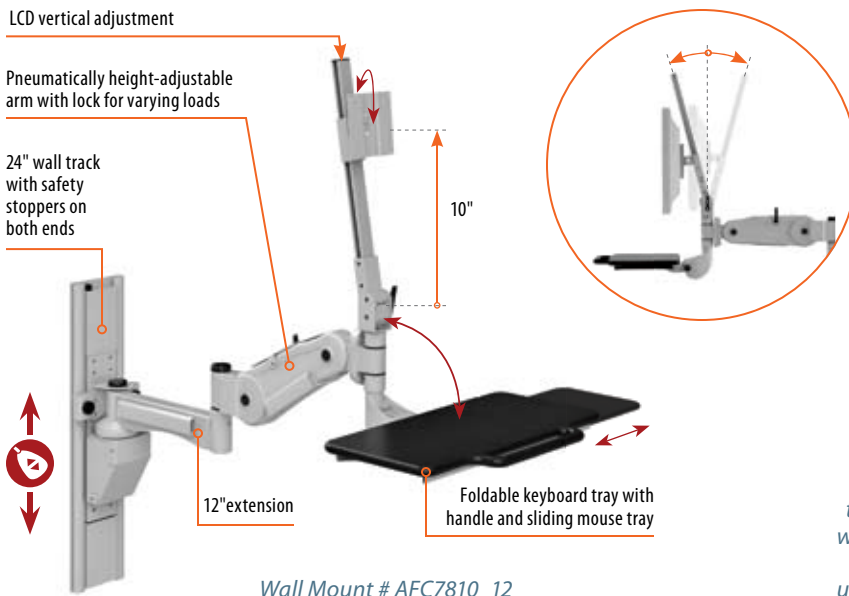

When not in use, it folds up tight to the wall, tucked away and unobtrusive



The flexible wall mount AFC7808_01 allows the user to work at seated or standing position and provides full range of swivel motion at each joint

A. Wall Mount # WM36_AFC7808_01



B. Wall Mount # WM36_AFC7808_01 with CPU holder # CPU-101



C. Wall Mount # WM24_AFC7810_01



D. Wall Mount # WM36_AFC7808_01 with keyboard arm # AFC7808K, and CPU holder # CPU-101



E. Wall Mount # WM24_AFC7808lp_01

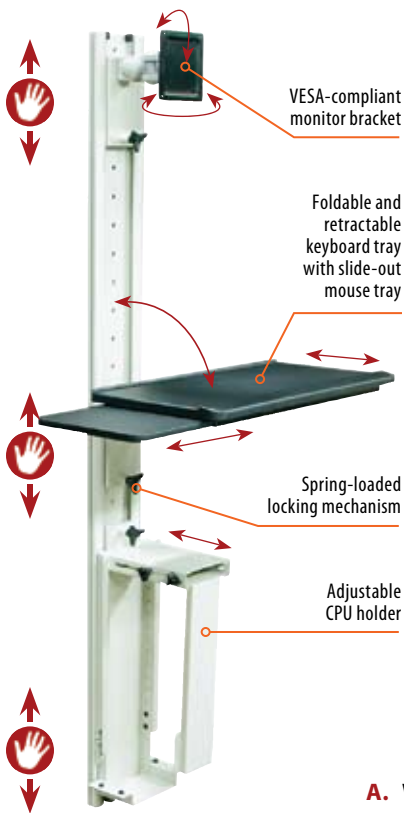

Wall Mount # WM-RKMC

A. Wall Mount with electronic height adjustment # WM202-01

- 19" of electronic height adjustment of the unit
- Components are individually adjustable
- Monitor tilts up and down
- Foldable keyboard tray with slide-out mouse tray
- Adjustable CPU holder # CPU101

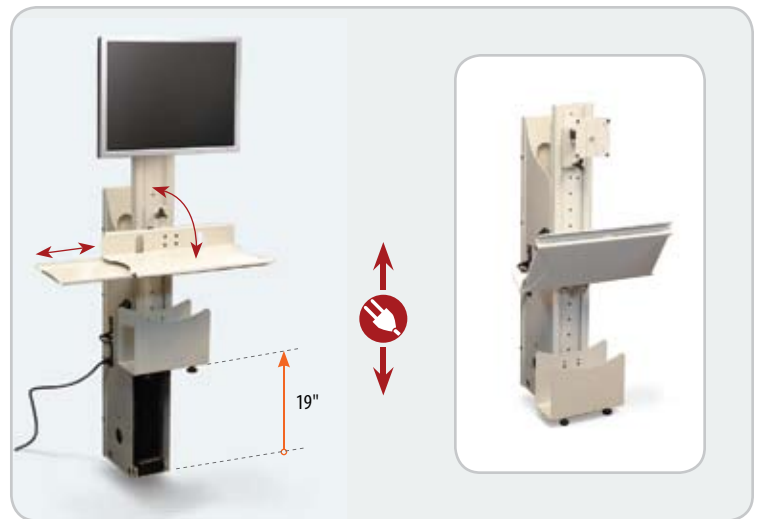

Handles for height adjustment

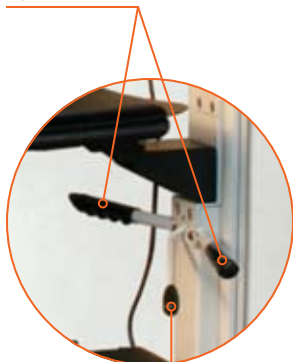

Pneumatic lever

B. Wall Mount with pneumatic height adjustment # WM-RKMC-P-04

- 12" of pneumatic adjustment of the unit
- Monitor tilts up and down
- Retractable and foldable keyboard tray with slide-out mouse tray
- Adjustable CPU holder # CPU 13-25



Standing position



Seated position

Features and Benefits

- All components are individually adjustable in increments of 2"
- Safety stoppers at both ends
- Spring-loaded locking mechanism for simple and easy height adjustment
- VESA-compliant monitor holder that can be adjusted from portrait to landscape view and tilted to avoid glare
- Foldable and retractable keyboard arm and mouse tray
- Adjustable CPU holder (3 1/2"- 8 1/2"W, 13"- 25"H)
- Multiple colors available (for standard colors, see page 39)
- Additional accessories available (see page 34)

Optional

- Horizontal or vertical positioning
- Double monitor holder on single track (see sidebar "Optional Monitor Arms for Wall Mount" on page 31)
- Horizontal track for multiple monitors (see sidebar "More Wall Mount Solutions..." on page 32)
- UPS Holder
- Mouse Holder



C. Wall Mount
WM36-M1-FK-C1¹

1 OSHPD rated



D. Wall Mount
WM56-1F-KB82R-C13_25



E. Wall Mount
WM56-2FZ-KB82R-C13_25



F. Wall Mount
WM56-2FZ-KB82R-U-C13_25



G. Wall Mount
WM56-1F-KBZ-Sh-C101



H. Custom Wall Mount

Optional Monitor Arms for Wall Mounts



Twin monitor arm
2MH



Z-series monitor arm
for one monitor



Z-series monitor arm
for two monitors

Configure your own Wall Mount with our **INTERACTIVE BUILDER** at www.afcindustries.com/wallmount



Foldable shelf on
articulating arm



I. Wall Mount with CPU holder, scanner holder, and foldable shelf # WM56_Z200_CMB_1C_12SH_01



J. Custom Wall Mount with Z-series combo arm, CPU holder, and foldable shelf



K. Custom Wall Mount



L. Custom Wall Mount

More Wall Mount Solutions...



*Wall Mount Pole
WMPL_52_F_KB_C_001*



*Wall Mount for multiple monitors on horizontal track
WM110_3PLE18_3F*



*Laptop Wall Mount
#AFCZ566-01-LWM-01*

Floor Post

The Floor Post Series™ creates a more effective, comfortable, and productive work environment. Based on your specifications, you can have unlimited configurations for any task. Its space saving design also allows multi-side (front/

back/side) user capability. The **Floor Post Series™** can be mounted to various floor surfaces. Monitor, keyboard arms, CPU holders, shelves and other accessories can be made height adjustable on a secure track making the **Floor Post Series™** suitable for multi-users.



▲
Floor Post
FM62_2F_2AFC7808K
4C_00-01

The Floor Post's space saving design allows multi-side (front/back/side) user capability

Features and Benefits

- All components are individually adjustable
- Spring-loaded locking mechanism for simple and easy height adjustment (depending on item)
- Built-in wire management
- Monitor holders of your choice: AFC10E/F/G, AFCZ5-00, AFC7808M_01 (see page 34)
- CPU holders of your choice: CPU-101, CPU13-25, CPU-08, or CPU-09 (see page 37)
- Multiple colors available (for standard colors, see page 39)
- Additional accessories available (see page 34)

Specifications

- Base footprint: 16"W x 16"D
- Overall height from the floor: 60"

Optional

- Double-monitor holder
- Foldable and retractable keyboard arm with slide-out mouse tray
- Additional shelves
- Camera holder



Floor Post
FM50_1F_WS3018
1KB_1C_1WB_00-01



Floor Post
FM50_1F_1AFC7808K
1C_1WB_00-01



Floor Post
FM50_1F_1AFC7808M
1C_1WB_00-01

LCD Monitor Arms/holders

AFC Industries Inc. provides a variety of solutions for mounting LCD monitors. We offer four categories: **Desktop series, Z-series, Wall Mount series, and Ceiling Mount series.**

Our Desktop series includes three types of VESA-compliant LCD monitor arms: grommet-mounted, base-mounted and clamp-mounted.

Combining style with functionality, the Z-series with articulating monitor arms allows you to position your monitor at any viewing level, angle, and depth from the viewer, providing maximum flexibility. The Z-series comes with a clamp that can also be wall-mounted.

Desktop Series

					
Base-mount AFC03	Base-mount AFC03A	Base-mount PEDPOLARM	Grommet-mount AFC01	Grommet-mount AFCRAIL01 (w/ AFC10F)	Grommet-mount AFCRAIL01 (w/ AFC22)
					
Grommet-mount AFC7808_12_DM-01		Clamp-mount AFC02	Clamp-mount AFC11	Clamp-mount AFCFLEXOARM	
					
Clamp-mount AFcPOLE	Clamp-mount AFcPOLE2MV-1	Clamp-mount AFcPOLE2MH-1	Clamp-mount AFc-KM-COMBO	Grommet-mount AFcPOLE2-OP-0	Clamp-mount AFcPOLE2-OP-1

Z-Series

					
AFCZ588-01	AFCZ588-02V	AFCZ588-02	AFCZ588-03	AFCZ588-04	AFCZ588-06

Wall Mount Series

							
AFC10AC	AFC10E	AFC10F	AFC10G	AFC2530	AFCZ5-00	AFCZ6-00	AFCZ660
							
AFC05		AFC11B	AFC12		AFC3255-01		
							
AFCZ560	AFCZ568		AFCZ568-05-WMH				
							
W2M-BAR	W3M-BAR		W4M-BAR				
							
WM24_AFC7808M_01	WM24_AFC7808_01	WM24_AFC7808-12_01	AFC109-KM-01				
			 <i>Monitor Arm for LCD monitors of sizes ranging from 32" to 50"</i>				
AFC135	WM110_4PLE18_4F		WM-AA-3250-UP-LB22				

Ceiling Mount Series

The **Ceiling Mount** is a simple but sturdy LCD monitor arm that allows users to adjust the monitor at their required height and viewing angle. It also allows rotation and tilt positioning of the monitor. Cables can be wired through the tubing for connection to the monitor.

Ceiling Mounts come with a standard VESA 75/100 plate. Non VESA-compliant monitor holders are also available for large-scale LCD monitors.



B. LCD Ceiling Suspension # CM-LCD1

C. LCD Ceiling Suspension # CM-LCD4



D. LCD Ceiling Suspension # CM-LCD2

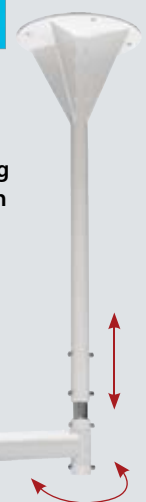

E. Ceiling Mount # AFC107

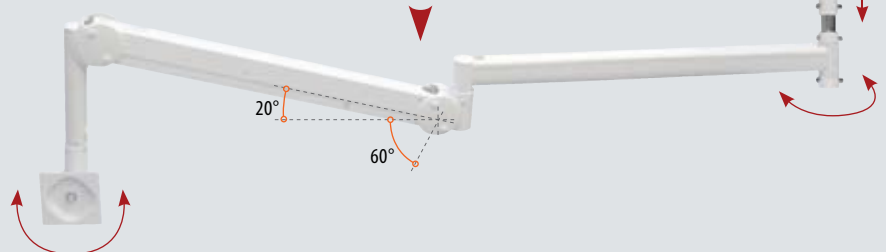

F. Custom Ceiling Mount for 2 large LCD monitors with CPU compartment



G. Ceiling Mount for large LCD monitors # CMZ-1FZ-V1X3

Laptop Arms

Wall-mount WM24_AFC7808LP_01

Wall-mount AFCZ566-01-LWM-01

Desk-mount AFCZ566-01-LPM-01

CPU Holders

					
Desk-mount CPU-01	Desk-mount CPU-03	Desk-mount CPU-05	Desk, pole, or wall-mount CPU 13-25		Desk-mount CPU-17
					
Wall-mount CPU-06	Wall-mount CPU-08	Wall-mount CPU-903-18-5-18	Wall-mount CPU-16-AFC22	Wall-mount CPU-919	Wall-mount CPU-CS909
					
Wall-mount CPU-09	Wall-mount CPU-801-WD	Wall-mount CPU-101	Base-mount CPU Cradle CPU-07	Base-mount CPU-99	Mobile CPU Cradle CPU-02

Phone Arms







Phone Arm TA001

Phone Arm TA002

Phone Arm TA004B

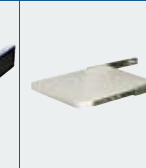
Dictation Arm TA003B

Keyboard, Mouse, and other Accessories

					
Keyboard Arm & Tray WM24_AFC7808K_01	Keyboard Arm KA6000	Keyboard Arm KA3656	Keyboard Arm KA7001	Keyboard Arm & Tray WM-TR-M	Keyboard Arm & Tray WM-ZKB-1
					
Keyboard Tray TR1000	Retractable Mouse Tray	Ergonomic shape	Retractable & foldable	Retractable	Keyboard Storage Drawer KSD01
					
Keyboard Storage Drawer KSD01	12"W x 14"D x 1.5"H Pencil Drawer PD002	Wire Basket WB-100	Metal Film Box FB-100	Scanner Holder S01	Cup Holder MCH-100
					
Antiseptic Wipe Holder AWH100	Biohazard Waste Holder BWH100	Mouse Holder M001	Palm Rest PAL1000	Rotary Mouse Platform RMP-1	Keyboard Wrist Rest WR006

Cable Management and Power Solutions

 Length: 12", 24", 36"	 A - 1 7/8" x 1"H B - 7/8" x 1/2"H	 Diameter: 1", 1/2"	 Diameter: 1/2"
Cable Manager WM201	Cable Manager WM100	Corrugated Wire Hose WMF200A, B	Cable Wrap WM-400
 Diameter: 0.5" - 0.75"	 Diameter: 2", 2 3/4"		 Length: 30", 60"
Wire Clip WC100A	Grommet Outlets GROM-2, GROM-3	In-Desk USB Hub USB-04	
			
Portable AC Power System PS-TL-1	Surge-Suppressor Power Strip SS9000	Retractable Power Cord RPC-101	
			
Data & Power Ports DPA-01	Power Strips SS9003 (8 Plugs) and SS9004 (24 Plugs)	Cable Ties 10 CM03	

COMPLIMENTARY SERVICES

FREE on-site consultation

At AFC we want to get it right the first time, every time, to create a great custom environment for our Customers. That's why we will come to you to ensure we are maximizing your space and that everything is measured up just right. We will work with your team, at no charge to you, from the beginning to the end of your project.

FREE project support

Our team is here to assist you with your vision. We have the experience to help with your project and pride ourselves in going above and beyond to not just meet, but exceed your expectations.

FREE design service

We want to use our many years of experience creating spaces to take full advantage and help you go beyond your imagination. With some of the most mechanically advanced products, we will help you achieve your goals, all at no additional cost to you.

Glides & Casters

		
Adjustable Glide GLID-ADJ	2" Twin Caster w/ brake CAS-2TB	3" Caster CAS-3
		
4" Caster CAS-4	4" Caster w/ brake CAS-4B	4" Caster w/ brake CAS-GPB
		
4" Caster w/ brake CAS-PB	5" Caster w/ brake CAS-5B	

and more...

LED Task Light TAL400

Printer Shelf/Rolling Shelf RS102-1818-01

Slatwall

Customization

AFC can easily customize all products to adapt to your professional and individual requirements. Whether you need help choosing the right components to configure a product or are considering a complete room redesign, our staff is committed to offering you assistance every step of the way.

Outstanding customer support

Our experienced sales and engineering teams are here to walk you through the process from the smallest to largest jobs. Building rapport with our customers is a driving force throughout the relationship and is maintained during the entire project including follow-up.

Anti-microbial paint



AFC now offers the added protection of anti-microbial powder-coat finishes on its products to provide protection against a broad spectrum of micro-organisms. When applied to mobile carts, wall mounts, and work stations the risk of spreading harmful bacteria and viruses between patients and health care workers is greatly reduced, according to doctors using the anti-microbial powder coating in their hospitals and laboratories.

High-density polyethylene (HDPE) top now available with antimicrobial protection

A new kind of antimicrobial protection upgrade now available in many of AFC's polymer sheets, slabs and massive shapes. HDPE helps products stay cleaner between cleanings and inhibits the growth of product-damaging microorganisms, including bacteria, algae and fungi on the surface. Microbe cell walls that come into contact with HDPE are destroyed on contact, without creating opportunities for adaptive or resistant strains to form. Because the antimicrobial agent is bonded at the atomic level throughout the sheet, it will not leach out of the product. This means the agent retains its effectiveness throughout the life of the product and does not harm the environment.

It is safe, non-toxic and non-hazardous to ship and handle. The product is EPA-registered and listed with the FDA as a modifier to medical devices.

Products made using AFC's polymers with HDPE are easy to clean, disinfect and keep hygienic using standard cleaning procedures. Constant use of cleaning solutions will not affect any polymer.

Standard Colors

Laminate

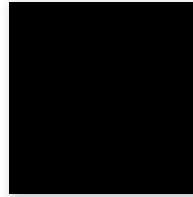

Black

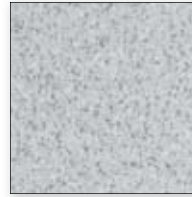

Speckled Gray

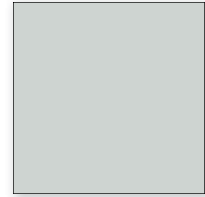

Gray

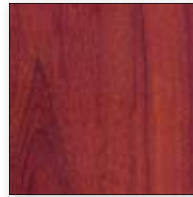

Mahogany



Wild Cherry

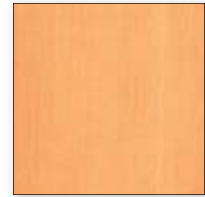

Natural Pear

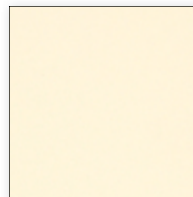

Putty

For any other color
call us at 1.800.663.3412

Phenolic plastic



Black

Ask about our anti-microbial powder-coat finishes!

Molding



Black

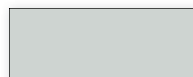

Gray

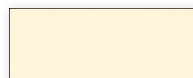

Putty

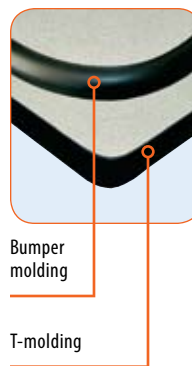
Bumper
molding

T-molding

Frame



Black

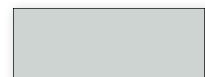

Gray

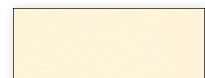

Putty



13-16 133rd Place • College Point • NY 11356



Scan here with your smart phone to visit our website

PRSR STD
US POSTAGE
PAID
OMAHA, NE
PERMIT N^o 449

Thanks

Complimentary Services

AFC Industries, Inc. is here to help you create the most comfortable and productive work environment possible. Our high-quality customer care includes complimentary 3-D product blueprints for all customized designs and detailed floor plans of your facility.

We welcome the opportunity to discuss your needs and find the best furniture solution for your business.

Custom Designs

Rigorous Quality Control



Delivery

We deliver our products fully assembled to ensure maximum quality and convenience for our customers.

Customer Support

1.800.663.3412

Contact Us

Tel: 1.718.747.0237
Fax: 1.718.747.0726

Visit Us

www.afcindustries.com