



er

Catalog

Issue 22, Vol. 1

o

c

m

ergonomic environments in

www.afcindustries.com

t



a

e

n

AFC Industries & ergonomics

Ergonomics is concerned with the 'fit' between the user, equipment and their environments. It takes account of the user's capabilities and limitations in seeking to ensure that tasks, functions, information and the environment suit each user.

To assess the fit between a person and the used technology, we consider the job (activity) being done and the demands on the user; the equipment used (its size, shape, and how appropriate it is for the task), and the information used (how it is presented, accessed, and changed).

At AFC Industries, the emphasis is on ergonomics and functionality. Why? The answer is simple: because the consequences of poorly designed objects and environments — especially at work — are serious and costly.

At a minimum, poorly applied ergonomics can cause schedule delays, recurring discomfort, or a decrease in performance or output. At the extreme, the consequences can be permanent injury.

We human beings are amazingly adaptable. Practically speaking, even under the most adverse conditions, the job must somehow get done. We routinely adjust to the task, furniture or equipment that we have been given. However, there are costs associated with this adaptation. Many of the serious problems on the job fall under the categories of Cumulative Trauma Disorders (CTD), or Repetitive Motion Injuries (RMI). These costly injuries are often a specific result of the body's adaptation to a repetitive task or an inappropriate posture. Their effects are widespread and often have long term consequences. By all accounts, there is a serious, quantifiable impact when ergonomic issues are not dealt with in the workplace. It is a rising cost that cannot be ignored, and good design is a valuable component of the solution.

At AFC Industries, our mission is to create solutions that increase productivity, while maintaining an effective and efficient workplace. Our products include a wide array of height adjustable workstations, carts, wall mounts and racking systems that suit virtually every use, physical space and end user. Our products provide data access when and where it is needed throughout work facilities.

Our engineers are always available to assist with the design elements and spatial relationships you need, and we supply two and three dimensional drawings of all our projects before you order. All manufacturing is done in the USA, and, we deliver our units fully assembled saving the customer time and effort.

AFC Industries, solutions that increase productivity!



p. 43



p. 18



p. 76

Contents

The Science Behind The Ergonomics

004 The Cone of Light

Interactive Workstations

- 007** The Whitestone™
- 010** Deluxe Ergo Tier Cart™
- 013** Ergo Tier Cart™
- 018** Dual Tier Cart™
- 022** Single Tier Cart™

Mobile Data Access

- 029** PC (Point-of-Care) Cart™
- 039** Laptop & Tablet Carts
- 044** Telescopic Cart™
- 047** Plasma Cart™
- 050** Pole Cart™

Carts & Racking Systems

- 055** SmartRack™
- 058** IntelliCart™
- 060** SmartCart™
- 066** OmniBus™
- 068** Medical Equipment Cart

Mounting Solutions

- 071** i-Center™
- 074** Combo Arms AFC7808 & AFC7810 Series
- 077** Wall Mounts
- 080** Video Wall
- 082** Floor Post

Adjustable Detector/Cassette Holders

- 085** Spine Smart™
Digital Radiography Detector Holder
- 086** MACH-ONE™
X-ray Cassette Holder

Healthcare Security

- 089** Control Pod Consoles
- 091** Open Control Consoles

Accessories

- 093** Partitions
- 095** LCD Monitor Arms/ Holders
- 099** Laptop Arms
Phone/Dictation Arms
CPU Holders
Keyboard, Mouse, and other accessories
- 100** Lighting
Glides & Casters
Cable Management and Power Solutions
- 101** Storage Accessories

Complimentary service

- 102** From concept to installation
- 103** Standard Colors

The Cone of Light

“The goals of ergonomics in imaging informatics include improving radiologist comfort, preventing repetitive stress injuries, reducing eyestrain, and improving efficiency.”

Ergonomics is a field of study that focuses on the redesign of work environments to better suit human body mechanics. The goals of ergonomics in imaging informatics include improving radiologist comfort, preventing repetitive stress injuries, reducing eyestrain, and improving efficiency. This is accomplished by creating workstations that adapt to individual users and are designed for specific tasks.

Lighting considerations are of particular importance in the radiology reading room — glare on computer screens and excess ambient light can contribute to radiologist fatigue as well as a decrease in productivity and diagnostic accuracy.

In the real world, reading rooms can become very hot and stuffy from the heat generated by robust monitors and CPU's. To combat this claustrophobic environment, often times the room's door is left open for ventilation and ambient lighting. However, this can lead to a problem with screen glare from the Cone of Light. Simply stated, the Cone of Light is created by the vector points generated from an external light source (See image below).

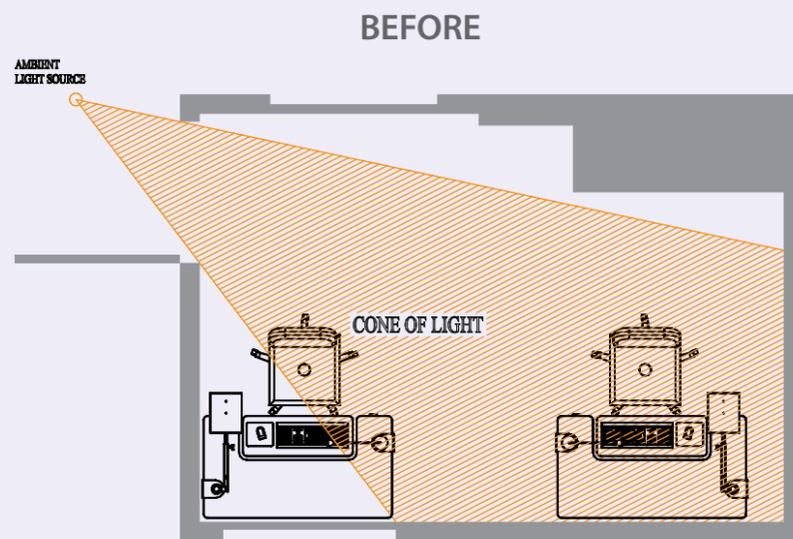

At AFC Industries, our engineers will work with your staff to audit your intended workspace. This will provide the optimum ergonomic solutions necessary for the room such as:

- Insuring that the electronic height adjustment of the work surface and the monitors are quick and silent
- Users ability to read/work, type while standing up
- Work surface height is matched to comfortable armrest height
- Monitor height and tilt is adjusted to user comfort and independent of the table surface (*this variable is accomplished by our electronically height adjustable table which is independent of the electronically height adjustable monitor*)
- Footrest is critical to the relief of low back stress
- Monitor-eye distance should be adjustable
- The proper use and positioning of partitions to neutralize the glare from the Cone of Light (See image below).

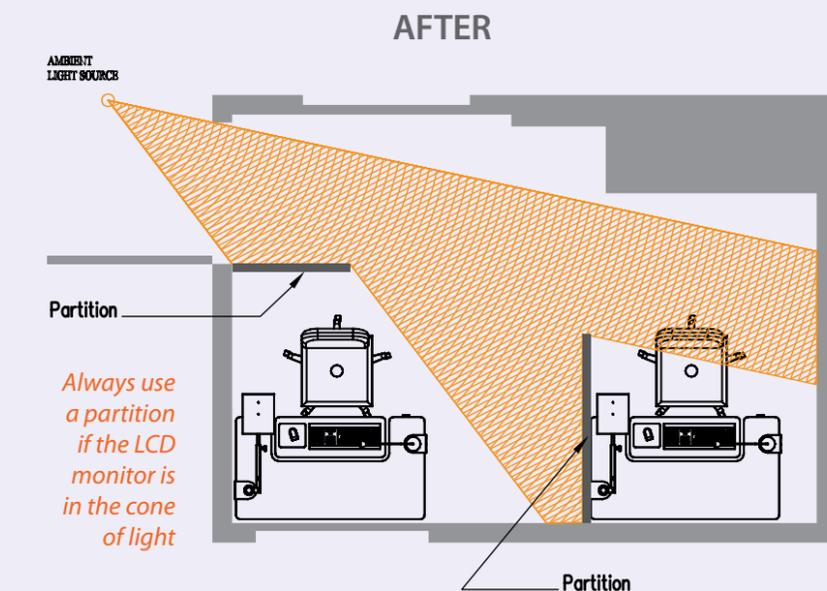

Electronic adjustment, at the touch of a button, of the work surface height and independent monitor positioning for height and focal length



The greatest benefit of a height-adjustable workstation is the ability to change posture and work seated or standing up

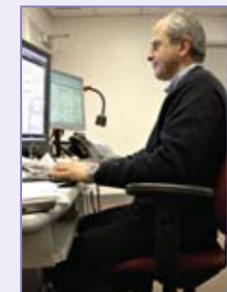

The individual's maximal comfort prevents repetitive stress injuries and improves efficiency



Partitions prevent interference from monitors or other light sources, absorb sound and provide privacy



Flexible. Adjustable. Adapt to you!

Sit. Stand. Raise monitors. Lower monitors. Move them in. Move them out. These are the building blocks of an ergonomic workstation.

Different users. Different needs.

AFC workstations. Electronically height-adjustable at the touch of a button. Independent adjustment of monitor height and focal length for optimal viewing. Digital readouts to preserve and easily return to your ideal settings for surface and monitor placement. Available with surface tilt. A host of valuable features—ambient LED backlighting to ease eye strain and improve reading quality; a variety of monitor platforms; mounting solutions for the growing interest in large monitors; acoustical privacy partition to improve concentration; pop-up data port and built-in USB hub to facilitate neat and tidy use of ancillary equipment. And more.

Our flexible workstations and carts come in a wide variety of sizes, shapes, multi-tiered designs, and color options that accommodate virtually any location and workplace need. They can be enhanced with cabinetry, shelving, computer storage, and retractable features.

AFC workstations. Helping you perform better.

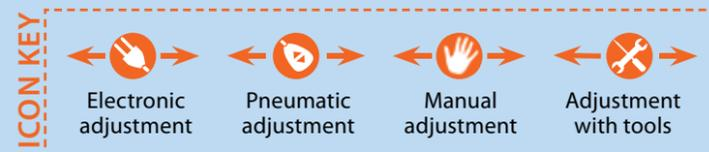

The Whitestone™

The Whitestone™ workstation is AFC's radiology dream station, loaded with valuable enhancements as well as a full array of electronics, lighting, power and cable management that facilitate performance, comfort, and ease of use.

Complete electronic adjustment capabilities are the foundation of this highly adaptable workstation—for surface height in sit or stand positions, surface tilt, and both vertical and horizontal adjustment of monitors. Digital readouts for all workstation settings—surface and monitor height and monitor focal length — enable every user to customize, preserve, and easily restore optimal settings.

The monitor bracket supports large monitors weighing up to 50 lbs, responding to a growing interest in

larger images. We have added acoustical properties to our wraparound privacy partition to reduce extraneous sounds and create a more quiet environment for concentration.

Ambient LED backlighting with dimmer control alleviates eye strain and improves the readability of images. A pop-up data port and USB unit is built into the work surface for convenient and tidy connection of almost any ancillary digital or electronic device. Multi-channel cable management keeps wires neat and

unobtrusive and allows for important separation of power and electric wiring. An environmental heating and cooling system controlled at the workstation allows for direct regulation of temperature and alleviates heat generated by computer equipment.

The Whitestone™— delivering superior comfort and adaptability to the requirements of different users and the demands of the evolving digital world.





Electronic Adjustment:

- SURFACE HEIGHT
- SURFACE TILT
- MONITOR HEIGHT
- FOCAL LENGTH

Features and Benefits

- Electronic adjustment of work surface height and tilt
- Independent electronic adjustment of monitor height and focal length (forward/backward motion)
- Monitor bracket # AFC2530 supporting up to 50 lbs
- Digital readout of surface height
- Digital readout of monitor height and focal length, with memory settings
- Pop-up data ports and a built-in USB hub embedded in the work surface (see photo on page 9)
- Ambient LED backlighting with dimmer switch (see photo on page 9)
- Acoustical partition that reduces noise
- Advanced warm/cool air environmental control system regulated at the workstation (optional)
- Cold-rolled 11-gauge steel frame with epoxy-powder-coated finish
- Particle-board-core top with high-pressure laminate finish edged with bumper molding
- Split bottom shelves
- Multiple colors available (for standard colors, see page103)
- Wire manager, power strip
- Four-inch casters (two of them locking)

Specifications

- Work surface width: 84"
- Work surface depth: 36"
- Height from the floor:
Work surface: 28" to 47"
Monitors: 38" to 47"

Complete electronic adjustment capabilities of the Whitestone workstation are within easy reach. This allows the radiologists to optimize comfort, preventing repetitive stress injuries, reducing eyestrain, and improving efficiency.



LCD Monitor Arms on telescopic drives with electronic adjustment of monitors' height and focal length

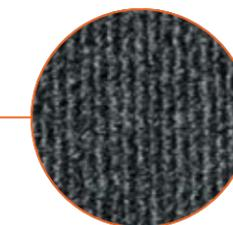

Acoustical partition reduces extraneous sounds to create a more quiet environment for concentration



Adjustable LED backlight with dimmer control alleviates eye strain & improves readability of images



Dimmer switch for LED backlight



Pop-up units include Ethernet network and parallel ports as well as standard AC power outlets and can be customized to a site's particular needs.

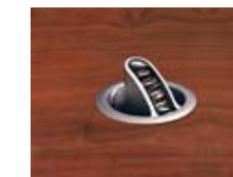

Separate USB units include four ports, so you can easily connect and use almost any digital device while remaining seated



Environmental heating and cooling system controlled at the workstation



Three way rotary switch of our LED Task Light # TAL400 enables user to toggle between white light and red light output



Power strip with 8 plugs and turn on/off switch



Deluxe Ergo Tier Cart™

We're pleased to raise the ergonomic standards bar and to offer radiologists well-designed, durable furniture that reduces the risk of strain and injury, while helping them maximize performance in their mission-critical healthcare role. The **Deluxe Ergo Tier Cart™** is designed to meet the need for easy electronic adjustment, at the touch of a button, of the work surface height and independent monitor positioning for height and

focal length, as well as work surface tilt within a 15° range of motion. Both seated and standing work positions are accommodated, and a digital readout for surface height is standard with the **Deluxe Ergo Tier™**.

Enhancing features for lighting, privacy, computer storage, ancillary equipment, and more are offered on an optional basis. They include an attached wraparound privacy partition suited for rooms occupied

by more than one person; full or split bottom shelves, ambient LED backlighting with dimmer switch, pop-up data ports and a built in USB hub recessed in the work surface; and built-in fans or an advanced environmental control system for warm and cool air.

See **Optional Features and Benefits** on the next page for a more complete list of options.



Seated position



Tilted position



AmbiTask Light Combo

Electronically height adjustable and retractable monitor platform on telescopic drives for 3 LCD monitors

Deluxe Ergo Tier Cart™ 72"W x 36"D

Electronic Adjustment:

- SURFACE HEIGHT
- SURFACE TILT
- MONITOR HEIGHT
- FOCAL LENGTH

Features and Benefits

- Electronic adjustment of work surface height and tilt
- Electronic adjustment of monitor height and focal length (forward/backward motion)
- Cold-rolled 11-gauge steel frame with epoxy-powder-coated finish
- Particle-board-core top with your choice of high-pressure laminate finish edged with bumper molding
- Multiple colors available (for standard colors, see page 103)
- Four-inch casters (two of them locking)
- Glides and additional accessories available (see page 92)

Specifications

- Work surface width: 60", 72", 84", 96"
- Work surface depth: 34", 36"
- Height from the floor:
 - Work surface: 28" to 47"
 - Monitors: 38" to 57"
- Custom sizes available

Optional

- Metal privacy partition affixed to the workstation, with or without acoustical material
- Advanced warm/cool air environmental control system regulated at the workstation (for tables 84" wide and up)
- Digital readout of monitor height and focal length, with memory settings
- Monitor bracket supporting up to 50 lbs
- Adjustable ambient LED backlighting with dimmer switch
- Pop-up data ports and a built-in USB hub embedded in the work surface
- Full or split bottom shelves

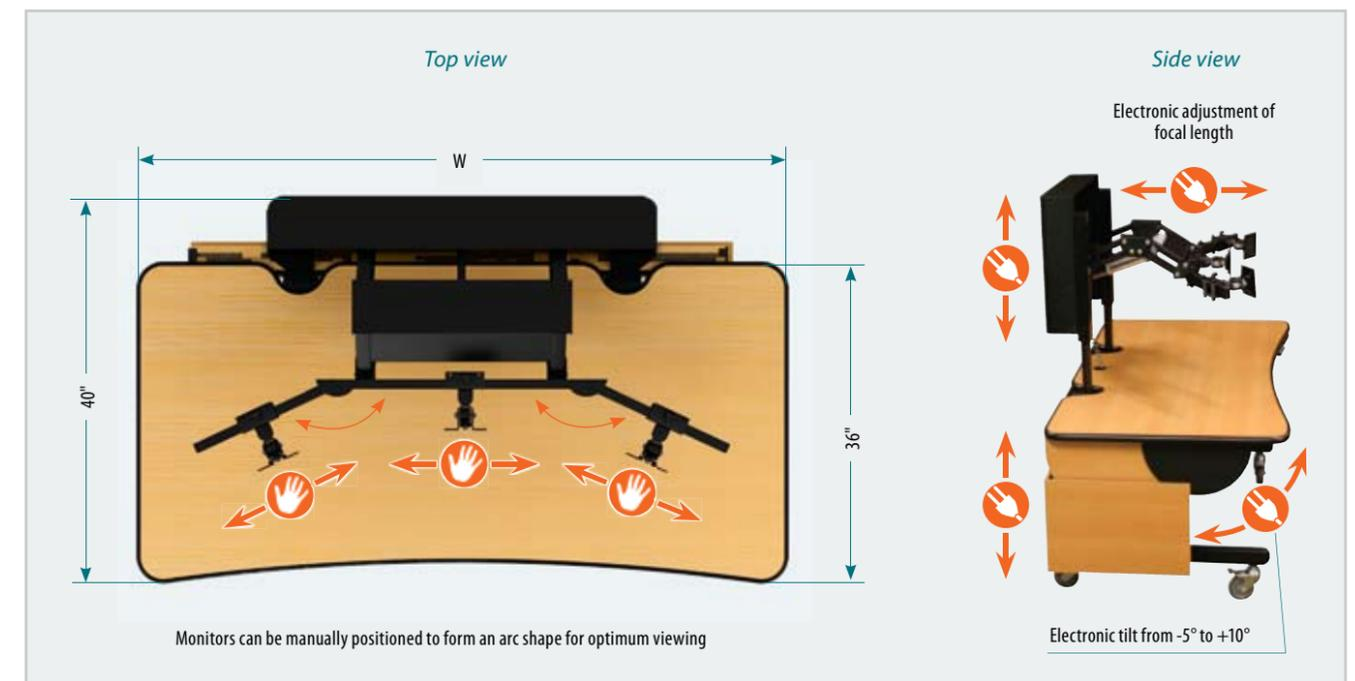

Monitors can be manually positioned to form an arc shape for optimum viewing

Electronic tilt from -5° to +10°



Our *AmbiTask Light Combo* can be controlled with independent dimmer switches for total operator management of workstation lighting



A. Deluxe Ergo Tier Cart™
72"W x 36"D:

- Electronically height adjustable and retractable monitor platform on telescopic drives for three LCD monitors # AFCERGO03
- Adjustable Phone Arm # TA002
- Ergonomic Foot Rest # FR002

B. Deluxe Ergo Tier Cart™
72"W x 50"D:

- Custom work surface shape
- Electronically height adjustable and retractable monitor platform on telescopic drives for four LCD monitors # AFCERGO04
- Two clamp-mount Monitor Arms # AFCFLEXOARM
- AmbiTask Light Combo # AMBL001
- LED Task Light # TAL400
- Adjustable Phone Arm # TA002
- Two mobile CPU cradles # CPU-02
- Two Wire Managers # WMF200

C. Deluxe Ergo Tier Cart™
96"W x 36"D:

- Electronically height adjustable and retractable monitor platform on telescopic drives for four LCD monitors # AFCERGO04
- Swinglift Keyboard Arm # KA7001 with Custom Tray
- AmbiTask Light Combo # AMBL001
- Adjustable Phone Arm # TA002

Ergo Tier Cart™

The **Ergo Tier Cart™** includes numerous features that empower radiologists and healthcare professionals to optimize their reading environment. The workstation has independent, electronic height adjustment of the work surface and monitor platform. The monitors can be retracted toward and away from the user, either manually or electronically.

The **Ergo Tier Cart™** is available with a full range of accessories to insure comfort and convenience. Cable management keeps wires neat

and unobtrusive, while dimmer-controlled task lighting illuminates the work surface at the desired intensity, reducing eye strain and glare. Adjustable phone and dictation arms keep the equipment within reach, while leaving work surfaces clutter-free.

Other useful features include CPU/UPS holders, a sturdy footrest to ease back strain, and even a metal cup holder positioned to avoid spills. Four-inch locking casters facilitate easy movement.

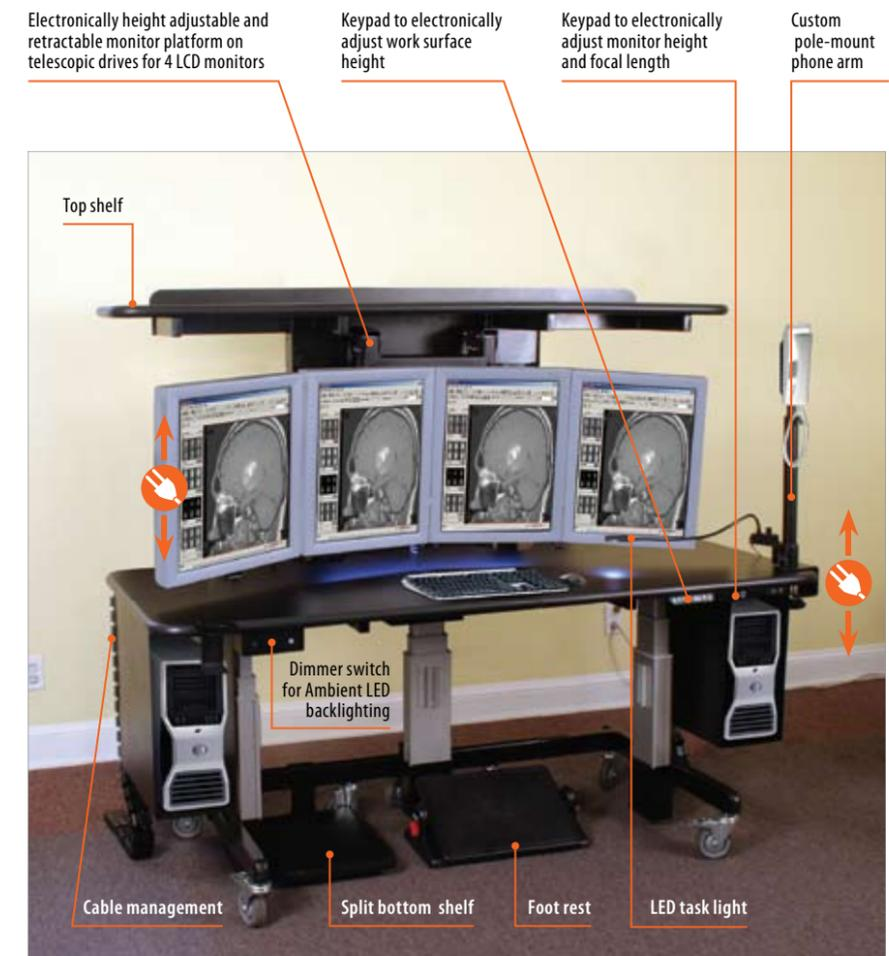
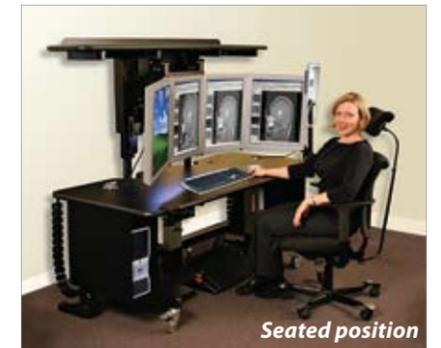

Ergo Tier Cart™ EFX 72"W x 36"D
(top shelf and accessories are optional)



Electronic Adjustment:

- SURFACE HEIGHT
- SURFACE TILT
- MONITOR HEIGHT
- FOCAL LENGTH (optional)

Features and Benefits

- Electronic adjustment of work surface height
- Electronic adjustment of monitor platform height
- Electronic or manual adjustment of monitor platform focal length (forward/backward motion)
- Cold-rolled 11-gauge steel frame with epoxy-powder-coated finish
- Particle-board-core top with your choice of high-pressure laminate finish edged with bumper molding or T-molding
- Multiple colors available (for standard colors, see page 103)
- Four-inch casters (two of them locking)
- Glides and additional accessories available (see page 92)

Specifications

- Width: 48", 60", 72", 84", 96"
- Depth: 30", 34", 36"
- Height from the floor:
 - Work surface: 28" to 47"
 - Monitors: 38" to 57"

Optional

- Metal privacy partition affixed to the workstation, with or without acoustical material
- Advanced warm/cool air environmental control system regulated at the workstation (for tables 84" wide and up)
- Digital readout of monitor height and focal length, with memory settings
- Monitor bracket supporting up to 50 lbs
- Adjustable ambient LED backlighting with dimmer switch (see photo on page 9)
- Pop-up data ports and a built-in USB hub embedded in the work surface
- Wire manager
- Top shelf
- Full or split bottom shelves

Work Surface Shapes¹

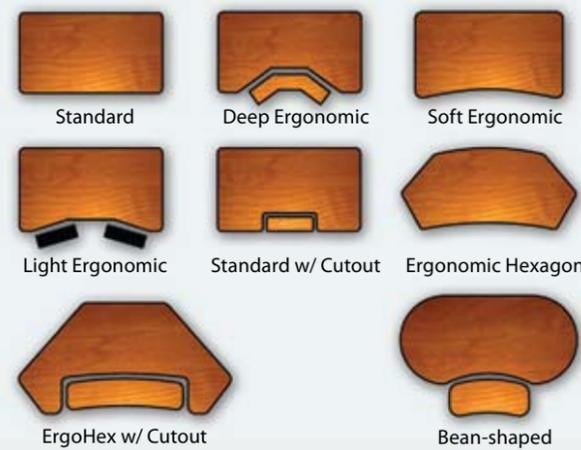

¹ Availability of shape depends on size of the cart

Molding



The round edges of your desk reduce pressure on the palm side of your wrist

EFX Series

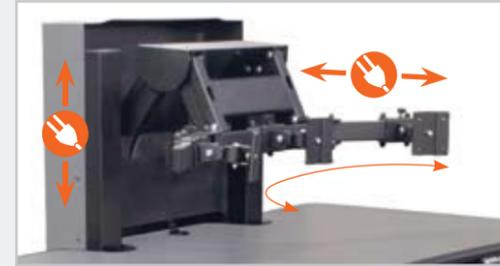

- Electronic adjustment of monitor height
- Electronic adjustment of monitor focal length
- Side wings allow outer monitors to form an arc

FX Series

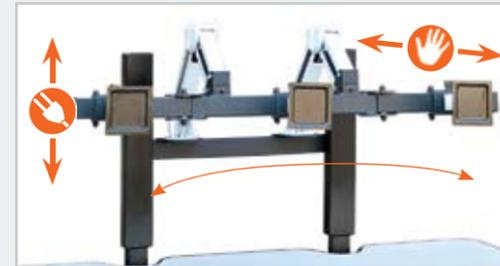

- Electronic adjustment of monitor height
- Manual adjustment of monitor focal length
- Side wings allow outer monitors to form an arc

ZX Series



- Electronic adjustment of monitor height
- Manual adjustment of each monitor focal length
- Horizontal sliding of each monitor on the track

RX Series

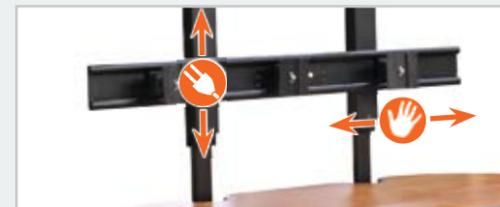

- Electronic adjustment of monitor height
- Horizontal sliding of each monitor on the track
- Option: extended monitor arms # AFC18 at both ends provide comfortable parabolic viewing shape

Electronically Adjustable Monitor Platforms

You can combine one of our electronically adjustable monitor platforms shown on the left with any work surface shape from pages 14 and 15.

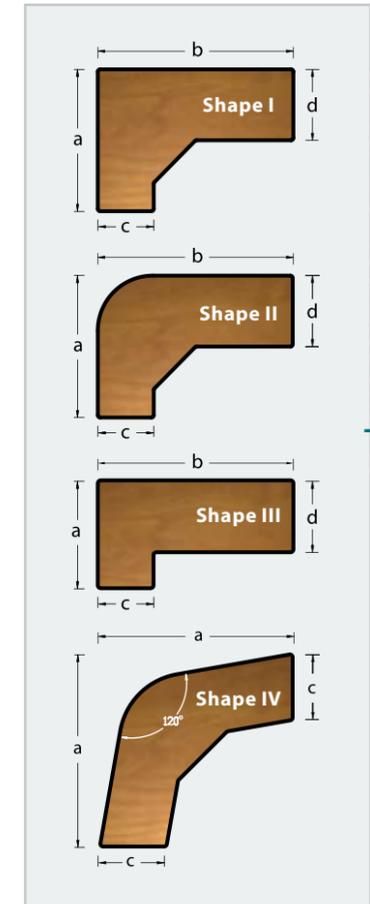

Corner Work Surface Shapes¹

¹ Availability of shape depends on size of the cart

Ergo Tier Corner Cart™ Specifications

Overall work surface width	a	48", 60", 72", 84", 96"
	b	48", 60", 72", 84", 96"
Work surface depth	c	24", 30", 36"
	d	24", 30", 36"
Height of work surface from the floor		28" to 47"

**A. Ergo Tier Cart™
60"W x 34"D with FX
Monitor Platform:**

- Soft Ergonomic work surface shape
- LCD Monitor Arms on telescopic drives # AFCERGO03
- Clamp-mount task light # TAL200A with dimmer
- Adjustable Phone Arm # TA002
- Adjustable Dictation Arm # TA003B
- Clamp-mount metal Cup Holder # MCH-100
- Wire manager # WMF100
- Full bottom shelf
- Foot Rest # FR010



Full bottom shelf

**B. Ergo Tier Cart™
84"W x 34"D with ZX
Monitor Platform:**

- Soft Ergonomic work surface shape
- Z-series Monitor Arms on telescopic drives # AFCERGO05_Z
- Clamp-mount metal Cup Holder # MCH-100
- Two split bottom shelves



Two split bottom shelves

**C. Ergo Tier Cart™
60"W x 36"D with ZX
Monitor Platform:**

- Soft Ergonomic work surface shape
- Z-series Monitor Arms on telescopic drives # AFCERGO03_Z
- Acoustical privacy partition
- Clamp-mount task light # TAL200A with dimmer
- Mobile CPU cradle # CPU-02
- Two wire managers # WMF100



**D. Ergo Tier Cart™
72"W x 84"W x 30"D x 30"D
with FX Monitor Platform:**

- Corner work surface Shape I
- LCD Monitor Arm on telescopic drives # AFCERGO04
- Keyboard Arm # KA6000
- Keyboard Tray # TR2000 with sliding mouse tray
- Adjustable Phone Arm # TA002
- Dictation Arm # TA003B
- Bottom shelf



**E. Ergo Tier Cart™
84"W x 84"W x 34"D x 34"D
with two FX Monitor
Platforms:**

- Corner work surface Shape III
- Two sets of LCD Monitor Arms on telescopic drives # AFCERGO03 and # AFCERGO04
- Two adjustable CPU Holders # CPU 13-25
- Bottom shelf

**F. The JW Treadmill Desk™
83"W x 56"W x 21"D x 21"D
with FX Monitor Platform:**

- AFC Industries, with feedback from our customers, designed this ergonomic console that accommodates a variety of exercise devices, like treadmills, exercise bikes, or a stair stepper.
- Custom work surface shape
 - LCD Monitor Arms on telescopic drives # AFCERGO05



Bottom Workstation Options

Dual Tier Cart™

The **Dual Tier Cart™** is ideal for professionals who require two independently adjustable surfaces to perform their tasks. At the touch of a button, the **Dual Tier™** lets you adjust the height of the monitors and work surfaces from a seated to a standing position.

In its bifocal position, the monitors are lower than the work surface, ensuring a comfortable viewing angle. This flexibility delivers optimum body positioning and comfort.

Why adjust yourself to your workstation when the **Dual Tier Cart™** adjusts to you?

Electronic Adjustment:

- TIER 1 HEIGHT
- TIER 2 HEIGHT

Features and Benefits

- Independent electronic height adjustment of both tiers
- Customized ergonomic work surfaces available
- Cold-rolled 11-gauge steel frame with epoxy-powder-coated finish
- Particle-board-core top with your choice of high-pressure laminate finish edged with bumper molding
- Multiple colors available (for standard colors, see page 103)
- Four-inch casters (two of them locking)
- Glides and additional accessories available (see page 92)

Optional

- Digital readout of tier 2 height
- Advanced warm/cool air environmental control system regulated at the workstation
- Pop-up data ports and a built-in USB hub embedded in the work surface
- Top shelf
- Full or split bottom shelves
- Modesty panel
- Partitions with removable lower metal panel for back CPU access and continuous cable management



Our partitions absorb sound and provide privacy as well as prevent interference from monitors or other light sources

Complete your desk with any of our Desktop or Z-Series Monitor Arms (see pages 96 and 97 for more accessories)

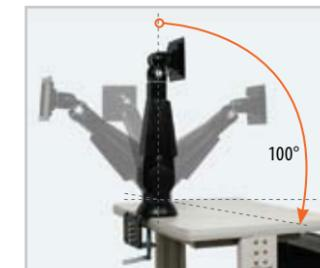

Monitor Arm # AFC02 features:

- Tilt range — from -10° to 90°
- Joint swivels — from -90° to 90°



Monitor Arm # AFCZ588-03 features:

- Pivot upwards & downwards
- Joint swivels — from -90° to 90°



Z-series monitor arms mounted on the track benefits:

- Every Z-arm slides left-right on the rail, plus the freedom motion of the extension allows precise positioning of the monitors and the distance of the LCD to you
- Full extension of each arm — 20"

Work Surface Shapes¹

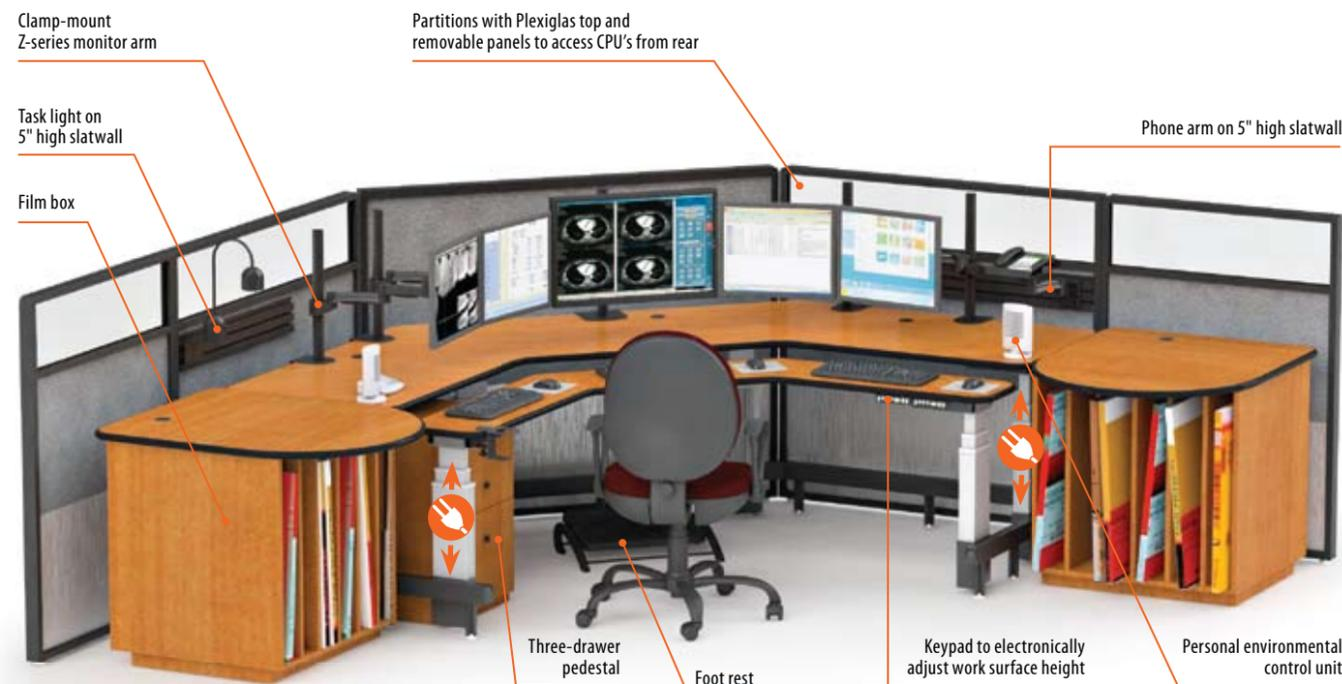
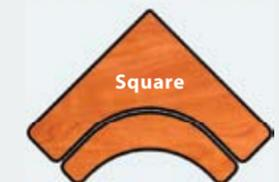
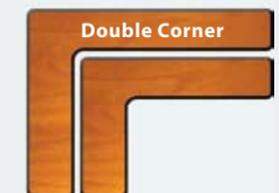

Dual Tier Cart™ Specifications

Work surface shape	Standard	Banana Corner	Corner	Double Corner	Hexagon	Diamond
Total width	48", 60", 72", 84", 96"	64", 72"	48", 60", 72", 84", 96"	72", 84"	90"	72", 84"
Total depth	32", 36", 40"	64", 72"	68" - 112"	72", 84"	38"	36"
Back tier depth	16", 20", 24"	16"	16", 20", 24"	16", 18"	18"	13"
Front tier depth	16", 18"	16"	12", 16"	16", 18"	18"	18"
Return depth	—	—	18", 24"	16", 18"	—	—
Front tier overall depth	—	—	48", 60", 72", 84"	—	—	—

Height of work surface from the floor ranges from 28" to 47"

Corner Dual Tier Cart™ 136"W x 62"D with two film boxes and three-drawer pedestal

¹ Availability of shape depends on size of the cart

A. Dual Tier Cart™
60"W x 36"D:

- Standard work surface shape
- Two clamp-mount Monitor Arms # AFCFLEXOARM
- Retractable Keyboard Tray # KB01
- Wire Manager # WMF200
- Mobile storage cabinet



B. Dual Tier Cart™
72"W x 36"D:

- Standard work surface shape
- Z-series Monitor Arms # AFCRAILZ04-3CLAMP
- Two split bottom shelves
- Foot Rest # FR010



C. Dual Tier Cart™
72"W x 44"D:

- Diamond work surface shape
- Three Z-series Monitor Arms # AFCZ500-01
- Leg-mount CPU Holders # CPU-07



D. Dual Tier Cart™
90"W x 38"D:

- Diamond work surface shape
- Three Z-series Monitor Arms # AFCZ500-01
- Modesty panels



The Duet Tier™



The Duet Tier™ for those who need to move from one working position to another. This workstation allows users to sit at one work surface while having the second work surface within reach at a comfortable height. This is ideal for someone who has to scan several pages, or someone working with a microscope in a standing position and sitting at computer without having to adjust the height of entire work surface.

With two electronic surface height controls the Duet Tier™ is suitable for multiple users, at different heights, working on the same task. Dual presentations become easily manageable, with two heights available in one workstation.



Interactive Builder



Configure your own Dual Tier Cart™ at www.afcindustries.com/dualtier



E. Dual Tier Cart™
64"W x 64"D:

- Top shelf
- Banana Corner work surface shape
- Z-series Monitor Arm # AFCZ588-02
- Back modesty panel
- Corner split bottom shelf



F. Dual Tier Cart™
72"W x 72"D:

- Square work surface shape
- Two Z-series Monitor Arms # AFCZ566-02
- Two Wire Managers # WMF100
- Full bottom shelf
- Glides # GLID-ADJ



G. Dual Tier Cart™
72"W x 72"D:

- Double Corner work surface shape
- Three Z-series Monitor Arms # AFCZ588-02
- Two CPU Holders



H. Dual Tier Cart™
93"W x 46"D:

- Half-Moon work surface shape
- Z-series Monitor Arms # AFCZ588-01 and # AFCZ588-02
- Adjustable Dictation Arm # TA003B
- LED Task Light # TAL400
- Three split bottom shelves

Single Tier Cart™

The **Single Tier Cart™** is the perfect choice when different positions are required from a single workstation. With a full range of design options and accessories, the **Single Tier Cart™** is adaptable to any work environment. Electronic height adjustment makes the **Single Tier Cart™** versatile for multiple users.

The cart can be enhanced with cabinetry, shelving, computer storage, lighting and other ancillary equipment.

Electronic Adjustment:

▪ SURFACE HEIGHT

Features and Benefits

- Electronic adjustment of work surface height
- Variety of surface shapes available
- Cold-rolled 11-gauge steel frame with epoxy-powder-coated finish
- Particle-board-core top with your choice of high-pressure laminate finish edged with T-molding/bumper molding
- Multiple colors available (for standard colors, see page 103)
- Four-inch casters (two of them locking)
- Glides and additional accessories available (see page 92)

Specifications

- Width: 36", 48", 60", 72", 84", 96"
- Depth: 24", 30", 36"
- Height of work surface from the floor: 28" to 47"
- Custom sizes available

Optional

- Metal privacy partition affixed to the workstation, with or without acoustical material
- Monitor bracket supporting up to 50 lbs
- Pop-up data ports and a built-in USB hub embedded in the work surface
- Wire manager
- Full or split bottom shelves

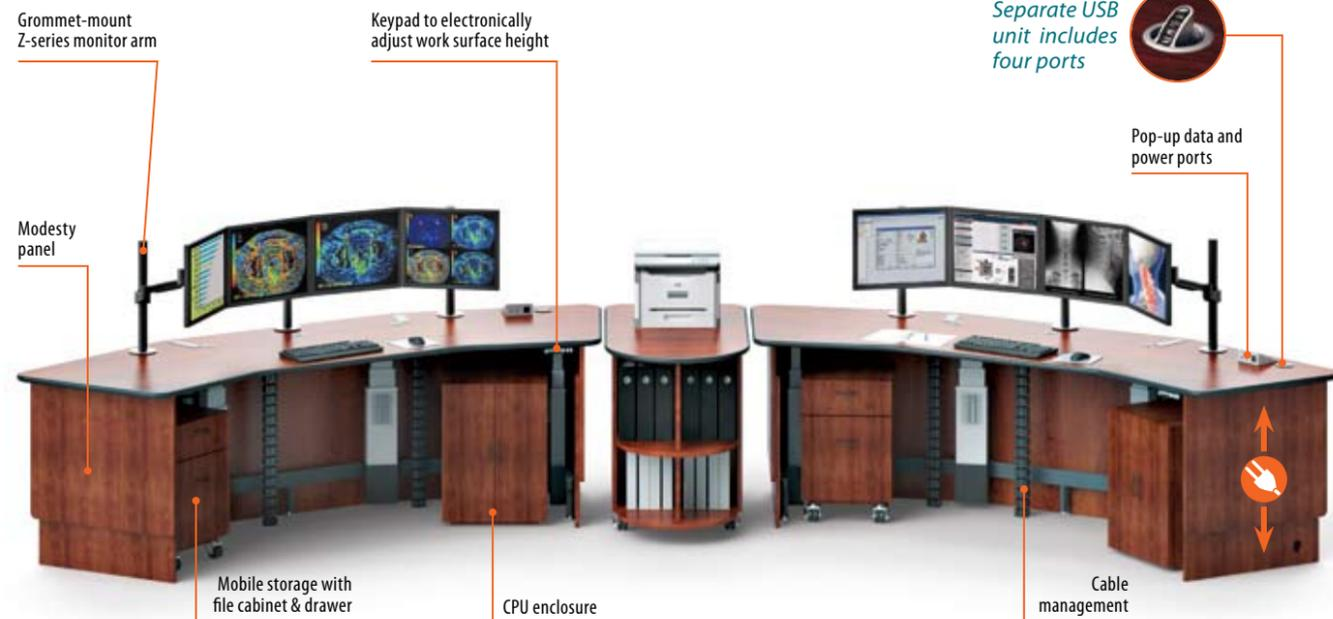

Single Tier Corner Cart™ 108"W x 30"D (modesty panel and accessories are optional)

Work Surface Shapes

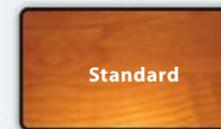

Standard

for all widths



Standard w/ cutout

for tables 48" wide and up



Soft Ergonomic

for all widths



Light Ergonomic

for tables 60" wide and up

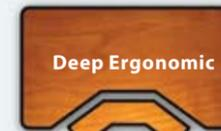

Deep Ergonomic

for tables 48" wide and up



Bean-shaped

for tables 48" wide and up



Ergonomic Hexagon

for tables 60" wide and up



ErgoHex w/ Cutout

for tables 72" wide and up



A. Single Tier Cart™ 36"W x 24"D:

- Standard work surface shape
- Keyboard Arm # KA6000
- Keyboard Tray # TR2000 with sliding mouse tray
- Bottom shelf

B. Custom Single Tier Cart™ 36"W x 30"D:

- Soft Ergonomic work surface shape
- Clamp-mount Monitor Arms # AFC02
- Pencil Drawer # PD002
- Retractable File Holder
- CPU Holder # CPU-01
- Back modesty panel

C. Single Tier Cart™ 48"W x 24"D:

- Top shelf
- Standard work surface shape
- Keyboard Arm # KA6000
- Custom Keyboard Tray
- CPU Holder # CPU-01
- Back modesty panel
- Handle
- Full bottom shelf

D. Single Tier Cart™ 66"W x 33"D:

- Bean-shaped work surface
- Z-series Monitor Arm # AFCZ588-05
- Phone Arm # TA002
- Keyboard Arm # KA6000
- Keyboard Tray # TR2000 with sliding mouse tray
- Two adjustable CPU Holders # CPU 13-25
- Pop-up data ports # DPA-01
- Wire Manager # WMF100
- Metal Cup Holder with clamp # MCH-100

E. Single Tier Cart™
72"W x 30"D:

- Clipboard holder # CLPHLD
- Bean-shaped work surface
- Z-series Monitor Arm # AFCZ588-02
- Two Keyboard Arms # KA6000
- Two Keyboard Trays # TR2000 with sliding mouse tray
- Full bottom shelf



Interactive Builder



Configure your own Single Tier Cart™ at www.afcindustries.com/singletier

H. Single Tier Cart™
116"W x 30"D:

- Custom work surface shape
- Four Z-series Monitor Arms # AFCZ588-01
- 10" high slatwall
- Swinglift Keyboard Arm # KA7001 with custom tray
- Two lockable cabinets with front and rear hinged doors
- Two round work surface extensions
- Modesty panels



F. Single Tier Cart™
60"W x 30"D:

- Ergonomic Hexagon work surface shape
- Z-series Monitor Arm # AFCZ588-02
- Adjustable CPU Holders # CPU 13-25



G. Single Tier Cart™
96"W x 36"D:

- Standard w/ Cutout work surface shape
- Z-series Arms # AFCZ588-02 and # AFCZ588-03
- AmbiTask Light Combo # AMBL001
- Swinglift keyboard arm
- Partition with removable lower metal panel for back CPU access
- CPU enclosure with mobile platform



Mobile CPU enclosure allows for both front and back CPU access

Find below more solutions to complete your workstation with our ancillary equipment



Z-series Monitor Arm # AFCZ588-02



Z-series Monitor Arm # AFCZ588-02V



The Slatwall is a great way for a multitude of accessories that can easily be maneuvered to create an unlimited number of combinations



Our Articulating Arm # AFCFLEXO_5 provides manual adjustment of monitor focal length while side wings allow outer monitors to form an arc for maximum monitor reading comfort

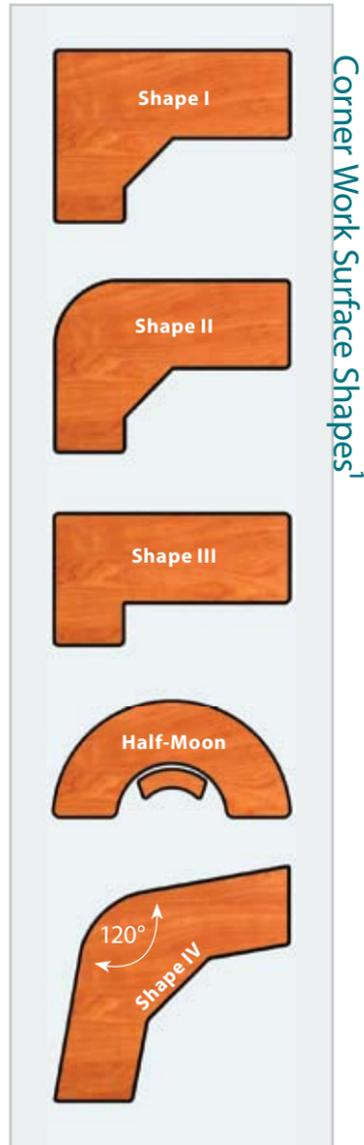

¹ Availability of shape depends on size of the cart

Single Tier Corner Cart™ Specifications	
Overall work surface width	48", 60", 72", 84", 96"
	48", 60", 72", 84", 96"
Work surface depth	18", 24", 30", 36"
	18", 24", 30", 36"
Height of work surface from the floor	28" to 47"

A modification of the **Single Tier Cart™**, this handsome design is just right for maximizing your workspace in executive suites and welcome areas. Ergonomically designed work surface complements electronic height adjustment, enhancing the functionality and versatility of this **Single Tier Corner Cart™**. The workstation features two Z-series monitor arms mounted on the horizontal tracks, allowing you to position the monitors at any viewing level, angle, and depth.



Two Z-arms # AFCZ568 mounted on the vertical tracks allow you to position the monitors at any viewing level, angle, and depth from the viewer

Digital readout of surface height with four memory presets



I. Single Tier Corner Cart™
84"W x 90"W x 36"D x 30"D
with modesty panels and glass

Top Workstation Options



J. Single Tier Corner Cart™
56"W x 54"W x 30"D x 24"D:

- Clipboard Holder # WCH-100
- Corner work surface Shape III
- Phone Arm # TA002
- Retractable Pencil Drawer # PD002
- CPU Holder # CPU-01
- Partition
- Fluorescent Under-Shelf Light 18" wide # TAL300F
- Glides # GLID-ADJ

K. Single Tier Corner Cart™
72"W x 48"W x 30"D x 30"D:

- Flipper cabinet with three doors # FC
- Corner work surface Shape I
- Three clamp-mount Monitor Arms # AFC02
- Keyboard Arm # KA6000
- Keyboard Tray # TR3000
- Retractable Writing Platform # RWP-900
- Split bottom shelf

L. Single Tier Corner Cart™
72"W x 60"W x 24"D x 24"D:

- Top Shelf
- Corner work surface Shape III
- Two clamp-mount Monitor Arms # AFC02
- Keyboard Arm # KA6000
- Keyboard Tray # TR2000 with sliding mouse tray
- Bottom shelf



Optimizing your mobile computing needs

Today's advancing technological world demands what we at AFC refer to as "Whenever ⇔ Wherever" access to data, including electronic medical records, radiology images, and more. The need has become ubiquitous, throughout all areas of healthcare facilities and professional functions — from radiology reading rooms to patient bed-sides, operating rooms to conference rooms; in oncology, cardiology, nuclear medicine, labor and delivery, and more. AFC's array of durable mobile carts are designed to meet this growing need, while incorporating ergonomic features that make them adaptable to any user.

Our height adjustable units are available in footprints as small as 19 inches for easy maneuvering in tight places. Security features protect both sensitive patient information and computer equipment. Our carts are built from materials for thorough disinfection. Long-lasting batteries can be loaded so that carts can move from area to area without being connected to electrical outlets providing uninterrupted power to your workstation wherever and whenever you need it.

Whatever your need is, AFC can build a mobile cart solution for you.

PC Cart™

The PC (Point-of-Care) Carts™ designed for maximum flexibility and streamlined movement. They combine enhanced functionality with the hallmark durability and ergonomic design of AFC's mobile workstations. Our PC Carts™ enable physicians to bring advanced computer technology to the bedside, operating room and any other location where patients will benefit from today's medical computer applications.

The PC Carts™ feature a low profile, small footprint, pneumatic (optional electronic) height adjustment, and support all-in-one computers as well as separate thin client and monitor. For maximum portability, the carts can accommodate a battery power source (see page 32 for power supply options). Select from our range of monitor arms, CPU holders, keyboard trays and other accessories to complete your configuration.



PC Cart™ 910



PC Cart™ 900



PC Cart™ 800



PC Cart™ 500

Features and Benefits

- Sit-to-stand pneumatic height adjustment
- Thorough disinfection for clean room use
- Supports all-in-one computers as well as separate thin client and monitor
- Mounting for all-in-one computer or standard monitor VESA (75/100)
- Rounded phenolic, HDPE¹, laminate, or metal work surface
- Seamless integration of handles into the work surface for easy grip from any user position
- 5" casters with round tread wheels or 4" twin casters

Optional

- Electronic height adjustment
- Keyless electronic lock for utility drawer and divider to facilitate administration of care in two-patient rooms
- Phenolic retractable keyboard tray with ergonomic negative and positive tilt and swivel
- Power supply, wire manager, mouse holder, wire basket, scanner holder, and additional accessories available (see page 92)
- Anti-microbial finish (see inside back cover for more information)

¹ High-density polyethylene (see inside back cover for more information)

PC Cart™ 910

The PC Cart™ 910 combines a streamlined look and enhanced functionality with the hallmark durability and ergonomic design of AFC's mobile work stations.

With an all-in-one computer, the height-adjustable PC 910 offers a battery that can run for up to 25 hours before recharging. UL 60601-1 compliant, it is safe to use throughout facilities. Fleet management software allows for IT monitoring, management, and programming of carts for location, battery status, and scheduling of computer shutdown, recharging and maintenance.

A phenolic/HDPE work surface with rounded corners enhances safety and appeal. Cutout handles on all corners facilitate grip, access from any user position, and range of motion. The retractable phenolic keyboard tray features ergonomic tilt, swivel, and a sliding mouse tray for both left- and right-handed users.



A. PC Cart™ 910



PC Cart™ 910 in emergency room



B. PC Cart™ 910

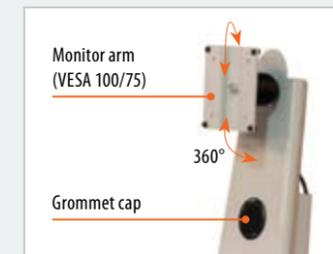

Mounting for all-in-one computer or standard monitor (VESA 100/75)

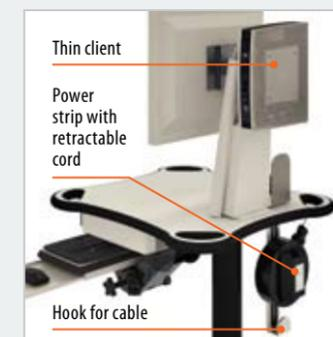

Supports separate thin client and monitor



Utility drawer with keyless electronic lock and divider



Specifications

- Pneumatic height adjustment
- Rounded phenolic/HDPE work surface for greater safety, comfort, and appeal
- Seamless integration of handles into the work surface on all four corners for easy grip from any user position
- Keyless electronic lock for utility drawer and divider to facilitate administration of care in two-patient rooms
- Phenolic retractable keyboard tray with ergonomic negative and positive tilt and swivel
- Mouse tray slides to accommodate left- and right-handed users
- 5" casters with round tread wheels for ease of movement
- Footprint size: 20"W x 24"D
- Work surface size: 24"W x 24"D
- Keyboard tray size: 19"W x 8"D
- Height of work surface from the floor: ~30" to 42"

Standard Colors

- Putty
- Gray
- Black

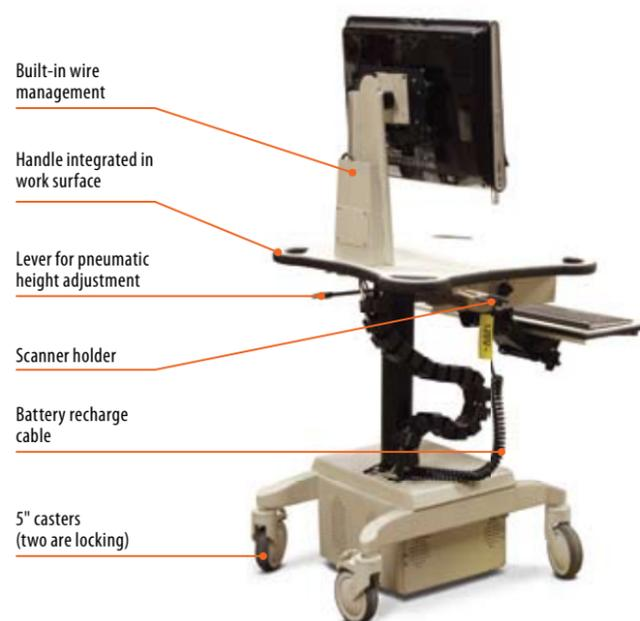

PC Cart™ 910 (back view)

Carts for telemedicine application



C. Telemedicine Cart TMC300 with camera shelf on Z-arm



D. Telemedicine Cart XPC1926 with two pneumatically height-adjustable drives and camera shelf on Z-arm

POWER SUPPLY OPTIONS

Hot Swappable Mobile Power Systems



Features and Benefits

- **Cycle-Life:** Replace batteries in YEARS not months
- **Uninterrupted Operation:** Simultaneously powered technology while the batteries charge
- **Fast charging:** Within 2 hours while the technology is in use
- **Lighter:** Significant weight reduction
- **Runtime:** Entire shift or longer
- **Easy access:** Changes and upgrades are easy to complete
- Virtually Maintenance Free

Battery Specifications

- **Size:** 3.75" x 5.25" x 4" (9.53 cm x 13.34 cm x 10.16 cm)
- **Weight:** 3.4 lbs (1.5 kg)
- 14.4 V 160 Wh Li-Ion battery
- Military grade cell technology
- Integral digital features
- REAL-TIME display
- Meets regulatory requirements including CE

How it works:

Two of the batteries are mounted to the cart while two others are being charged. Once the two on the cart are depleted, the user swaps them out for fresh ones.

Runtime:

The cart would have about 360 Wh of available power. Once you calculate your wattage draw, divide the number by available power to get your runtime.

Charging:

Typical charge time is 3.5 hours to 85% and 4 hours to 100%.

LiFe (Lithium Iron Battery)

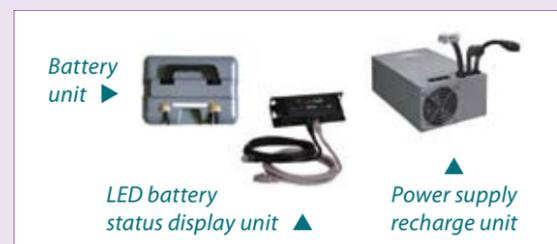

Features and Benefits

- UL 60601-1 compliant for safe use in all patient and non-patient areas
- Power alert software protects data and low-battery alarm can be muted
- IT Fleet management software for monitoring, programming, and management of PC 910s throughout a facility
- LED monitoring of battery status
- Advanced 3-stage charger accelerates recharging and increases safety
- Internal Automatic Transfer Switch allows power supply to run connected equipment while battery module is recharging

Sealed Lead Acid Battery



We offer a **Power Supply Unit** with three main components:

Power Supply/Recharger (remains the same for any size battery) recharges the battery that it is connected to. The cart has three AC power outlets to which the user can plug in their monitor and CPU.

LED-Battery-Status Display shows amount of power in battery, alerting user to recharge battery by connecting to Power Supply/Recharger. The unit is generally attached to the monitor arm or in a visible location of the cart.

Battery available in three sizes, each determines run time (~4.3 hours, ~6.5 hours, and ~10 hours).

PC Cart™ 900

For high-traffic areas where the width and height of the base are crucial, especially between patient beds or medical equipment, AFC offers the **PC Cart™ 900**.

Available with an optional scanner holder and additional accessories, the **PC Cart™ 900** can easily adapt to all work situations. It's sleek, yet durable, quad-point base has a small footprint and an overall height of less than 6" from the floor.



Specifications

- Pneumatic height adjustment
- Rounded phenolic/HDPE work surface
- Seamless integration of handles into the work surface on all four corners for easy grip from any user position
- Phenolic retractable keyboard tray with ergonomic negative and positive tilt and swivel
- Mouse tray slides to accommodate left- and right-handed users
- Work surface size: 24"W x 24"D
- Keyboard tray size: 19"W x 8"D
- Footprint size: 18"W x 18"D
- 4" twin casters
- Height of work surface from the floor: ~30" to 42"

Optional

- Keyless electronic lock for utility drawer and divider to facilitate administration of care in two-patient rooms
- Phenolic retractable keyboard tray with ergonomic negative and positive tilt and swivel
- CPU holder, mouse and scanner holders, and additional accessories available (see page 92)

Available Colors

- Putty
- Gray
- Black



A. PC Cart™ 900

- Rounded phenolic work surface with four built-in handles
- VESA (75/100) monitor arm
- Retractable keyboard tray with sliding mouse tray
- Mouse holder # M001
- Base-mount CPU holder # CPU-99



B. PC Cart™ 900

- Rounded HDPE work surface with four built-in handles
- VESA (75/100) monitor arm
- Thin client
- Utility drawer with electronic lock
- Retractable keyboard tray with sliding mouse tray
- Mouse holder # M001
- Scanner holder # S01

PC Cart™ 800

This multi-purpose and functional cart is ideal for all healthcare business and service sectors. The PC Cart™ 800 has laminate, phenolic, or HDPE work surface and a rectangular base of 19"W x 20"D. This mobile computer cart features a pneumatic sit-to-stand or user-to-user height adjustment.

Completely modular. Select from our full range of monitor arms, CPU holders, keyboard trays and other accessories to complete your configuration.

Easily adapted for use with CPUs, tablet PCs or notebook computers, it can also provide video teleconferencing capability with minor add-ons.

Available in several colors to match most color schemes or to stand out for easy identification.



A. PC Cart™ 800

- Laminate work surface
- Clamp-mount monitor arm # AFCZ588-01
- Handle

B. PC Cart™ 800

- Laminate work surface
- Pole-mount Monitor Arms # AFCZ5-00
- Retractable keyboard tray # KB03
- Lockable CPU holder # CPU-09
- Handle

C. PC Cart™ 800

- HDPE work surface with two built-in handles
- Pole-mount Monitor Arms # AFCZ5-00
- Retractable keyboard tray # KB03
- Base-mount CPU holder # CPU-99

PC Cart™ 500

The PC Cart™ 500 is pneumatically height-adjustable to enable computer use while the user is standing or seated. The cart's all-metal body enables disinfection and clean-room use. Our PC Cart™ 500 with power supply brings advanced computer technology to any location. A retractable keyboard tray with sliding mouse tray are included.

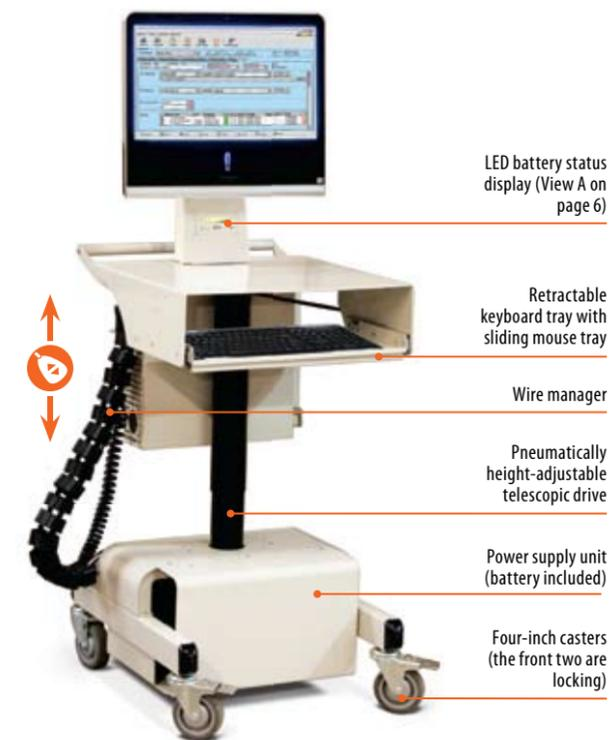
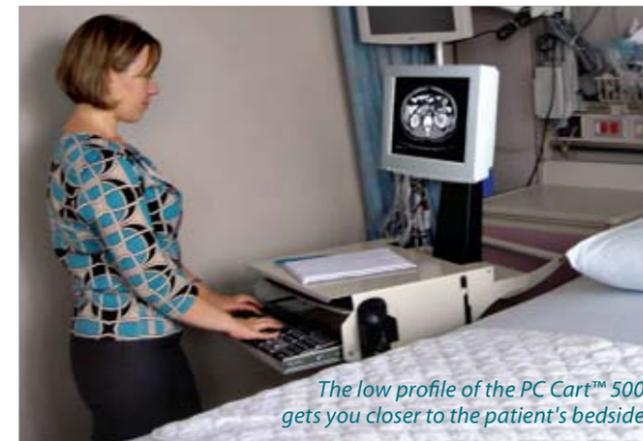

A. PC Cart™ 500 with power supply

Specifications

- Pneumatic or electronic height adjustment
- Built exclusively from cold-rolled steel with epoxy-powder-coated finish
- Work surface size: 20"W x 20"D
- Retractable keyboard tray with slide-out mouse tray (19"W x 8 ½"D)
- Rectangular base size: 20 ½"W x 24"D
- 4" casters
- Height of work surface from the floor: ~30" to 42"
- Additional accessories available (see page 92)

Optional

- Power supply unit with LED monitoring of battery status (see page 30)
- CPU/UPS holder
- Wire manager # WMF200 (to manage cables going from the power supply unit to the LED display)

Available Colors

- Putty
- Gray
- Black
- White

Specifications

- Pneumatic height adjustment
- Laminate/phenolic/HDPE work surface with handles
- Work surface size: 22 ½"W x 20"D
- Footprint size: 19"W x 20"D
- 4" twin casters
- Height of work surface from the floor: ~30" to 42"

Optional

- Seamless integration of handles into the work surface on the corners for easy grip
- Retractable keyboard tray

Laminate Colors

- Putty
- Gray
- Black
- White
- Red
- Green
- Blue

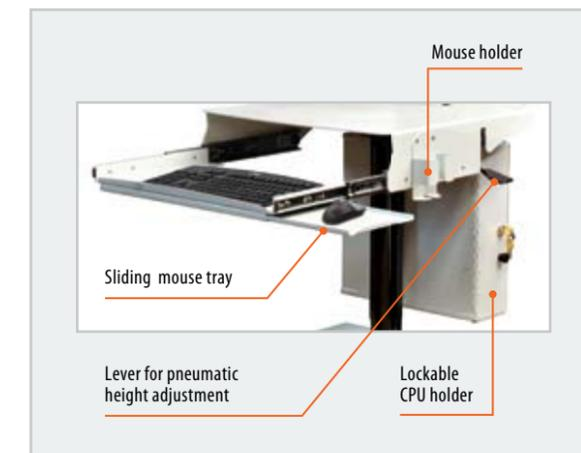

A. PC Cart™ 500 with power supply

Optional Monitor Arms



Twin Monitor Arm
2MH



Z-series Monitor Arm
AFCZ500-01



Grommet-mount Monitor Arm
AFCPOLE

PC Cart™ Accessories



Antiseptic wipe holder



Biohazard waste holder



Wire basket



B. PC Cart™ 500

- LED battery status display
- Retractable keyboard tray with sliding mouse tray
- CPU holder # CPU-09
- Handle

C. PC Cart™ 500

- Twin Monitor Arm # 2MH
- Retractable keyboard tray with sliding mouse tray
- CPU holder # CPU-09
- Mouse holder # M001
- Handle

D. PC Cart™ 500

- Grommet-mount Monitor Arm # AFCPOLE
- Locking drawer
- LED battery status display
- Retractable keyboard tray with sliding mouse tray
- Wire basket # WB-100
- Mouse holder # M001
- Handle

E. Custom PC Cart™ (fixed height)

- Locking drawer
- Retractable keyboard tray with sliding mouse tray
- Handle
- Six utility hooks
- Two base-mount CPU Holders # CPU-99
- Back modesty panel
- Locking enclosure fixed on the bottom shelf

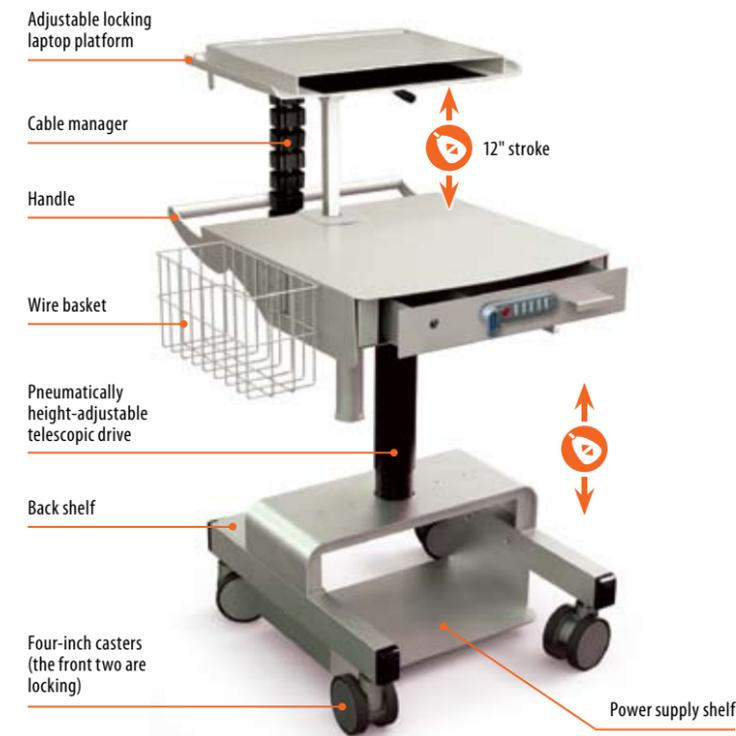

F. Dual PC Cart™ 500 with utility drawer

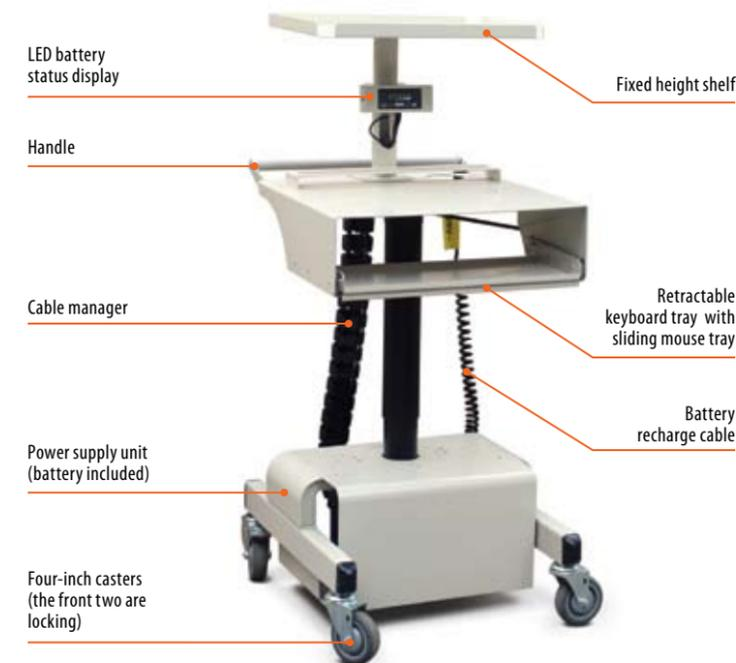

G. Dual PC Cart™ 500 with power supply

The PC Cart™ 500 also comes in Dual and Deluxe configurations. The Dual PC Cart™ 500 allows for independent movement of two surfaces. The upper surface can be used as a laptop platform. The Deluxe PC Cart™ 500 features electronic height adjustment (see next page).



Laptop platform with pneumatic height adjustment



Utility drawer with electronic lock

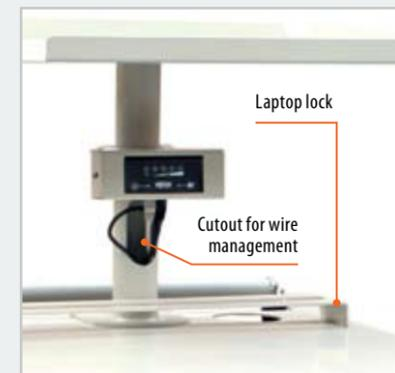

LED battery status display

Electronic Adjustment:

▪ SURFACE HEIGHT



H. Deluxe PC Cart™ 500 for one LCD monitor



I. Deluxe PC Cart™ 500 for two LCD monitors



J. Deluxe PC Cart™ 500 with power supply

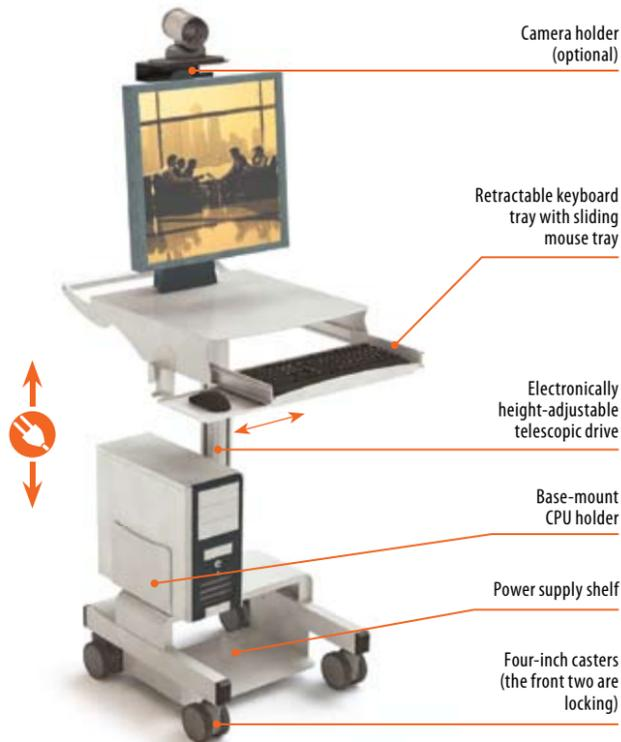

K. Deluxe PC Cart™ 500 with camera holder

Laptop and Tablet Carts

Laptop Carts LPC700/LPC750

Mobile carts have become commonplace throughout hospitals and workplaces, from admissions and operating rooms to patient and conference rooms.

Our multi-functional and highly adaptable carts LPC700 and LPC750 are designed to hold laptops and are ideal for use in any space limited location. The carts feature pneumatic height adjustments and offer a compact look, with a small footprint and a base height of less than 6 inches making them suitable for small work areas. It's specially designed star-shaped base with 3-inch wheels delivers smooth and fluid mobility.



A. Laptop Cart LPC700



Lever for pneumatic height adjustment

Hook for cable



Lockable laptop cover



Power strip with retractable cord

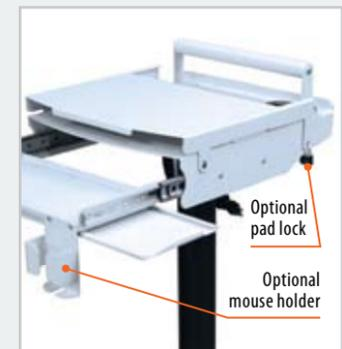

Optional pad lock

Optional mouse holder

Laptop cover lifts and locks with the pad lock

Features & Benefits

- All-metal/HDPE body enables disinfections and clean room use
- Built exclusively from cold-rolled steel with epoxy-powder-coated finish
- Pneumatic height adjustment
- Retractable keyboard tray with sliding mouse tray
- Additional accessories available (see page 92)

Specifications

- Work surface size:
18"W x 16"D (LPC700)
21"W x 12"D (LPC750)
- Height of work surface from the floor:
28" to 44" (+/-2 inch)
- Keyboard tray size:
16"W x 6"D (LPC700)
18"W x 8 1/2"D (LPC750)
- Footprint:
22" star-shaped base
- 3" wheels (the front two are locking)

Optional

- Lockable laptop cover
- Retractable power cord
- Hook for cable

Available Colors

- Putty
- Gray
- Black
- White



AFC Industries introduces the latest addition to its series of laptop carts — the lockable **LPC750** cart. Our newest entry is an ergonomically designed, height-adjustable laptop cart that delivers point-of-care technology improving workflow, increasing accuracy and providing wherever and whenever access to data.

Utilizing one of our smallest footprints, this unit has many features found only in larger more expensive models: integrated handles in the front and sides for ease of maneuverability; pneumatic sit to stand height adjustment; secure lockable laptop platform; retractable keyboard tray with left or right mouse tray; storage bins, a wire basket, a power strip with a hospital grade plug and more.

These units are ideally suited for the medical industry and "clean rooms" as the major contact surfaces are made with anti-microbial materials with smooth contoured surfaces which can be easily cleaned and disinfected.



12" wide cable wrap holder



14"W x 0.25"D recess for pens



B. Laptop Cart LPC750

Laptop Cart LPC200

Our laptop cart # **LPC200** has Integrated handles on the front and rear for ease of maneuverability. All major contact surfaces are made with antimicrobial material with smooth and contoured surfaces. Sliding mouse tray accommodates left and right hand users. An additional base weight increases stability of the laptop cart. We offer multiple color combinations for easy identification and to match the surrounding decor.

Optional Hot Swappable Power Supply provides uninterrupted power to your workstation wherever and whenever you need it. Simply swap out the drained battery from the cart for a fully recharged battery (takes no time at all) from the recharging station for continuous workflow.



Features and Benefits

- Thorough disinfection for clean room use
- Built exclusively from cold-rolled steel with epoxy-powder-coated finish
- Laminate/phenolic/HDPE work surface
- Pneumatic height adjustment
- Integrated handles on the front and rear
- Right and left sliding mouse tray
- Additional accessories available (see page 92)

Specifications

- Work surface size: 18"W x 25"D
- Height of work surface from the floor: ~28" to 44"
- Footprint: 23" diameter five-prong base
- Five 4" twin casters (the front two are locking)

Optional

- Hot Swappable Power Supply / LiFe (lithium Iron battery) / Sealed Lead Acid battery (see page 32)
- Laptop lock shelf
- Wire basket, mouse/scanner holder, retractable power cord

Laminate Colors

- Putty
- Red
- Gray
- Green
- Black
- Blue
- White



A. Laptop Cart LPC200 with laptop lock shelf



Built-in handles on the front and rear for ease of maneuverability



Easy-to-see battery gauge mounted in clear sight makes assessing battery status a snap



Swappable batteries exchange easily and are positioned at an optimal work height to eliminate bending or squatting

Laptop Cart LPC100

A. Laptop Cart # LPC100 with wire basket

- Pneumatic height adjustment
- Height of work surface ranges from the floor: 27" to 37"
- Wire basket # WB-100
- Footprint: 23" diameter five-prong base
- Five 4" twin casters (the front two are locking)



B. Laptop Cart # LPC100 with drawer

- Pneumatic height adjustment
- Height of work surface ranges from the floor: 31" to 41"
- Locking drawer
- Handle
- Footprint: 23" diameter five-prong base
- Five 4" twin casters (the front two are locking)



C. Laptop Cart # LPC100 with wood top

- Pneumatic height adjustment
- Height of work surface ranges from the floor: 27" to 37"
- 24"Wx24"D wood top
- Storage space
- Footprint: 23" diameter five-prong base
- Five 4" casters (the front two are locking)



D. Laptop Cart # PC-S with stainless steel top

- Pneumatic height adjustment
- Height of work surface ranges from the floor: 27" to 37"
- 24"Wx24"D stainless steel top
- Handle
- Footprint: 23" diameter five-prong base
- Five 4" twin casters (the front two are locking)



E. Laptop Cart with a fixed height

- 20"W x 20"D phenolic work surface with two built-in handles
- Height of work surface from the floor: 42"
- Shelf for CPU/UPS or battery: 18"W x 18"D
- Four 4" twin casters (the front two are locking)

Tablet Cart LPC300

At AFC Industries we are committed to creating end-user solutions driven by new technologies. The latest advancements point to the handheld tablet as an increasing popular device. Far more flexible and bedside-friendly than even small laptops, these handheld devices promote safer, better, and faster care

by enabling doctors and other caregivers to educate and involve their patients in the process. Patients often don't grasp what doctors tell them, and showing them high-quality images and videos can help.

Enter the AFC Tablet Cart which was created specifically to hold a

tablet or iPad. This height adjustable unit delivers the same quality and performance that you have come to expect from AFC, and a multitude of features and mounting options that can truly deliver the ergonomic experience so necessary for today's clinician.

A. Tablet Cart # LPC300 with grommet-mount tablet holder and metal enclosure

- Pneumatic height adjustment
- Grommet-mount arm # AFC01 with tablet holder
- Metal enclosure with removable side covers
- 18"W x 23"D phenolic work surface with handle
- Height of work surface ranges from the floor: 28" to 48"
- Right and left sliding mouse tray
- Footprint: 23" diameter five-prong base
- Additional base weight for increased stability
- Five 4" twin casters



Grommet-mount arm # AFC01 with tablet holder

B. Tablet Cart # LPC300 with Z-series tablet holder and metal enclosure

- Pneumatic height adjustment
- Tablet holder on Z-arm # AFCZ566
- Metal enclosure
- 18"W x 25"D phenolic work surface with handle
- Height of work surface ranges from the floor: 28" to 42"
- Right and left sliding mouse tray
- Wire basket # WB-100
- Footprint: 23" diameter five-prong base
- Additional base weight for increased stability
- Five 4" twin casters



Tablet holder on Z-arm # AFCZ566

Telescopic Cart™

The **Telescopic Cart™** is designed to accommodate tight spaces. The work surface is electronically height-adjustable to enhance comfort and ease of use, whether the operator is seated or standing. Mobile with stable locking casters, the strong, durable **Telescopic**

Cart™ can be stationed wherever needed and makes adding an extra workstation easy and affordable. Available in different width and depth combinations, the cart can accommodate up to two flat panel monitors.

All sizes are customizable with grommet-mount or clamp-style monitor arms, multiple laminate finishes and colors, keyboard arms and trays, and larger casters for two additional inches of height.

Electronic Adjustment:

▪ SURFACE HEIGHT

Features and Benefits

- Cold-rolled 11-gauge steel frame with epoxy-powder-coated finish
- Particle-board-core top with your choice of high-pressure laminate finish
- Chemical-resistant phenolic top and bottom surfaces available
- Work surface is electronically height-adjustable with optional electronic tilt
- Multiple colors available (for standard colors, see page 103)
- Four four-inch casters (the front two are locking)
- Glides and additional accessories available (see page 92)

Specifications

- Width: 24", 30", 36"
- Depth: 24", 30", 36"
- Height of work surface from the floor: 30" to 46"

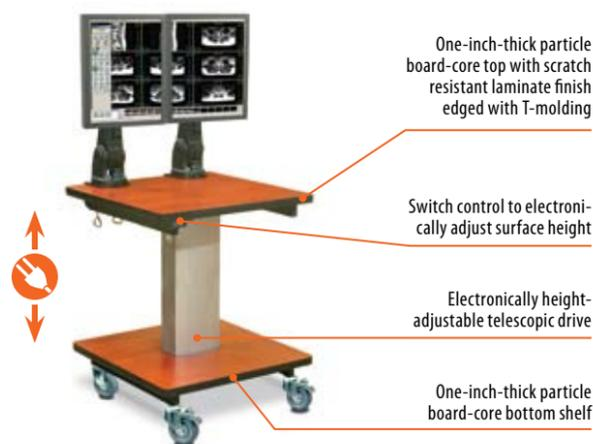

A. Telescopic Cart™ 24"W x 24"D with Standard work surface shape

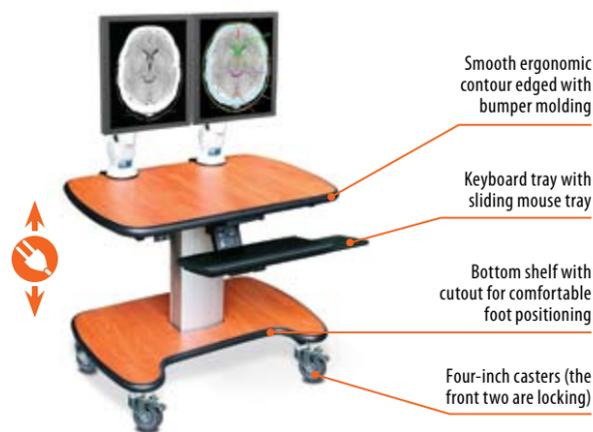

B. Telescopic Cart™ 24"W x 24"D with Deluxe work surface shape

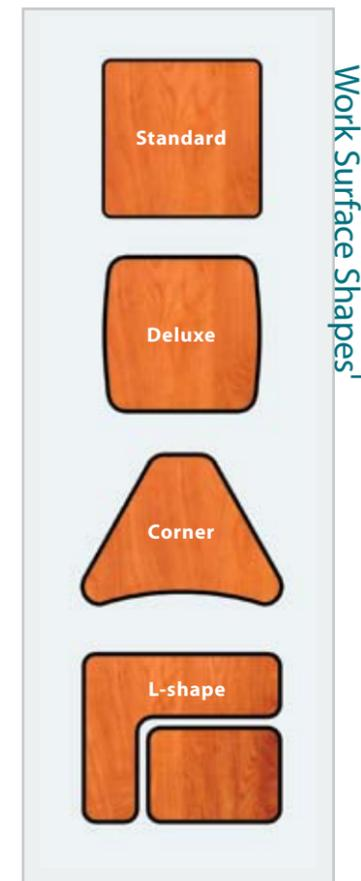

1 Availability of shape depends on size of the cart

Telescopic Cart™ Sizes		
24"W x 24"D	30"W x 24"D	36"W x 24"D
24"W x 30"D	30"W x 30"D	36"W x 30"D
24"W x 36"D	30"W x 36"D	36"W x 36"D
Accommodates one flat panel monitor	Accommodates up to two flat panel monitors	Accommodates up to two flat panel monitors



C. Telescopic Cart™ LTC4236-01 42"W x 36"D:

- L-shape work surface
- Grommet-mount Z-arm # AFCZ588-02
- Swinglift Keyboard Arm # KA7001
- CPU Holder # CPU 13-25
- LED Task Light # TAL400

12.2" vertical travel of the Swinglift Keyboard Arm allows use of keyboard and mouse while seated or standing up



Tilted position (electronic tilt from -5° to +10°)

D. Telescopic Cart™ 36"W x 30"D with electronically tilting work surface¹

1 Shown with custom base

E. Telescopic Cart™
30"W x 30"D:

- Standard work surface shape
- Chemical-resistant phenolic work surface and bottom shelf
- Grommet-mount twin Monitor Arm # AFCPOLE2MH-1



Grommet-mount
Twin Monitor Arm
AFCPOLE2MH-1

F. Telescopic Cart™
24"W x 24"D:

- Deluxe work surface shape
- Clamp-mount twin Monitor Arm # AFCPOLE2MH-1
- Retractable Keyboard Tray # KB01
- CPU Holder
- Wire Basket # WB-100
- Wire Manager # WMF100
- CPU Holder # CPU-99



Wire basket

G. Telescopic Cart™
24"W x 24"D:

- Deluxe work surface shape
- Clamp-mount Monitor Arm # AFCFLEXOARM
- Keyboard Arm # KA6000
- Keyboard Tray # TR2000 with sliding mouse tray
- Two foldable extensions



Foldable extension

H. Telescopic Cart™
30"W x 24"D:

- Corner work surface shape
- Keyboard Arm # KA6000
- Keyboard Tray # TR2000 with sliding mouse tray



Interactive Builder



Configure your own
Telescopic Cart™ at
www.afcindustries.com/telescopiccart

Plasma Cart™

As technology has become an integral part of the workflow, the need for easy, convenient data access has grown. The **Plasma Cart™** is a durable, sturdy, adjustable and mobile solution for data and video access. Applications include teaching and training, meetings and presentations, teleconferences, telemedicine, signage and more. These units are ideally suited for government, military and other mission critical, commerce, healthcare, education and more.

The **Plasma Cart™** allows you to strategically bring a large flat screen and related electronic equipment wherever they are needed. It accommodates large flat screens with allowing tilt from -5° to +15°. All components of the **Plasma Cart™** are height adjustable. Internal wire management is enclosed by easy-to-remove access panels.

The **Plasma Cart™** can be configured according to the user's specific needs and enhanced with multiple

options, such as double-monitor holder, retractable keyboard and laptop tray, additional shelves, CPU holder, camera holder for teleconferencing, telemedicine, and filming applications.

Our **Mini Plasma Cart™** series accommodate screens between 24"-38"* and have all standard features of **XLCD** series in a smaller footprint with the option for height adjustable components.

* Will work with smaller sizes and depending on the weight of the screen



Features and Benefits

- Fits multiple size flat screens
- Monitor mount tilts from -5° to +15°
- Mobile and stable
- All components are individually height adjustable
- Built-in cable management with removable access panel

Specifications

- Utility shelf: 18"W x 16"D
- Footprint: 30"W x 30"D
- Four-inch casters (the front two are locking)
- Overall height from the floor: 62"

Optional

- Multiple monitor holder
- Retractable keyboard/laptop tray
- Additional shelves
- CPU holder
- Camera holder
- Surge suppressor
- Glides and additional accessories (see page 92)

Available Colors

- Putty
- Black
- Gray
- White



The **Plasma Cart™** provides a mobile display wherever it is needed, perfect for both public spaces and meeting rooms.

A. Plasma Cart™
XLCD200-01

- Large monitor holder # AFC2346-01
- Camera holder
- Utility shelf
- Four 4" casters



Built-in cable management system provides a neat and safe solution for wires



Built-in cutouts for cable management



A surge suppressor can be mounted out of sight, inside the cable management channel



Wires are tucked away behind an easily removable access panel



Plasma Cart™ XLCD200-01 (front view)



Plasma Cart™ XLCD200-01 (back view)



- D. Plasma Cart™ XLCD300-01**
- Large monitor holder # AFC2346-01
 - Four monitor arms # AFC2530 on foldable wings
 - Camera holder
 - Utility shelf
 - Footprint: 48"W x 34"D



B. Mini Plasma Cart™ MLCD200-01

- Monitor Arm # AFCZ5-00
- Camera holder
- 19.5"W x 17"D shelf for keyboard with sliding mouse tray and mouse holder
- Wire Basket # WB-100
- 19.5"W x 17"D shelf for printer
- 14"W x 16"D metal shelf
- Enclosure for transformer



C. Mini Plasma Cart™ MLCD200-01

- Monitor Arm # AFCZ5-00
- Retractable Keyboard Arm & Tray # WM-TR-M with sliding mouse tray
- Utility shelf: 18"W x 18"D
- CPU Holder # CPU-13-25
- File/cassette holder
- Shelf for UPS: 14"W x 12"D
- Footprint: 24"W x 24"D



E. Mini Plasma Cart™ MLCD400-01

- Monitor Arm # AFCZ5-00
- Lockable enclosure with retractable Keyboard Tray and sliding mouse tray
- Wire Basket # WB-100
- CPU Holder # CPU-101
- Straight base: 30"W x 26"D



F. Plasma Cart™ XLCD500

- Two Monitor Arms # AFCZ5-00
- Retractable Keyboard Arm & Tray # WM-TR-M with sliding mouse tray
- Handle
- CPU Holder # CPU-13-25
- CPU Holder # CPU-101
- Footprint: 30"W x 30"D



Front view



Back view

G. Plasma Cart™ XLCD500

- Two Monitor Arms # AFCZ5-00
- Z-series Keyboard Arm & Tray with sliding mouse tray # WM-ZKB-1
- Handle
- Two utility shelves
- Printer shelf
- Footprint: 30"W x 30"D

Pole Cart™

The compact size and adaptable nature of the Pole Cart™ make it highly useful in a variety of applications and perfect for tight, high-traffic areas. It easily moves a computer system from one location to another and supports up to two flat-panel monitors, a keyboard, and a CPU.

The Pole Cart™ can be adjusted from a seated to a standing position.

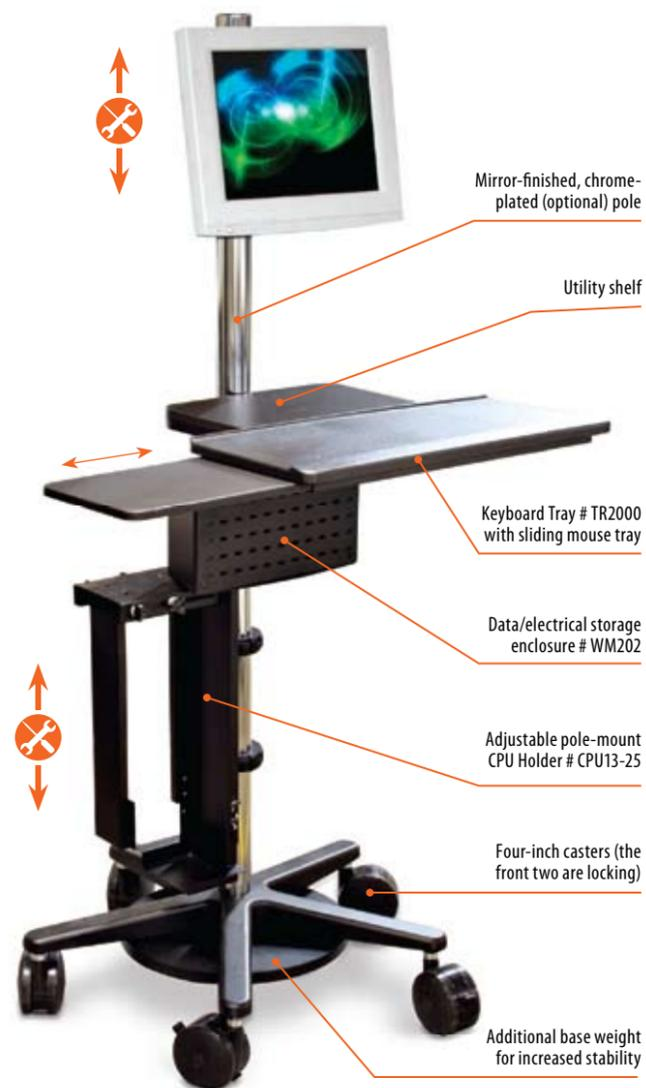

Pole Cart™ MPC200

View A



Pole-mount Monitor Arm # AFCZ5-00 with tilt & pan movements

View B



Steel pole with cutouts (two front and one rear) for wire management

Features and Benefits

- Steel pole with built-in wire management (View B)
- Available with laminate, square metal base, or five-prong metal base
- All individual components are height-adjustable and can be rotated 360 degrees around the pole
- Pole finish:
Mirror-finished chrome-plated or
Multiple colors available (for standard colors, see page 103)
- Additional accessories available (see page 92)

Specifications

- Pole: 2" outside diameter
- Footprint:
Square base — 21"W x 21"D
Five-prong base — 26" diameter
- Four-inch casters (two of them locking)
- Overall height from the floor: 60", 72"

Available Colors

- Black
- Gray
- Putty
- White

A. Pole Cart™ MPC200

- Black epoxy-powder-coated finish pole with built-in cutout for wire management
- Pole-mount Monitor Arm # AFCZ5-00
- Utility shelf
- Keyboard Tray # TR2000 with sliding mouse tray
- Two pole-mount CPU Enclosures # CPU-09
- Additional base weight for increased stability
- Five 4" casters



B. Pole Cart™ MPC200

- Black epoxy-powder-coated finish pole with built-in cutout for wire management
- Pole-mount Monitor Arm # AFCZ5-00
- Handle
- Utility shelf
- Keyboard Tray # TR2000 with sliding mouse tray
- Data/electrical storage enclosure # WM202
- Adjustable pole-mount CPU Holder # CPU13-25
- Additional base weight for increased stability
- Five 4" casters



C. Pole Cart™ MPC200

- Black epoxy-powder-coated finish pole with built-in cutout for wire management
- Pole-mount Twin Monitor Arm # AFCPOLE2MH-1
- Handle
- Utility shelf
- Keyboard Tray # TR2000 with sliding mouse tray
- Data/electrical storage enclosure # WM202
- Retractable Power Cord # RPC-101
- Two pole-mount CPU Holders # CPU-101
- Additional base weight for increased stability
- Five 4" casters



D. Pole Cart™ MPC200 with laminate base

- Black epoxy-powder-coated finish pole
- Pole-mount Monitor Arm # AFCZ5-00
- Laminate utility shelf
- Metal Keyboard Tray with sliding mouse tray
- Adjustable pole-mount CPU Holder # CPU13-25
- Laminate base edged with bumper molding
- Four 4" casters

E. Pole Cart™ MPC200 with square metal base

- Black epoxy-powder-coated finish pole
- Pole-mount Z-arm # AFCZ588-01
- Metal Keyboard Tray with sliding mouse tray
- Adjustable pole-mount CPU Holder # CPU13-25
- Square metal base
- Four 4" casters



Z-series Arm # AFCZ588-02

F. Pole Cart™ MPC200 with square metal base

- Black epoxy-powder-coated finish pole
- Pole-mount Z-arm # AFCZ588-02
- Keyboard Tray # TR2000 with sliding mouse tray
- Adjustable pole-mount CPU Holder # CPU13-25
- Square metal base
- Four 4" casters

As telemedicine rapidly develops where medical information is transmitted for the purpose of consulting, and sometimes remote medical procedures or examinations, AFC Industries offers the **Pole Cart™** equipped with a camera holder.

Useful for bedside and patient interaction from your home or office, or when health professionals are discussing a case over the telephone, or as complex as using satellite technology and videoconferencing equipment to conduct a real-time consultation between medical specialists in two different countries.

G. Pole Cart™ MPC200

- Gray epoxy-powder-coated finish pole with built-in cutout for wire management
- Height-adjustable camera holder
- Handle
- 18"Wx16"D shelf with drawer
- Speaker shelf
- Wire basket # WB-100
- Pole-mount CPU Holder # CPU-101
- Additional base weight for increased stability
- Five 4" casters



H. Pole Cart™ MPC200

- Mirror-finished, chrome-plated pole with built-in cutout for wire management
- Pole-mount camera shelf
- Pole-mount Monitor Arm # AFZ5-00 with tilt & pan movements
- Pole-mount Scanner Holder # S01
- Handle
- Pole-mount laptop platform
- Pole-mount CPU cradle
- Wire Manager
- Base-mount CPU cradle
- Additional base weight for increased stability
- Five 4" casters

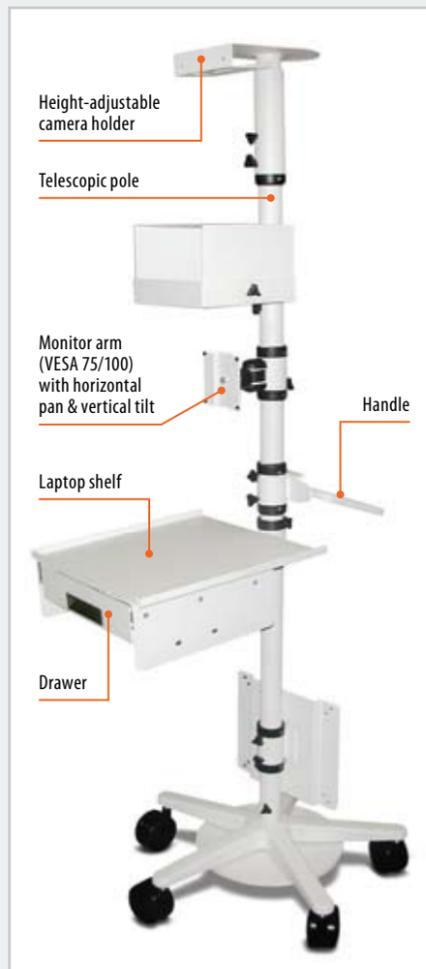

I. Pole Cart™ MPC600_CSX_07

- Gray epoxy-powder-coated finish telescopic pole
- Height-adjustable camera holder
- Transmitter holder
- Pole-mount Monitor Arm # AFC17H
- Handle
- Laptop shelf with drawer
- Mounting bracket for transformer
- Additional base weight for increased stability
- Five 4" casters



Pole Cart™ is perfect for tight, high-traffic areas

We also offer a **Pole Station™** with a round metal base that is fixed to the floor¹

J. Pole Station™ # FPP

- Gray epoxy-powder-coated finish pole with built-in cutout for wire management
- Z-series Monitor Arm # AFC588-01
- Z-series Keyboard Arm with sliding mouse tray # ZKB-P
- Pole-mount CPU Holder # CPU-101
- Floor-mounted 16" diameter metal base



¹ Has to be bolted

K. Pole Station™ # FPP

- Black epoxy-powder-coated finish pole with built-in cutout for wire management
- Pole-mount Monitor Arm # AFCZ5-00
- Two utility shelves
- Pole-mount Scanner Holder # S01
- Metal Keyboard Tray with sliding mouse tray
- Two Wire Baskets # WB-100
- Pole-mount CPU Holder # CPU-101
- Printer shelf
- Floor-mounted 16" diameter metal base





Carts & Racking Systems enhance and organize your workspace

AFC understands the need to implement ergonomics in all work environments, which is why our carts and racking systems are designed and manufactured to fit the end users. On-staff engineers can customize carts and racking systems to meet your specific requirements. "Studies have shown that ergonomic improvements result in productivity increases, dramatic increases in worker satisfaction, and a significant decrease in workplace injuries." (www.HealthyComputing.com)

SmartRack™

The SmartRack™ is a modular space-saving solution that accommodates a variety of technical equipment. Highly versatile, it comes in multiple configurations for mounting LCDs, CRTs, CPUs, and all standard 19-inch rack-mount equipment.

Features and Benefits

- Cold-rolled 11-gauge steel frame with epoxy-powder-coated finish
- Particle-board-core top with your choice of high-pressure laminate finish
- Customized Ergonomic and Standard work surfaces available edged with T-molding/bumper molding
- Work surface and shelves are height-adjustable in one-inch increments
- Customized metal or wood shelves, fully adjustable and tiltable
- Multiple colors available (for standard colors, see page 103)
- Built-in wire-management conduits
- Glides and additional accessories available (see page 92)

Specifications

- Width of frame: 24", 30", 36"
- Depth: 24", 30", 36"
- Height of frame: 36", 48", 60", 73", 83"
- Two-inch casters (the front two are locking)

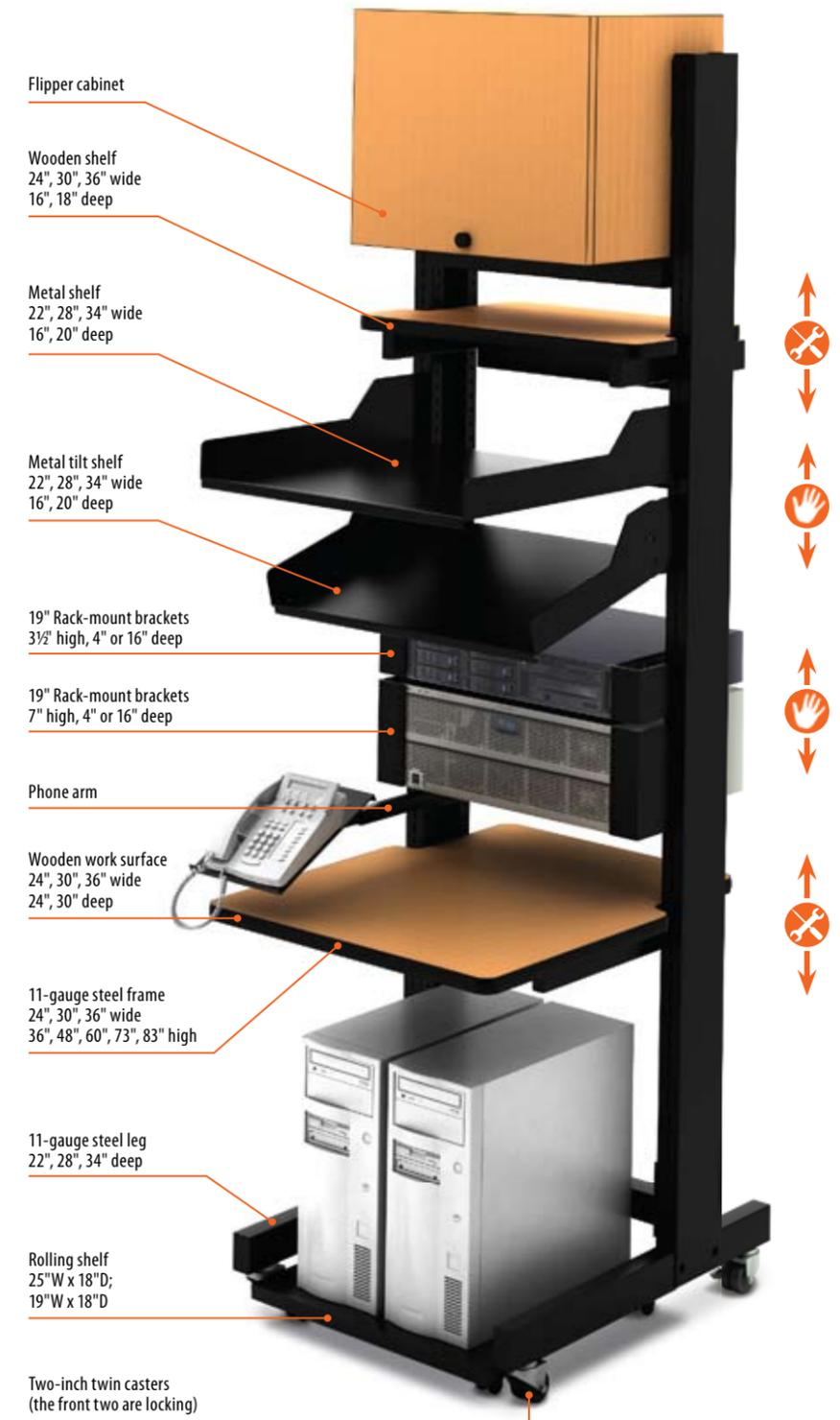

SmartRack™ Basic Components



A. SmartRack™ 60"W x 30"D x 76"H:

- Two 30" wide frames
- Two metal top shelves
- Metal tilt shelf
- Rack-mount brackets 7"H x 4"D
- Adjustable Phone Arm # TA001
- Standard work surface shape
- Z-series monitor Arms # AFCZ500-01 and # AFCZ500-02
- Two Keyboard Arms # KA6000
- Two Keyboard Trays # TR2000 with sliding mouse trays
- Two rolling shelves



B. SmartRack™ 30"W x 30"D x 76"H:

- 30" wide frame
- Top metal tilt shelf
- Middle metal shelf
- Rack-mount brackets 7"H x 16"D
- Rack-mount brackets 7"H x 4"D
- Standard work surface shape
- Keyboard Arm # KA6000
- Keyboard Tray # TR2000 with sliding mouse tray
- Flushed bottom shelf



C. SmartRack™ 30"W x 36"D x 76"H:

- 30" wide frame
- Metal top shelf
- Rack-mount brackets 7"H x 4"D
- Z-series Monitor Arm # AFCZ500-01
- Adjustable Phone Arm # TA001
- Standard work surface shape
- Keyboard Arm # KA6000
- Keyboard Tray # TR2000 with sliding mouse tray
- Rolling shelf



E. SmartRack™ 30"W x 30"D x 86"H:

- 30" wide frame
- Flipper cabinet # FC
- Six plastic bins
- Standard work surface shape

F. SmartRack™ 30"W x 30"D x 86"H:

- 30" wide frame
- Flipper cabinet # FC
- Wooden middle shelf
- Standard work surface shape
- Z-series monitor Arm # AFCZ500-01
- Keyboard Arm # KA6000
- Keyboard Tray # TR2000 with sliding mouse tray

G. SmartRack™ 30"W x 30"D x 86"H:

- 30" wide frame
- Flipper cabinet # FC
- Metal shelf
- Standard work surface shape
- Z-series Arm for two LCD monitors # AFCZ500-02
- Keyboard Arm # KA6000
- Keyboard Tray # TR2000 with sliding mouse tray
- Adjustable CPU Holder # CPU13-25



D. SmartRack™ 36"W x 30"D x 86"H:

- 36" wide frame
- Flipper cabinet # FC
- Standard work surface shape
- Modesty back panel # MBP
- Wall Mount with pneumatic adjustment of monitor, keyboard, and CPU # WM-RKMC-P

The racking systems accommodate a variety of technical equipment

Interactive Builder

Configure your own SmartRack™ at www.afcindustries.com/smartrack

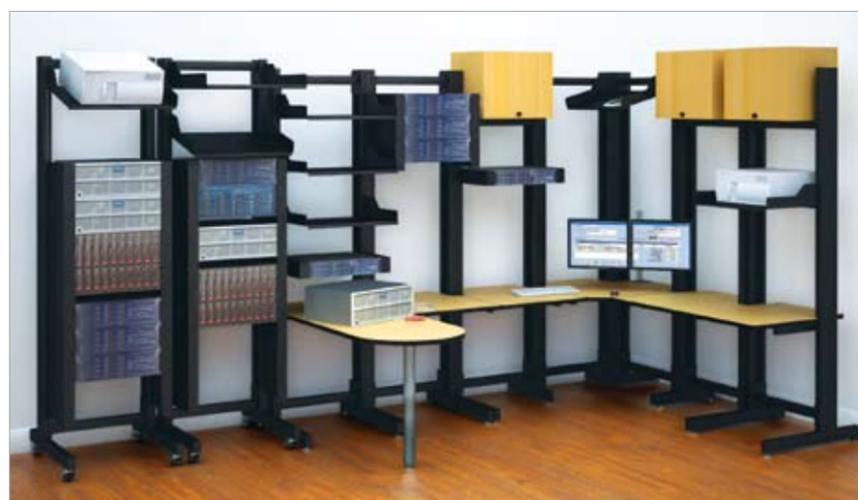

IntelliCart™

Featuring cutting-edge design and flexibility, the IntelliCart™ gives you the versatility and mobility you have been looking for. Its soothing, fluid lines bring a relaxing touch to busy work environments. With an elegant yet simple design, it is a strong and comfortable workstation that will last a lifetime.



Features and Benefits

- Cold-rolled 11-gauge steel frame with epoxy-powder-coated finish
- Particle-board-core top with your choice of high-pressure laminate finish
- 16" deep top shelf and 18" deep bottom shelf
- Work surface and shelves edged with bumper molding
- Work surface is height-adjustable in one-inch increments
- Customized ergonomic work surfaces available
- Multiple colors available (for standard colors, see page 103)
- Two-inch or four-inch casters (two of them locking)
- Glides and additional accessories available (see page 92)

Specifications

- Width: 36", 48", 60", 72"
- Depth: 30", 36"
- Height from the floor:
Work surface: 30"
Top shelf: 36"

Optional
Swinglift
Keyboard
Arm

Work Surface Shape

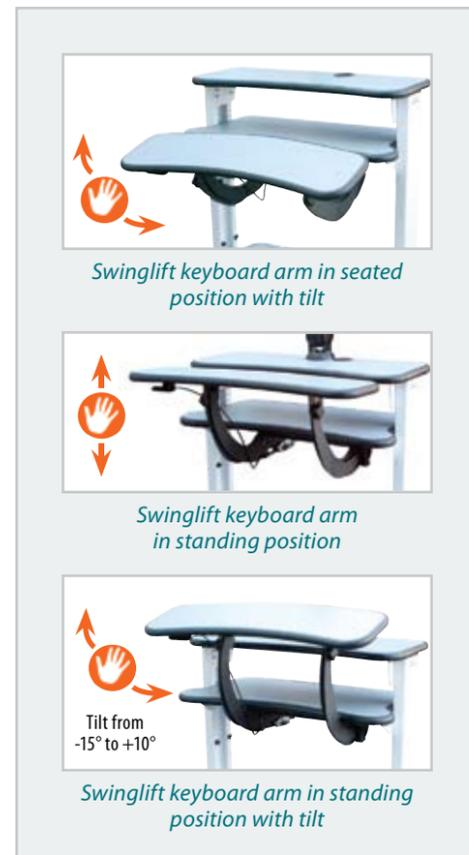

A. IntelliCart™ 36"W x 30"D x 36"H:

- Top shelf
- Two clamp-mount Monitor Arms # AFC02
- Keyboard Arm # KA6000
- Keyboard Tray # TR2000 with sliding mouse tray
- Flushed bottom shelf
- 4" casters



D. IntelliCart™ 48"W x 30"D x 36"H:

- Top shelf
- Two clamp-mount Monitor Arms # AFC02
- Keyboard Arm # KA6000
- Keyboard Tray # TR2000 with sliding mouse tray
- Flushed bottom shelf
- 2" twin casters

B. IntelliCart™ 36"W x 30"D x 36"H:

- Top shelf
- Clamp-mount Monitor Arm # AFC02
- Swinglift Keyboard Arm # KA7001
- Flushed bottom shelf
- 2" twin casters



E. IntelliCart™ 72"W x 36"D x 36"H:

- Top shelf
- Three clamp-mount Monitor Arms # AFC02
- Keyboard Arm # KA6000
- Keyboard Tray # TR2000 with sliding mouse tray
- Flushed bottom shelf
- 2" twin casters

C. IntelliCart™ 48"W x 30"D x 72"H:

- Flipper cabinet # FC
- Middle shelf
- Swinglift Keyboard Arm # KA7001
- Handle
- Flushed bottom shelf
- 2" twin casters



F. IntelliCart™ 48"W x 30"D x 72"H:

- Flipper cabinet # FC
- Middle shelf
- Swinglift Keyboard Arm # KA7001
- CPU Holder # CPU-05
- Flushed bottom shelf
- 2" twin casters

SmartCart™

The versatility offered by AFC's **SmartCart™** makes it a wonderful addition to any work environment. With virtually limitless configurations and customization, this cart fits your needs perfectly. All **SmartCarts™** are exclusively built from reinforced steel with pressurized scratch-resistant laminate surfaces, making them extremely strong and durable.

Choose from any combination of features and let us create the **SmartCart™** that is right for you. No matter what your workplace requirements, you will find that our ergonomically designed **SmartCarts™** enhance productivity and give you a lifetime of dependable and enjoyable service.

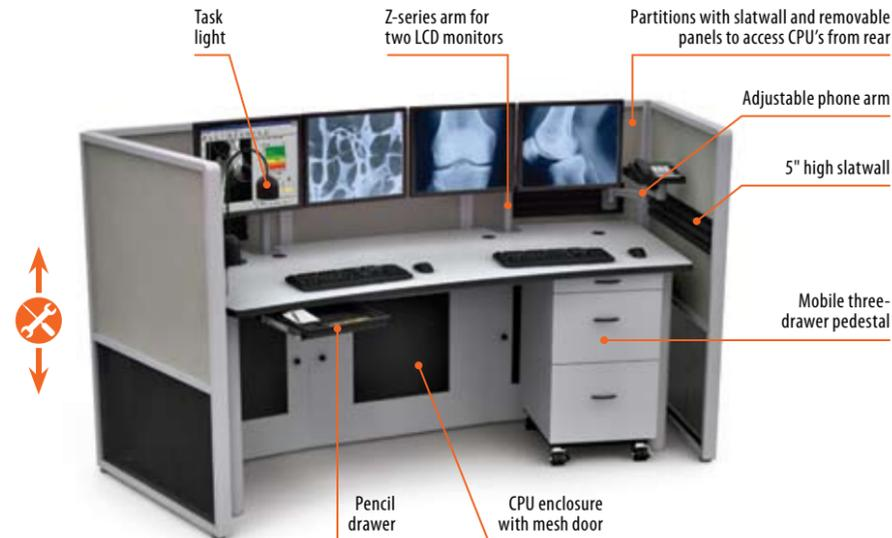

A. SmartCart™ 84"W x 32"D with partitions and slatwalls

Features and Benefits

- Cold-rolled 11-gauge steel frame with epoxy-powder-coated finish
- Particle-board-core top with your choice of high-pressure laminate finish
- Customized ergonomic and standard work surfaces available edged with T-molding/bumper molding
- Work surface and shelves are height-adjustable in one-inch increments
- 16" deep split bottom shelf on either one or both sides provides leg space; full-length bottom shelf accommodates CPU or other computer-related equipment
- Multiple colors available (for standard colors, see page 103)
- Two-inch or four-inch casters (two of them locking)
- Glides and additional accessories available (see page 92)

Interactive Builder



Configure your own **SmartCart™** at www.afcindustries.com/smartcart

Specifications

- Width: 18", 24", 30", 36", 48", 60", 72", 84", 96"
- Depth: 18", 24", 30", 36"
- Height of work surface from the floor:
seated position: 30"–36"
standing position: 42"



B. SmartCart™ 24"W x 18"D x 44"H

Work Surface Shapes

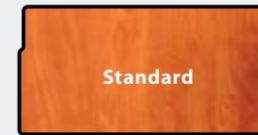

for all widths



for tables 48" wide and up



for all widths



for tables 60" wide and up



for tables 48" wide and up



for tables 48" wide and up



for tables 60" wide and up



for tables 48" wide and up



C. SmartCart™ 18"W x 20"D x 42"H:

- Standard work surface shape
- Clamp-mount Monitor Arm # AFC02
- Keyboard Arm # KA6000
- Keyboard Tray # TR2000 with sliding mouse tray
- Storage cabinet
- 4" casters



D. SmartCart™ 24"W x 24"D x 30"H:

- Standard work surface shape
- Retractable Keyboard Tray # KB01
- Side mount CPU Holder
- Glides



E. SmartCart™ 30"W x 24"D x 30"H:

- Standard work surface shape
- Clamp-mount Monitor Arm # AFCPOLE
- Retractable Keyboard Tray # KB01
- Split bottom shelf
- Glides



F. SmartCart™ 60"W x 36"D:

- Z-series Monitor Arms # AFCZ588-02 and # AFCZ588-01
- Swinglift keyboard arm
- Task light # TAL200A with dimer
- Bottom shelf
- Two CPU cradles # CPU-07
- Two wire managers # WMF100



Available in a variety of configurations, this cart can do any job. Its mobility enables it to go right to the action or, when necessary, stay out of the way.

G. SmartCart™ 30"W x 30"D x 54"H:

- Top shelf
- Standard work surface shape
- Clamp-mount Z-arm # AFCZ588-02
- 2" twin casters

1 shown with two-door cabinet



H. SmartCart™ 48"W x 30"D x 54"H:

- Top shelf
- Standard work surface shape
- Clamp-mount Z-arm # AFCZ588-02
- CPU Holder # CPU 13-25
- 2" twin casters

2 shown with one and two-door cabinets



I. SmartCart™ 60"W x 30"D x 54"H:

- Top shelf
- Standard work surface shape
- Clamp-mount Z-arm # AFCZ588-02
- Pedestal with 2 drawers # P2FF15MF
- CPU Enclosure
- 2" twin casters

3 shown with one-door cabinet



J. Custom SmartCart™ 48"W x 36"D x 42"H:

- Standard work surface shape
- Z-arm # AFCZ588-02
- Two Phone Arms # TA002
- Pencil Drawer # PD002
- Two adjustable CPU Holders # CPU13-25
- Slatwall
- Glides



K. SmartCart™ 84"W x 34"D x 30"H:

- Custom work surface shape
- Clamp-mount Z-arm # AFCZ588-02
- Keyboard Arm # KA6000 with wooden keyboard tray
- Two split bottom shelves
- Glides



L. SmartCart™ 84"W x 36"D x 30"H:

- Ergonomic Hexagon with Cutout work surface shape
- Swinglift Keyboard Arm # KA7001
- Clamp-mount Z-arm # AFCZ568-02
- Bottom shelf
- Glides



M. SmartCart™ 60"W x 24"D x 76"H:

- Flipper cabinet with two doors # FC
- Standard work surface shape
- Grommet-mount Monitor Arm # AFC01
- Task Light # TAL200A
- Phone Arm # TA002
- Keyboard Arm # KA6000
- Keyboard Tray # TR2000 with sliding mouse tray
- Film Box # FB-100-1 and storage cabinet on bottom shelf
- Mobile CPU Cradle # CPU-02
- 2" twin casters



N. SmartCart™ 36"W x 30"D x 30"H:

- Standard work surface shape
- Telescopic Monitor Arm
- Flushed bottom shelf
- 2" twin casters

Back view



The Telescopic Arm allows the user:

- to stow the monitor below the work surface when not in use
- to rotate screen 180° for training purposes

A variety of "L" and corner configurations are available (see next page). Select the shape and size best suited to your application, or call us for a customized solution.

A variety of "L" and corner configurations are available. Select the shape and size best suited to your application, or call us for a customized solution.

"L" and Corner Work Surface Configurations

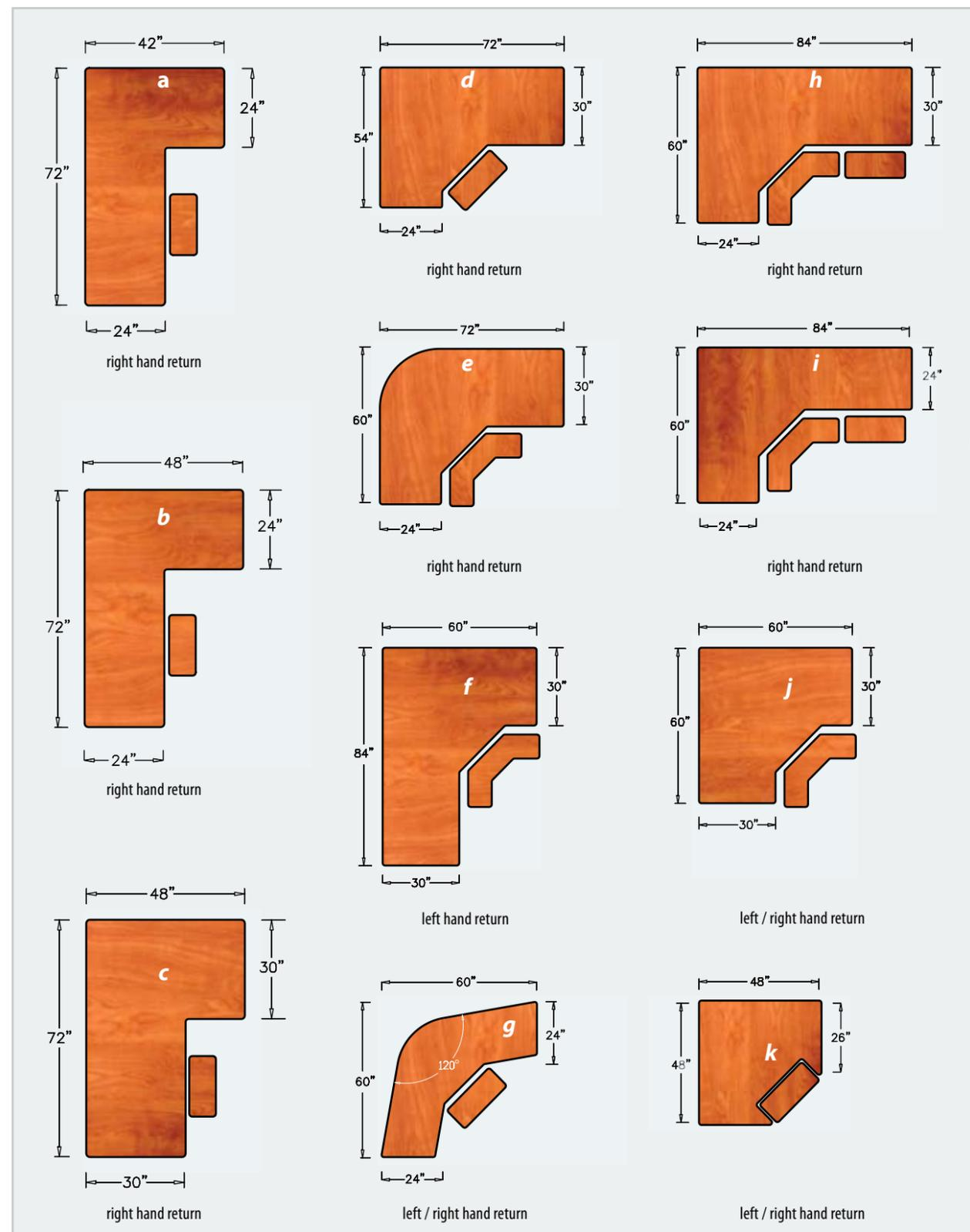

O. SmartCart™ 32"W x 32"W x 38"H:

- Top shelf
- Corner work surface shape
- Keyboard Arm # KA6000
- Keyboard Tray # TR2000 with sliding mouse tray
- Flushed bottom shelf
- 2" twin casters



Q. SmartCart™ 48"W x 48"W x 42"H:

- Custom work surface shape
- Retractable Keyboard Tray # KB01
- 2" twin casters



R. SmartCart™ 60"W x 39"W x 30"H:

- Corner work surface shape
- Keyboard Arm # KA6000
- Keyboard Tray # TR2000 with sliding mouse tray
- Split bottom shelf
- 2" twin casters



D. SmartCart™ 96"W x 72"W x 76"H:

- Flipper cabinet with two doors
- Middle shelf
- Z-series monitor arm # AFCZ500-2
- Under-desk-mount pedestal with drawer and file
- Flushed bottom shelf
- 2" twin casters



S. SmartCart™ 93"W x 46"W x 30"H:

- Half-moon work surface shape edged with bumper molding
- Three clamp-mount Z-arms # AFCZ588-01
- Keyboard Arm # KA6000
- Keyboard Tray # TR2000 with sliding mouse tray
- Flushed bottom shelf
- 4" casters

T. SmartCart™ 96"W x 72"W x 76"H:

- Flipper cabinet # FC
- Middle shelf
- Custom work surface shape edged with bumper molding
- Back modesty panel
- 2" twin casters

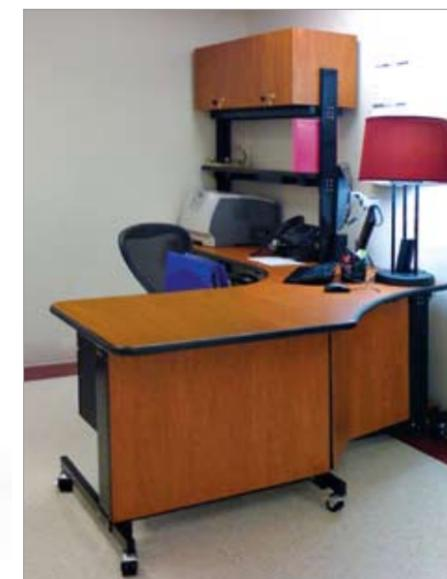

OmniBus™

The OmniBus™ provides maximum equipment support with a flexible profile that allows you to combine carts of different widths and heights. Call us with your specific needs and we will customize an OmniBus™ suited to your requirements.

Features and Benefits

- Cold rolled 11-gauge steel frame with epoxy-powder coated finish
- Particle-board-core top with your choice of high pressure laminate finish
- Customized ergonomic and standard work surfaces available edged with T-molding/bumper molding
- Work surface and shelves are height adjustable in one-inch increments
- Multiple colors available (for standard colors, see page 103)
- 2" or 4" casters (two of them locking)
- Glides and additional accessories available (see page 92)

Specifications

- Width: each side can be either 18", 24", 30", or 36" wide
- Any combination of these 4 widths is possible, so the total widths for the OmniBus™ are: 36", 42", 48", 54", 60", 72"
- Depth: 18", 24", 30", 36"
- Height: up to 72" from the floor



A. OmniBus™ 72"W x 36"D x 72"H with two-door flipper cabinet



- B. OmniBus™ 60"W x 30"D x 48"H:**
- Top shelf
 - Standard work surface shape
 - Unflushed bottom shelf
 - Flushed bottom shelf
 - Side and back modesty panels
 - 2" twin casters

- C. OmniBus™ 36"W x 30"D x 42"H:**
- Standard work surface shape
 - Clamp-mount Monitor Arm # AFC02
 - Keyboard Arm # KA6000 with custom Keyboard Tray
 - Middle shelf
 - Side shelf
 - Unflushed bottom shelf
 - Flushed bottom shelf
 - 4" Casters



- D. OmniBus™ 48"W x 30"D x 54"H:**
- Top shelf
 - Standard work surface shape
 - Side shelf
 - Unflushed bottom shelf
 - Flushed bottom shelf
 - 4" casters



- E. OmniBus™ 48"W x 36"D x 48"H:**
- Top shelf
 - Standard work surface shape
 - Two clamp-mount Monitor Arms # AFC02
 - Keyboard Arm # KA6000
 - Keyboard Tray # TR2000 with sliding mouse tray
 - Side shelf
 - Unflushed bottom shelf
 - Flushed bottom shelf
 - 2" twin casters



- F. OmniBus™ 48"W x 36"D x 48"H:**
- Top shelf
 - Standard work surface shape
 - Clamp-mount Z-arm # AFCZ588-02
 - Side shelf
 - Common flushed bottom shelf
 - 4" casters



- G. Custom OmniBus™ 48"W x 14"D x 48"H:**
- Standard work surface shape
 - Keyboard Arm # KA6000
 - Keyboard Tray # TR2000 with sliding mouse tray
 - Two side shelves
 - Common flushed bottom shelf
 - Glides



Keyboard arm # KA6000 allows the tray to tilt and pivot in any direction

Medical Equipment Cart

AFC Industries is a leading supplier of mobile equipment carts in the medical technology field. Engineered to function in small spaces and move easily, the medical equipment cart has been designed for, and has been tested in a variety of practical applications.

The cart is constructed using heavy duty cold-rolled steel with a powder-coated finish. An anti-microbial finish, a very important feature in the healthcare arena, is also available. Twin swivel casters provide for maximum ease of mobility and maneuverability.

The **medical equipment cart** follows a modular structure which allows for many different configurations and can be upgraded as required by the user based on their application. There is an extensive range of accessories, such as drawers, monitor arms, and CPU holders, that can be added on to the unit. OEM services available.

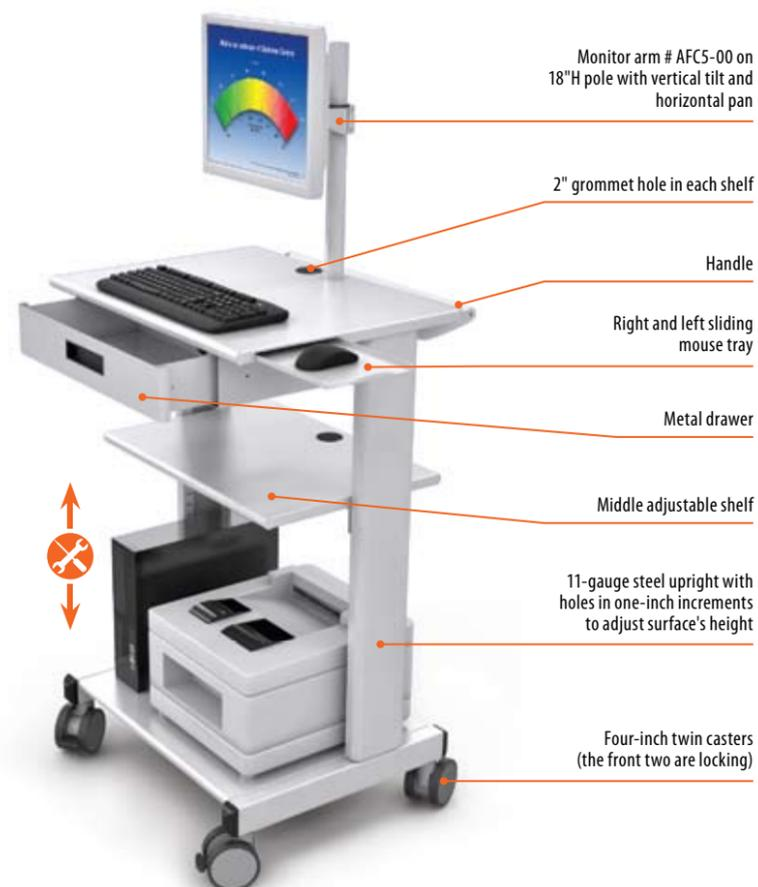

A. Medical Equipment Cart
26"W x 22"D x 42"H

Features and Benefits

- Cold rolled 11-gauge steel frame with epoxy-powder coated finish
- All-metal body enables disinfection and clean-room use
- Work surface and shelves are height-adjustable in one-inch increments
- VESA-compliant monitor holder
- Slide-out mouse tray
- Standard color: Textured Gray
- Multiple colors available (for standard colors, see page 103)
- Custom sizes available
- 4" twin casters (two of them locking)
- Additional accessories available (see page 92)

Specifications

- Width: 24", 30"
- Depth: 18", 24"
- Height of work surface from the floor:
seated position: 30"– 36"
standing position: 42"

Optional

- Back panel
- Monitor arms for two flat panel monitors

B. Medical Equipment Cart

26"W x 22"D x 42"H:

- Standard work surface shape
- Grommet-mount Monitor Arm # AFC7808
- Handle
- Retractable Mouse Tray
- Metal drawer
- Middle shelf
- Bottom shelf
- Back modesty panel
- 4" twin casters



Grommet-mount Monitor Arm
AFC7808

C. Medical Equipment Cart

26"W x 22"D x 42"H:

- Standard work surface shape
- Grommet-mount Z-arm for two monitors # AFCZ500-02
- Handle
- Metal drawer
- Retractable Mouse Tray
- Middle shelf
- Bottom shelf
- 4" twin casters



Optional Monitor Arm



Grommet-mount Monitor Arm
AFC7808_12_DM-01

- Light-weight aluminum construction for easy operation
- Entire mount is powdered coated in anti-microbial paint for thorough disinfection for safe use throughout medical facilities
- 41" of horizontal extension
- 12" range of height adjustment for accommodation of most users while standing or seated
- Full range of swivel motion at each joint.
- Integrated cable management keeps wires organized



When not in use, the arm folds up tight tucked away and unobtrusive

D. Medical Equipment Cart

26"W x 24"D x 42"H:

- Standard work surface shape
- Grommet-mount Z-arm for two monitors # AFCZ500-02
- Handle
- Retractable Mouse Tray
- Two metal drawers
- Two middle shelves
- 4" twin casters





Mounting solutions make the most of limited-space and decentralize data access

High traffic areas. Tight places. Operating rooms and emergency rooms. Inside and outside patient rooms. These are just some of the areas that are perfectly suited for AFC's variety of mounting solutions. Height-adjustable versions for seated or standing positions. Adaptable to any user. Making empty wall space productive.

Available in rich wood laminates, creating a warm and welcoming environment, as well as technical models traditionally associated with healthcare institutions. Decentralizing the availability of data for a greater return on investment in plant and human capital.

i-Center™

The innovative, space-saving **i-Center™** is an attractive wall-mounted workstation that enables computer access wherever needed, without utilizing floor space. The i-Center™ includes a fold-down keyboard tray with a damper for smooth operation and a VESA-compliant monitor holder. It accommodates any standard computer and turns empty wall space into a handy work area.

The **i-Center™** features all metal or laminated front and side walls that can be specified to match room décor, and mounts easily with grommet holes to

allow cabling. It has a removable front panel with security screws to prevent theft. Our new **i-Center # IR200-007** with self-closing keyboard tray, automatically closes securely protecting equipment, maintaining privacy, yet easily accessible, while optimizing floor space. Electronic keyless locks are also available, along with other accessories, such as cable management, power strips, and fans.

The **i-Center™** was designed to make the most of limited space in today's busy environments.

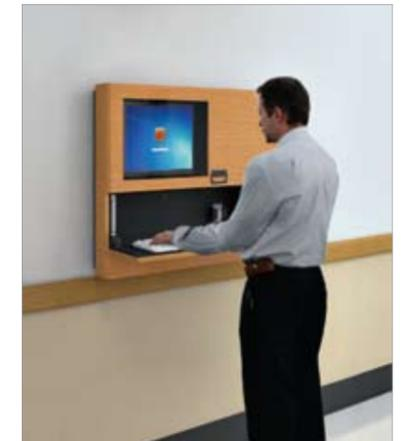

Features and Benefits

- Removable front panel with optional security screws and lock for keyboard shelf to prevent theft
- Fold-down keyboard tray with damper for smooth operation
- VESA-compliant monitor holder
- Grommet holes for cabling
- All metal or laminated front and side walls can coordinate with room décor
- Multiple colors available (for standard colors, see page 103)
- Custom sizes available

Specifications

- Width: 21 1/8" - 40"
- Height: 19 1/2" - 50"
- Depth: 3" - 9"

Optional

- Self closing keyboard tray
- Optional accessories include: CPU enclosure, mouse holder, scanner holder, cable management, power strips, and fan

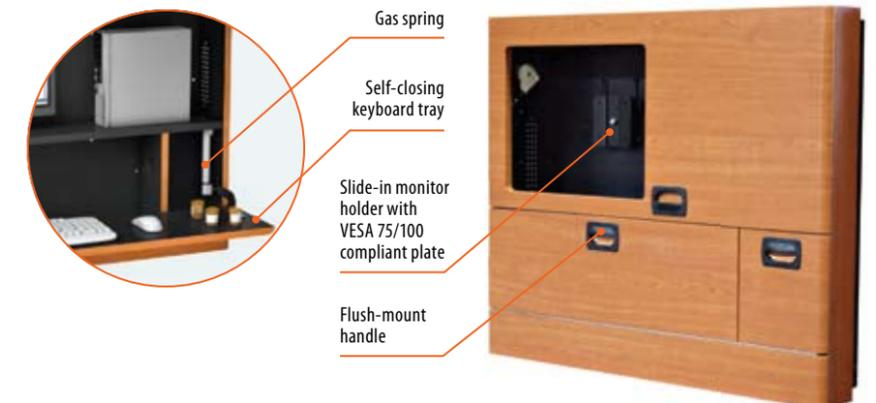

A. i-Center™ # IR200-007 (36"W x 6"D x 29 1/2"H) with self-closing keyboard tray, compartment for CPU and storage



B. i-Center™ # IR600 (25"W x 4"D x 19 1/2"H) for laptop with keyless lock

C. i-Center™ # IR100
(27"W x 6"D x 25 1/2"H)
with holder for thin client PC and sliding mouse tray

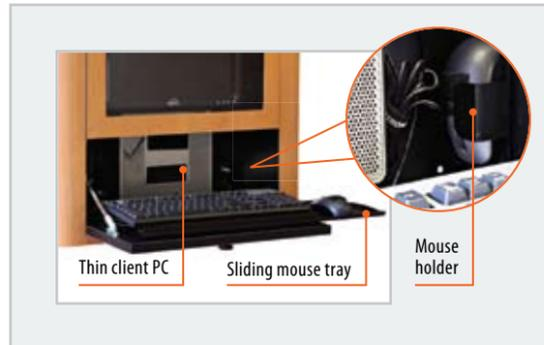
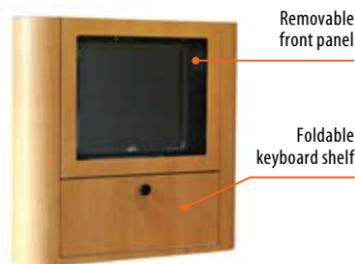

D. i-Center™ # IR300-009
(27"W x 6"D x 35"H)
with lockable front panel, wall-mount CPU enclosure for small-form-factor PC, and scanner holder

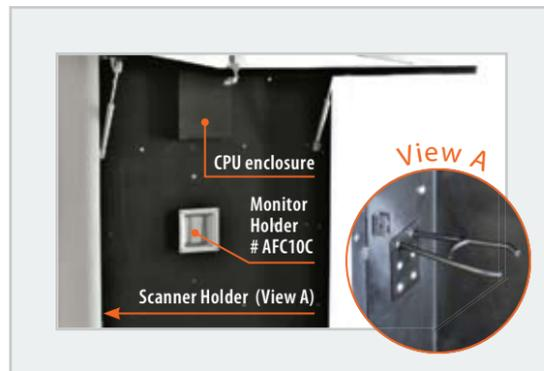
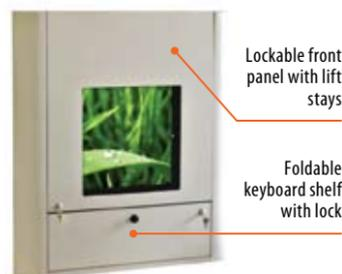

E. i-Center™ # IR300-001
(25 1/2"W x 6"D x 46 1/2"H)
with top flip-open-door CPU compartment and sliding mouse tray



F. i-Center™ # IR400-002
(34"W x 9"D x 50"H)
with top flip-open-door CPU compartment and Z-arm Combo



More Options for CPU



Our selection of all metal i-Centers™ offers a slim design to meet JCAHO standards, and comes complete with a myriad of features that enhance daily clinical workflow. Included are built in cut outs for power and data drops, a bottom compartment for thin power strip and cable management, a fixed VESA 75/100 mm monitor plate, gas springs for easy open/close at any height level, advanced security to protect patient data and provide protection from vandalism, theft, and incidental damage.

These metal units are perfectly suited for the medical industry as they are easy to clean/disinfect and also are available with antimicrobial coatings.

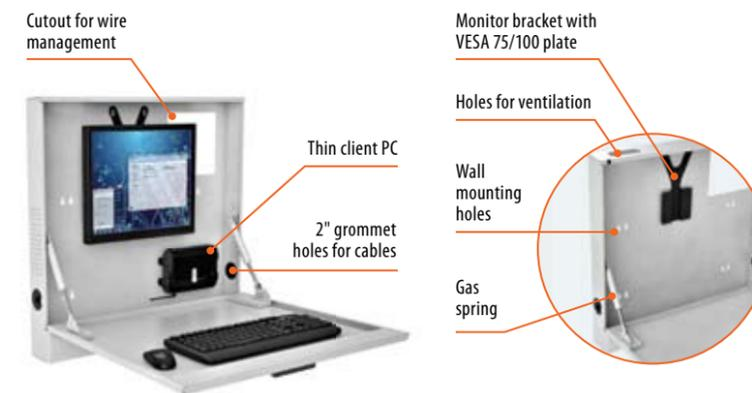

G. Metallic i-Center™ # IR850-002
(26"W x 4"D x 26"H)

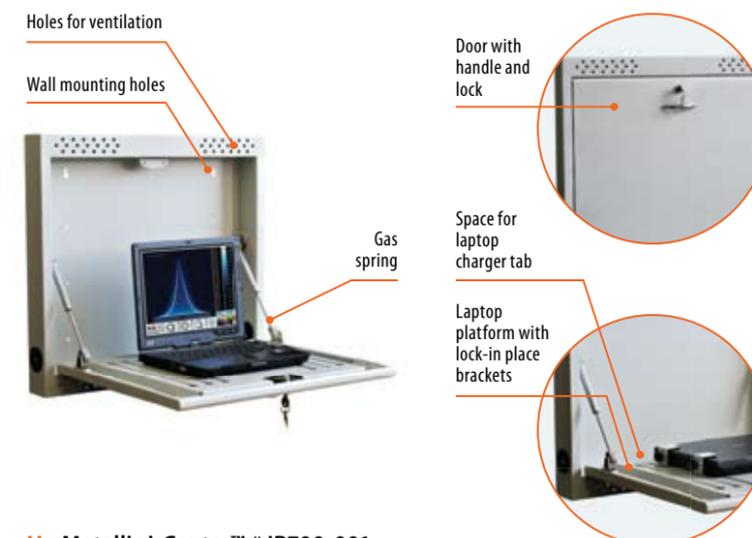

H. Metallic i-Center™ # IR700-001
(23.75"W x 3"D x 22"H) for laptop

Combo Arms AFC7808 and AFC7810 Series

The **AFC7808** and **AFC7810 Series** offer height-adjustable, low-profile, user-friendly solutions for access to electronic records where space is at a premium. The wall mount accommodates most operators, in sit-to-stand positions. When not in use, it folds up neatly to the wall, tucked away and unobtrusive.

The flexible **AFC7808** and **AFC7810 Series** are designed with the ergonomic intelligence, strength, durability, and thorough disinfection properties like other AFC products, while offering an easy-to-operate tool for boosting productivity. They are pneumatically height-adjustable within a 12-inch range, and can be

locked in any position you chose. Full range of swivel motion at each joint comfortably accommodates different positions and applications, such as sharing information with patients and other professionals in proximity.

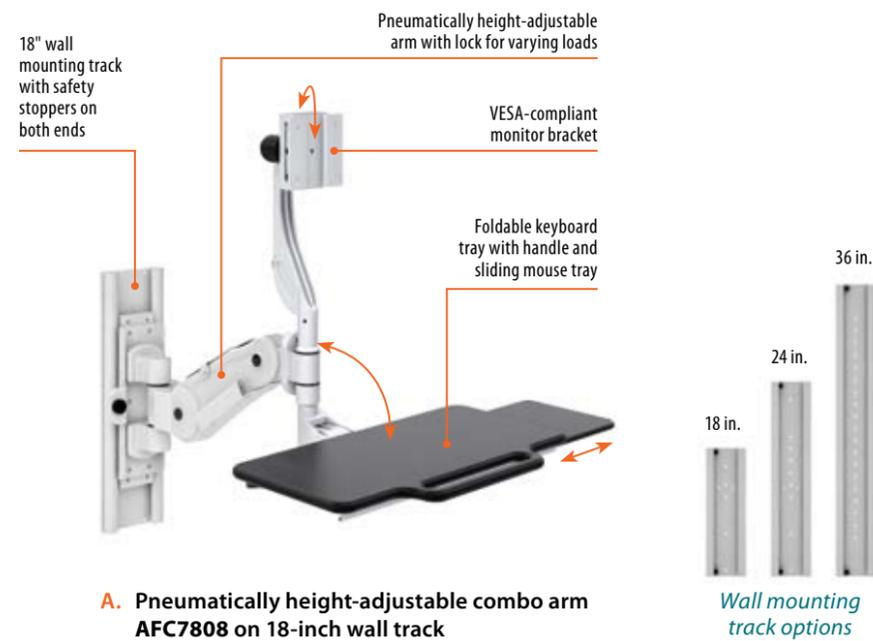
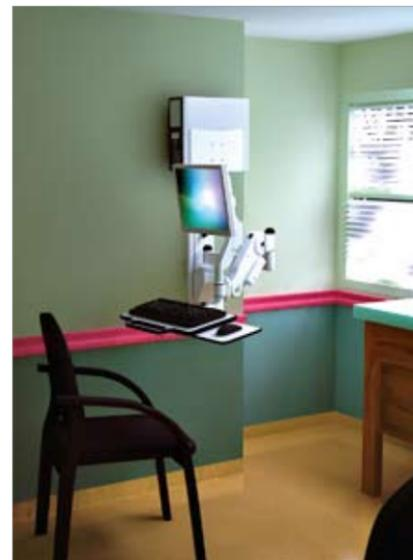

A. Pneumatically height-adjustable combo arm AFC7808 on 18-inch wall track

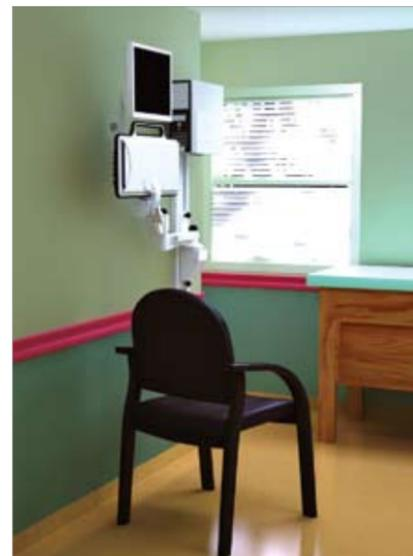

When not in use, it folds up tight to the wall, tucked away and unobtrusive

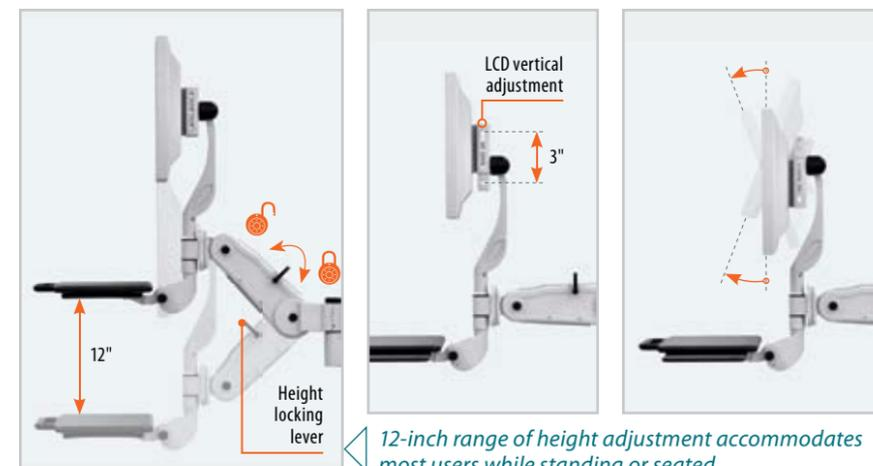

Features & Benefits

- Light-weight aluminum construction for easy operation
- Anti-microbial coatings for thorough disinfection for safe use throughout medical facilities
- Sit-to-stand work positions
- Height locking mechanism at any position for safety, stability, and varying loads
- Full range of swivel motion at each joint
- Keyboard folds for low profile and has a safety lock
- 12-inch range of height adjustment for accommodation of most users
- 34" fully extended from the wall
- 10" when retracted and folded to the wall
- VESA 75/100 compliant monitor bracket with horizontal and vertical tilt and 3-inch range of height adjustment
- Mouse holder is included
- Integrated wire management
- Standard color: Gray (call for custom colors)
- Can be mounted directly on a wall or desk
- Option of supplemental 12" or 20" extension arm
- Arm vertically adjusts on 18", 24" or 36" wall track (wall track is optional)

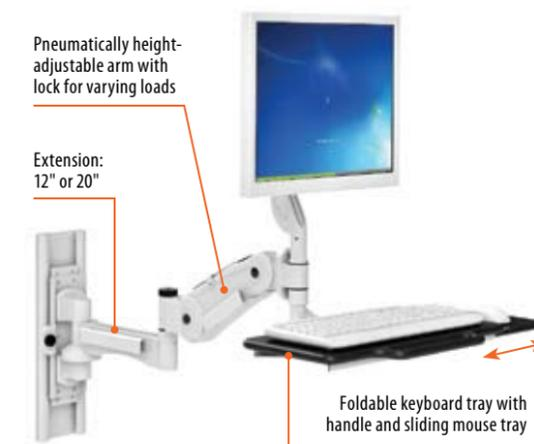

B. Combo arm AFC7808 with 12-inch extension on 18-inch wall track

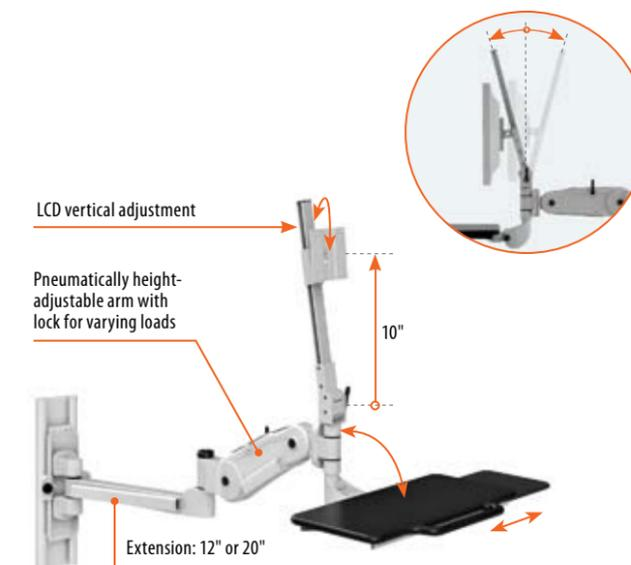

C. Combo arm AFC7810 with 20-inch extension on 18-inch wall track



Keyboard tray with integrated handle easily folds up, saving space when not in use

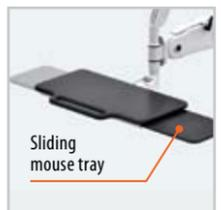

Mouse tray slides to accommodate left- and right-handed users



With the keyboard folded up, total system depth is as little as about 8"



Clean, concealed and neat routing of cables through the cable management system

Mounting Options



Vertical mounting



Horizontal mounting



Desktop mounting



D. Combo arm AFC7808 on 36-inch wall track with CPU holder # CPU-101



E. Combo arm AFC7810 with 20-inch extension on 24-inch wall track with CPU holder # CPU-101

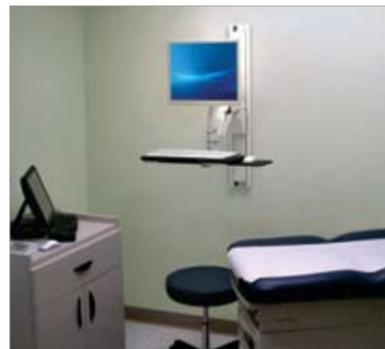

The flexible combo arm AFC7808 allows the user to work at seated or standing position and provides full range of swivel motion at each joint



Wall Mount # AFC7810_20 with CPU holder # CPU-919 and shelf on articulating arm

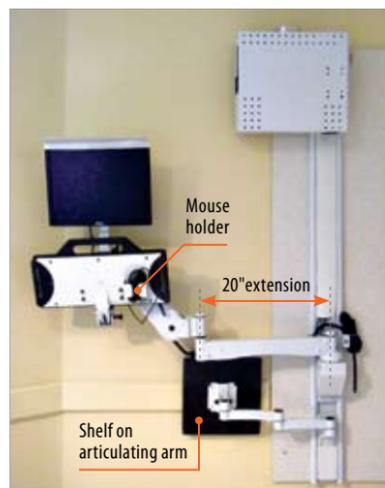

Wall Mounts

AFC Wall Mounts are perfect for high-traffic areas because of their compact design. This space-saving solution is also ideal for areas where multiple operators use a single computer workstation.

Our monitor and keyboard wall mounts enable you to adjust both the keyboard and monitor height from a seated to standing position, as well as from left to right.

Features and Benefits

- All components are individually adjustable in increments of 2"
- Safety stoppers at both ends
- Spring-loaded locking mechanism for simple and easy height adjustment
- VESA-compliant monitor holder that can be adjusted from portrait to landscape view and tilted to avoid glare
- Foldable and retractable keyboard arm and mouse tray
- Adjustable CPU holder (3 1/2" - 8 1/2"W, 13" - 25"H)
- Multiple colors available (for standard colors, see page 103)
- Additional accessories available (see page 92)

Optional

- Horizontal or vertical positioning
- Double monitor holder on single track (see "Optional Monitor Arms for Wall Mount" on the next page)
- Horizontal track for multiple monitors
- UPS Holder
- Mouse Holder

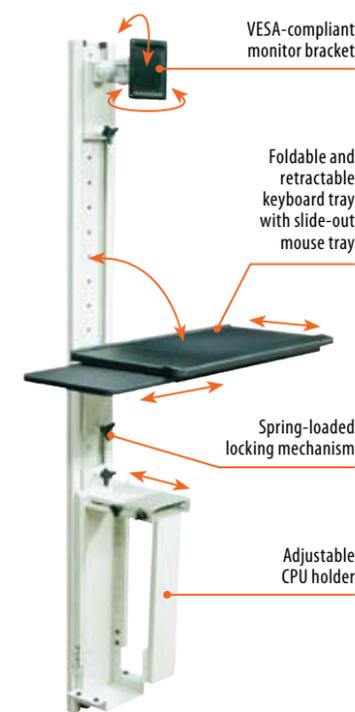

Wall Mount # WM-RKMC

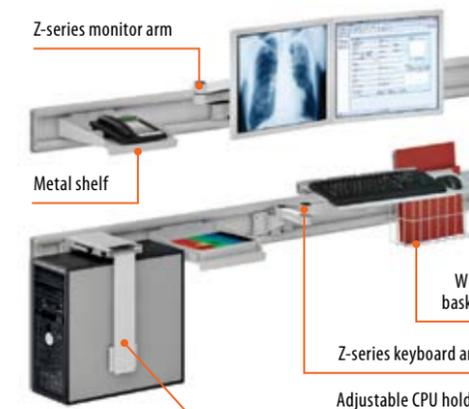

Wall mount for multiple monitors on horizontal track

More Mounting Solutions with AFC7808 Series



Monitor arm



Keyboard arm



Laptop arm

Optional Monitor Arms for Wall Mounts

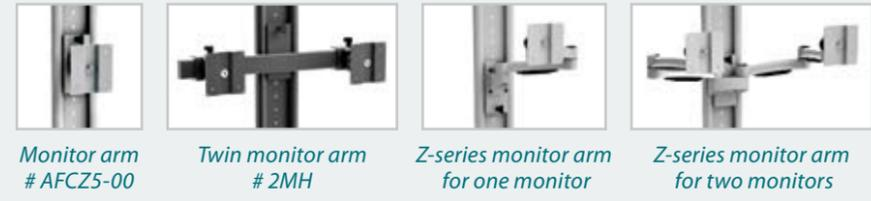

Interactive Builder
Configure your own
Wall Mount at
www.afciindustries.com/wallmount

84 in.
56 in.
36 in.
24 in.

4", 6", 8"
6"
8" 6"

AFCZ5-00
AFCZ560
AFCZ568

Wall tracks with safety stoppers on both ends

A. Wall Mount with electronic height adjustment # WM202-01

- 19" of electronic height adjustment of the unit
- Components are individually adjustable
- Monitor tilts up and down
- Metal keyboard tray with retractable mouse tray
- Adjustable CPU holder # CPU101



B. Wall Mount with pneumatic height adjustment # WM-RKMC-P-04

- 12" of pneumatic adjustment of the unit
- Monitor tilts up and down
- Retractable and foldable keyboard tray with slide-out mouse tray
- Adjustable CPU holder # CPU 13-25

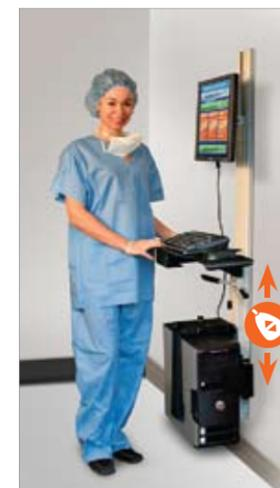

D. Wall Mount # WM36-NH-1F-1KS-C101



E. Wall Mount # WM56-2FZ-KB82R-U-C13_25



G. Wall Mount # WM84-1F-2KBZ-C101-PSH

Wall Mount Pole



H. Wall Mount Pole # WMPL_52_F_KB_C_001



F. Wall Mount # WM56-1F-KBZ-Sh-C101

More solutions to complete your Wall Mount (see page 99 for more accessories)

Metal keyboard tray

Foldable shelf on Z-series arm

Z-series keyboard arm with tray

Z-series arm for laptop

CPU-101 # CPU 13-25
CPU-9CS909 # CPU-919

Video Wall

The **Video Wall** consists of one or more tracks for sliding the monitor arms from left to right, where every single arm allows tilting up-down and left-right, as well as micro-adjustments to eliminate gaps between monitors.

Z-arms give each monitor an ample range of motion, allowing you to position them in several different viewing arrangements. AFC also offers the **Monitor-Wall Stand** that is designed and manufac-

tured to support your specific monitor configuration and fit in your unique space. The stand design is flexible, modular, mobile and can be configured as an in-line, concave, or convex mounting solution.



Three-row Video Wall for 15 monitors

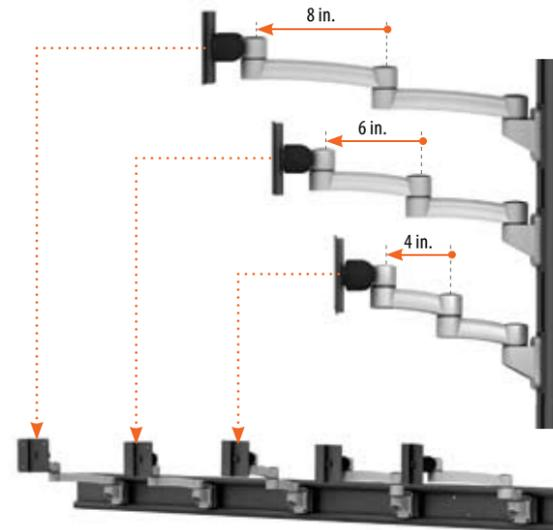

Features and Benefits

- Aluminum track with mounting holes and safety stopper at both ends allows monitor holders to slide
- Horizontal or vertical mounting of tracks
- Z-arm monitor holders with extension, tilt, and pan motion; arms have varying length to provide parabolic shape for optimum viewing
- VESA-compliant monitor holder that can be adjusted from portrait to landscape views and tilted to avoid glare
- Combination setup allows horizontal and vertical adjustment of the monitors
- Monitor travels from 4" to 20" from the wall
- Multiple colors available (for standard colors, see page 103)

Optional

- Monitor holders # AFCZ5-00, # AFCZ540, # AFCZ560 (tilt and pan only)
- Non VESA-compliant monitor holders available for larger flat screens



The outer monitor arms are longer than at the center, which lets you create a comfortable viewing arc. When laid out straight, the monitors can get as close as 4" to the wall.

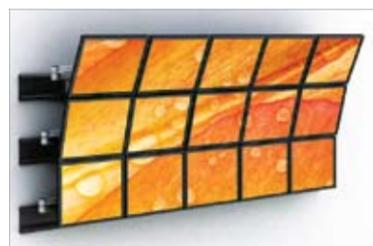

The Video Wall's freedom of motion allows you to combine monitors of different shapes and sizes, in any arrangement, without gaps.



The primary frame of the **Monitor-Wall Stand** is built from steel with a powder-coated finish for durability and can support any size flat screens.

The **Monitor-Wall Stand** features a horizontal track with an array of monitor mounts that allow the user to align and position the monitor in the most optimum viewing position. Built-in wire management conduits allow the routing of cables from the screen all the way to the floor/ceiling in a discreet manner keeping in mind the aesthetics of the room it is in.

The unit features a variety of accessories like power strips, CPU holders, and adapter holders that can be added to the **Monitor-Wall Stand** to create a free-standing monitor wall. Rather than have an empty space below the screens, we can provide you with a panel (fabric, metal, or laminate) to match your décor which can also double up as a bulletin board, modesty panel (to hide some electronics and cables), or just to make it more appealing.



Each track is adjustable in increments of one inch.

Each monitor can slide from left to right



Optional panel with your choice of finish — laminate, fabric, or metal — to match your décor



The stand design is flexible, modular, and can be configured as in-line, concave, or convex configurations

Floor Post™

The **Floor Post Series™** creates a more effective, comfortable, and productive work environment. Based on your specifications, you can have unlimited configurations for any task.

Its space saving design also allows multi-side (front/back/side) user capability.

The **Floor Post Series™** can be mounted to various floor surfaces.

Monitor, keyboard arms, CPU holders, shelves and other accessories can be made height adjustable on a secure track making the **Floor Post Series™** suitable for multi-users.

Features and Benefits

- All components are individually adjustable
- Spring-loaded locking mechanism for simple and easy height adjustment (depending on item)
- Built-in wire management
- Monitor holders of your choice: AFC10E/F/G, AFCZ5-00, AFC7808M_01 (see page 97)
- CPU holders of your choice: CPU-101, CPU13-25, CPU-08, or CPU-09 (see page 99)
- Multiple colors available (for standard colors, see page 103)
- Additional accessories available (see page 92)

Specifications

- Base footprint: 16"W x 16"D
- Overall height from the floor: 60"

Optional

- Double-monitor holder
- Foldable and retractable keyboard arm with sliding mouse tray
- Additional shelves
- Camera holder

Available Colors

- Putty ● Black
- Gray ○ White

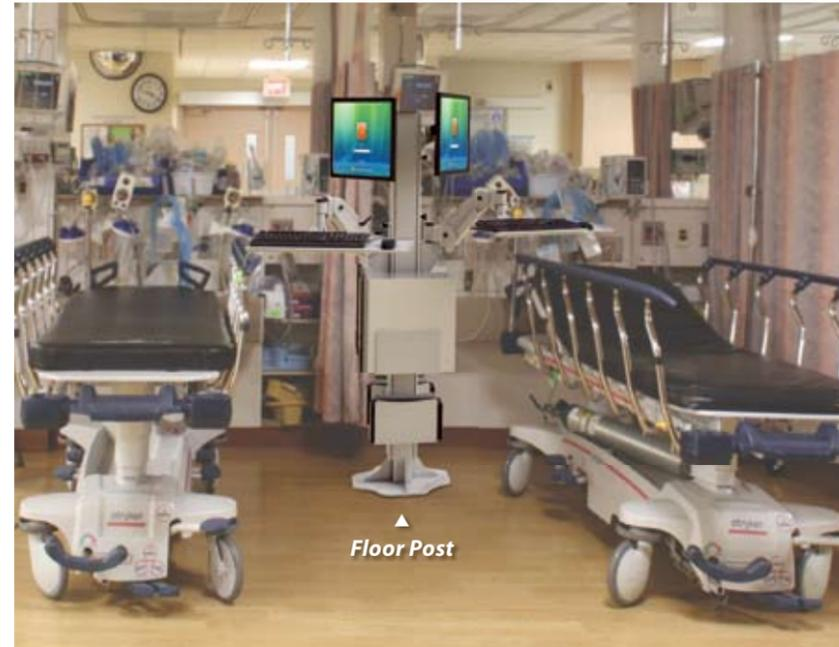

The Floor Post's space saving design allows multi-side (front/back/side) user capability

A. Floor Post™

- Two 62"H tracks
- Two Monitor Arms # AFCZ5-00
- Two pneumatically height-adjustable Keyboard Arms with keyboard trays and sliding mouse trays # AFC7808K_01
- Four CPU Holders # CPU-101
- Floor-mount base

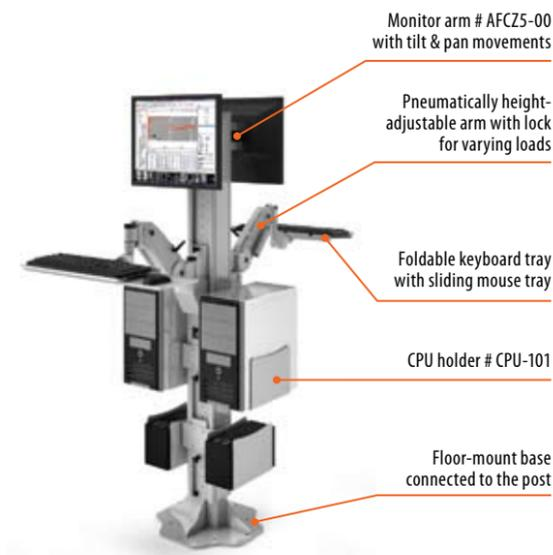

B. Floor Post™

- 62"H track
- Height-adjustable camera holder
- Monitor Arms # AFCZ5-00
- 24"W x 16"D work surface
- 18"W x 10"D retractable keyboard tray
- CPU holder # CPU-101
- Wire basket # WB-100
- Floor-mount base



C. Floor Post™

- 50"H track
- Monitor Arm # AFCZ5-00
- 30"W x 18"D work surface
- 18"W x 10"D retractable keyboard tray
- CPU holder # CPU-101
- Floor-mount base



D. Floor Post™

- 50"H track
- Monitor Arm # AFCZ5-00
- Pneumatically height-adjustable Keyboard Arm with keyboard tray and sliding mouse tray # AFC7808K_01
- CPU holder # CPU-101
- Wire basket # WB-100
- Floor-mount base



E. Floor Post™

- Two 50"H tracks
- Pneumatically height-adjustable Monitor Arm # AFC7808M_01
- Monitor Arm # AFCZ5-00
- Metal shelf
- CPU holder # CPU-101
- Wire basket # WB-100
- Floor-mount base

F. Floor Post™

- 60"H track
- Monitor Arm # AFCZ5-00
- Z-series Keyboard Arm with keyboard tray and sliding mouse tray # AFCZ588-01
- Emergency stop switch enclosure
- 7.5"W x 7.5"D utility shelf
- Floor-mount base

G. Floor Post™

- 60"H track
- Monitor Arm # AFCZ5-00
- Height-adjustable equipment enclosure with emergency stop switch
- Custom Keyboard tray
- Floor-mount base



Adjustable Detector/Cassette Stands for flexibility and accuracy with minimal effort

New at AFC are products designed for image stitching applications in the assessment of Scoliosis, Long Leg, and other disorders. Whether diagnosing in a computed radiography or digital radiography environment, our new flexible scoliosis products offer ergonomic and flexible solutions that adapt to your needs.

Spine Smart™ Digital Radiography Detector Holder

FOR SCOLIOSIS AND IMAGE STITCHING APPLICATIONS

The **Spine Smart™** height-adjustable mobile detector stand is used in applications with a digital radiography (DR) detector, and can be modified to specifications. It increases accuracy and decreases time per procedure, based on AFC engineering and design. Color-coded adjustable markers ensure optimal positioning of the detector. A clear acrylic panel and securing straps maximize patient positioning during the procedure.



Features and Benefits

- Constructed using high-grade steel and aluminum allowing the unit to be cleaned and disinfected using standard medical cleaning agents
- Electronic height adjustment accommodates patients of various sizes
- Independent detector and grid holders allows for insertion and removal of detector without removing the grid
- Detector and grid can be rotated 90° in either portrait or landscape
- Color-coded adjustable markers allow easy detector positioning for image stitching
- Straps and a clear acrylic panel improve the accuracy of patient positioning
- Handle and small footprint with large 4" wheels provide for easy movement from room to room with detector and grid in place
- Two front locking casters secure placement of the stand

Specifications

- Footprint: 30"W x 22"D
- Detector and grid can move from 6" to 31" above the floor accommodating patients of various sizes

Optional

- Color-coded adjustable markers on either left or right side

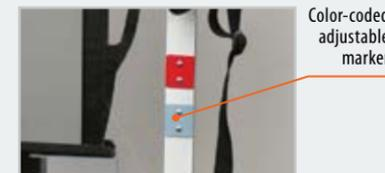
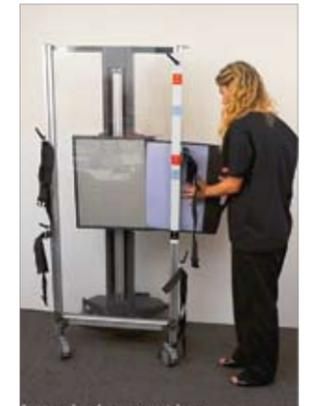

Color-coded adjustable marker

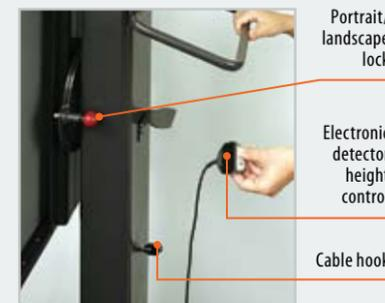

Portrait/landscape lock

Electronic detector height control

Cable hook



Position the detector in either portrait or landscape view

MACH-ONE™ X-ray Cassette Holder

FOR SCOLIOSIS AND IMAGE STITCHING APPLICATIONS

The **MACH-ONE™** is a height-adjustable mobile X-ray cassette stand used in computed radiography (CR) applications. It is available with either electronic or pneumatic height adjustment and accommodates cassettes of many different sizes and shapes.

The **MACH-ONE™** is also available as a wall-mounted product.

Features and Benefits

- Constructed using high-grade steel and aluminum, for cleaning and disinfection with standard medical cleaning agents
- Pneumatic or electric height adjustment
- Adjustable cassette holder accommodates all standard cassette sizes such as 8"x10", 10"x12", 14"x17", 14"x34", 14"x50" and more
- Independent cassette and grid holders
- Cassette and grid can be rotated 90° in either portrait or landscape
- Handle and small footprint with large 4" wheels provide for easy movement from room to room with cassettes and grid in place
- Two front locking casters secure placement of the stand

Specifications

- Cassette and grid can move from 6" to 31" above the floor, accommodating patients of various sizes

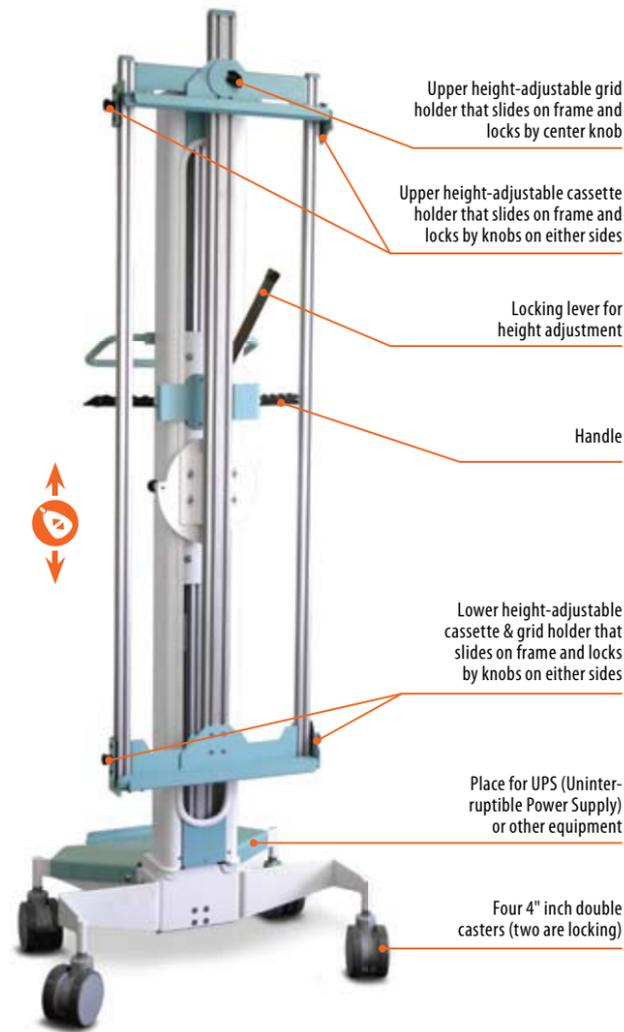

MACH-ONE™ with pneumatic height adjustment



Cassette and grid can be rotated 90° in either portrait or landscape



14" x 50" cassette



14" x 17" cassette



10" x 12" cassette



MACH-ONE™ with electronic height adjustment

Spring loaded knob that holds cassette holder either in vertical or in horizontal position

Main cable

Control switch for vertical adjustment

Two front locking casters secure placement of the stand

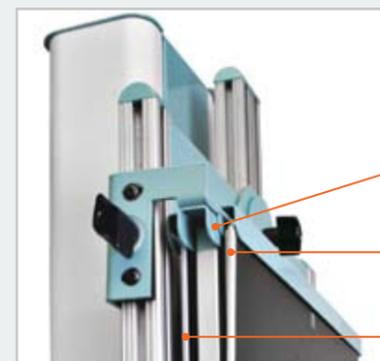

Adjustable cassette holder

Anti-scatter grid

Back scatter panel

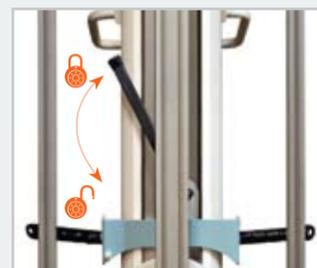

The cassette holder height is conveniently adjustable with the locking release lever



Spring loaded knob that holds cassette holder either in vertical or in horizontal position

The wall-mounted **MACH-ONE™** is a good example of AFC's flexibility to adapt its products to meet customer needs. It was designed on request of a facility with overriding space constraints.

The wall-mounted **MACH-ONE™** provides additional benefits, such as protection against equipment theft and easy location of this valuable diagnostic tool on demand.



Wall-mounted MACH-ONE™



Secure your healthcare facility with AFC's flexible Control Consoles

We live in a world of rising security needs. Medical facilities are not immune. Whether protecting lives, sensitive patient information, or property, security has become an essential operational concern.

Our line of adjustable security consoles and video walls enable many areas of a facility to be simultaneously monitored by a single or multiple operators and can be easily relocated as needed.

We produce a wide array of mounting solutions that meet the extensive needs for video and CCTV surveillance of outer and inner areas, whether on single or multiple monitors. AFC's modular racking systems facilitate efficient storage of valuable electronic and audio-visual equipment.

Control Pod Consoles

Large medical centers. Hospitals. Imaging centers... critical facilities to secure and so many areas to monitor — multiple entrances and exits; operating rooms and other restricted zones; patients, employees, and visitors; sensitive patient and institutional information, valuable equipment, and more.

Features and Benefits

- Monitor platform accommodates monitors of different shapes and sizes, in any arrangement, without gaps
- First and last columns of monitor arms have longer reach to provide optimal parabolic viewing shape
- Built-in extra-quiet fans for CPU ventilation
- Cold-rolled 11-gauge steel frame with epoxy-powder-coated finish
- Particle-board-core top with your choice of high-pressure laminate finish, edged with bumper molding or T-molding
- Multiple colors available (see page 103)
- Glides or 4" casters
- Additional accessories available (see page 92)

Optional

- Electronic height adjustment of work surface and monitor platform
- Retractable work surface to adjust the distance from the monitors
- Lockable 3-drawer pedestals
- Mesh doors for front and rear CPU access
- Pop-up data ports and built-in USB hub embedded in the work surface
- Footrest

Our **Control Pod Consoles** are perfect for applications that require viewing multiple monitors simultaneously. Cover all critical areas of your facility at one integrated console or at several consoles, using monitors of different sizes and configurations, according to your needs.

Control Pod Consoles are offered with optional electronic height adjustment of the work surface for multiple users in a 24 x 7 environment, and for sit-to-stand working

positions that help maintain alertness and concentration. Independent electronic monitor adjustment is also available for both monitor height and focal length to ease eye strain and optimize performance of security personnel.

Horizontal adjustment of monitors along tracks and vertical micro-adjustment eliminates gaps between monitors. Extensions on the outer monitor arms allow for a more comfortable viewing arc.



Three-drawer pedestal

A. Control Pod Console

- Monitor platform with manually height-adjustable monitor rail system for different size monitors¹
- Two three-drawer pedestals
- Glides

¹ Monitor holder bracket might vary based on size/weight/model

Monitor platform accommodates monitors of different shapes and sizes, in any arrangement, without gaps



CPU enclosure with mesh door

B. Control Pod Console

- Monitor platform with manually height-adjustable monitor rail system for different size monitors
- Grommet-mount Z-series monitor arm
- Two pedestals
- Glides



Designed with ergonomic intelligence for a wide range of users and needs, AFC's consoles help professionals work more comfortably and effectively.

The **B-Line Consoles™** are designed to allow you to line them side by side in front of a central set of screens. The consoles have ventilated cabinet enclosures and available in two configurations: one is for recessed monitors, another — with a rack mount option to house your equipment.

We can customize the consoles to perfectly fit your space, equipment, and other specifications.

Open Control Consoles

Open Control Consoles come in two configurations: the monitor height can either be adjusted independently of the work surface (images A), or can move together with the surface (image B).

The consoles come in multiple surface shapes (see page 14) and colors, and feature an optional retractable work surface for adjusting the distance to the monitors.



Pop-Up Units include Ethernet network and parallel ports as well as standard AC power outlets

A. Open Control Console with electronic height adjustment:

- Independent electronic height adjustment of work surface and monitor platform
- Retractable work surface
- Pop-up data and power ports
- 4" casters

C. B-Line Console™ for recessed LCD monitors

- Two Z-series arms # AFCZ568
- Two cabinet enclosures with mesh doors
- 2" twin casters (the front two are locking)



Z-series monitor arm provides an adjustable viewing depth for LCD monitor



Storage with mesh doors for ventilation



Electronic Adjustment:

- SURFACE HEIGHT
- MONITOR HEIGHT (optional)

D. B-Line Console™ with two rack mounts

- Grommet-mount Z-arm for two monitors # AFCZ588-02
- Two 3U rack mounts
- Two 2-door cabinet enclosures
- Removable back panels with mesh for ventilation
- Glides



Grommet-mount Z-arm for two monitors



Removable back panels ease access for wire management and servicing



B. Open Control Console 60"W x 36"D:

- Electronic height adjustment of work surface
- Manually height-adjustable monitor rail system for different size monitors¹
- Bottom shelf
- 4" casters

¹ Monitor holder bracket might vary based on size/weight/model

Our non-electric **Open Control Console** has fixed work surface height and a manually height-adjustable rail system with two big monitor holders (image C).



C. Open Control Console with a fixed height:

- Manually height-adjustable monitor rail system with two monitor holders # AFC3255-01
- Two split bottom shelves
- Two wire managers # WMF100
- 4" casters





Accessories help to optimize ergonomics in your workspace

AFC Industries has an entire division devoted exclusively to designing accessories for every conceivable requirement.

From ergonomically correct and functionally optimal monitor mounts to keyboard trays with retractable features; from ambient and task lighting solutions for different needs and applications to cable management; from attachments for holding a telephone and/or dictation equipment to a beverage cup, and much more.

Visit www.afcindustries.com/accessories to learn about our wide array of accessories for a multitude of needs.

Partitions

Complete your work area using AFC **Partitions**. These partitions absorb sound and provide privacy. They also prevent interference from monitors or other light sources. They can be manufactured with a tinted or clear Plexiglas panel across the top so operators can see outside of their "cubicle."

AFC offers both free-standing partitions and partitions affixed to the floor or cart. Our partitions can be configured to suit your application.



Features and Benefits

- One-inch sound-absorbing fiber with reflector on one side
- Cold-rolled 11-gauge steel frame with epoxy-powder-coated finish
- Prevents light interference
- Can be used as a tack board
- Multiple colors available (for frame colors, see page 103)
- ¼" thick free-standing base

Specifications

- Width: 36", 48", 60", 72"
- Height from the floor: 60", 72"

Optional

- ⅛" tinted or clear Plexiglas top
- Fiber top with removable lower metal panel and built-in continuous cable management
- Free-standing, mobile (2-inch twin casters), or affixed to the floor/cart

Fabric Standard Colors

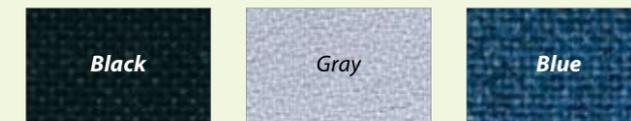

A. Partition
60"W x 60"H
with sound-absorbing fiber



B. Partition
60"W x 72"H
with tinted Plexiglas top



C. Partition
72"W x 72"H



D. Partition
72"W x 72"H
with tinted Plexiglas top





E. Metal Partition affixed to the workstation



F. Partitions affixed to the floor

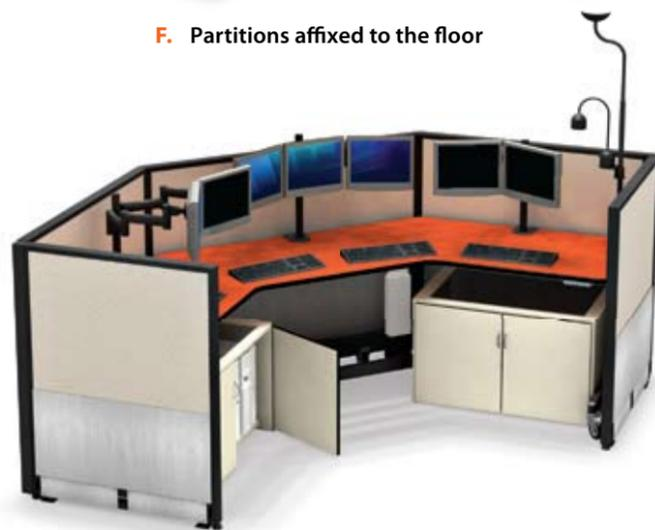

G. Partitions affixed to the floor:

- Light and sound barrier fiber top
- Removable lower metal panel allows back CPU access
- Built-in continuous cable management



H. MobiCube™ 64"W x 48"D x 60"H

MobiCube™ panels can roll anywhere or be mounted on AFC's workstations to instantly create a reading-room environment. These partitions use special hinges that allow you to position them at any angle from 0-90°. They can lock into place using the two lockable casters.

The MobiCube™ can either create a cubicle or act as a partition along the length of the room itself, without going through the complexities of installation or building codes, as all our products come fully assembled.



MobiCube™ Configurations

LCD Monitor Arms/ Holders

AFC Industries Inc. provides a variety of solutions for mounting LCD monitors. We offer four categories: **Desktop series, Z-series, Wall Mount series, and Ceiling Mount series.**

Our Desktop series includes three types of VESA-compliant LCD monitor arms: grommet-mounted, base-mounted and clamp-mounted.

Combining style with functionality, the Z-series with articulating monitor arms allows you to position your monitor at any viewing level, angle, and depth from the viewer, providing maximum flexibility. The Z-series comes with a clamp that can also be wall-mounted.



Base-mounted electronically height-adjustable LCD monitor & Keyboard Arm # ERGODT-01

Want to go from sit to stand at the touch of a button? Not a problem!

Install our ERGODT-01 on your existing table/work surface and within minutes you have a complete electronically height-adjustable work space!

Features

- Electronic height adjustment of 19"
- Fully articulating and retractable keyboard arm provides maximum freedom of motion
- VESA 75/100 compliant monitor mount with up/down tilt, right/left swivel and also rotation from portrait to landscape
- Independent vertical adjustable mounts for both the monitor and keyboard to set the desired spacing between the keyboard and monitor at 2-inch increments
- Rear shelf provides space to place CPU if required or just storage space for any of your other equipment



Electronic Adjustment:
▪ MONITOR/KEYBOARD HEIGHT



Desktop Series

Base-mount AFC03	Base-mount AFC03A	Base-mount PEDPOLARM	Grommet-mount AFC01	Grommet-mount AFCRAIL01 (w/ AFC10F)	Grommet-mount AFCRAIL01 (w/ AFC22)
Grommet-mount AFC7808_12_DM-01		Clamp-mount AFC02	Clamp-mount AFC11	Clamp-mount AFCFLEXOARM	
Clamp-mount AFCPOLE	Clamp-mount AFCPOLE2MV-1	Clamp-mount AFCPOLE2MH-1	Clamp-mount AFC-KM-COMBO	Grommet-mount AFCPOLE2-OP-0	Clamp-mount AFCPOLE2-OP-1

Z-Series

AFCZ500-01	AFCZ500-02V	AFCZ500-02	AFCZ500-03	AFCZ500-04
AFCRAILZ03-3CLAMP			AFCZ500-05	AFCZ500-06

Wall Mount Series

AFC10AC	AFC10E	AFC10F	AFC10G	AFCZ5-00	AFCZ6-00	AFCZ660
AFC05	AFC11B	AFC12	AFC2530	AFC3255-01		
AFCZ5-00	AFCZ560	AFCZ568	AFCZ500-05-WMH			
W2M-BAR	W3M-BAR	W4M-BAR				
WM18_AFC7808M_01	WM18_AFC7808_01	WM18_AFC7808-12_01	AFC109-KM-01			
AFC135	WM110_4PLE18_4F		WM-AA-3250-UP-LB22			

AFC also offers a variety of **electronically-adjustable monitor platforms** that allow you to change the height of the monitors and move them forward and backward at the touch of a button, for superior viewing results. These platforms accommodate up to six LCD monitors (depending on cart size and monitor weight) and can be mounted on all AFC workstations (see the sidebar on page 15 for details).

Ceiling Mount Series

The **Ceiling Mount** is a simple but sturdy LCD monitor arm that allows users to adjust the monitor at their required height and viewing angle. It also allows rotation and tilt positioning of the monitor. Cables can be wired through the tubing for connection to the monitor.

Ceiling Mounts come with a standard VESA 75/100 plate. Non VESA-compliant monitor holders are also available for large-scale LCD monitors.

A. Ceiling Mount # CM-Z

B. LCD Ceiling Suspension # CM-LCD1

C. LCD Ceiling Suspension # CM-LCD4

D. LCD Ceiling Suspension # CM-LCD2

E. Ceiling Mount # AFC107

F. Custom Ceiling Mount for 2 large LCD monitors with CPU compartment

G. Ceiling Mount for large LCD monitors # CMZ-1FZ-V1X3

Labels in diagram F: Ceiling mount on 48" pole, CPU holder with door on one side and mesh on the other, Wall mounting holes, Holders for large LCD monitors.

Laptop Arms

	Wall-mount WM18_AFC7808LP_01
	Wall-mount AFCZ566-01-LWM-01
	Desk-mount AFCZ566-01-LPM-01

CPU Holders

	Desk-mount CPU-01		Desk-mount CPU-03		Desk-mount CPU-05		Desk, pole, or wall-mount CPU 13-25		Desk-mount CPU-04		Desk-mount CPU-17
	Wall-mount CPU-06		Wall-mount CPU-08		Wall-mount CPU-903-18-5-18		Wall-mount CPU-16-AFC22		Wall-mount CPU-919		Wall-mount CPU-CS909
	Wall-mount CPU-09		Wall-mount CPU-801-WD		Wall-mount CPU-101		Base-mount CPU Cradle CPU-07		Base-mount CPU-99		Mobile CPU Cradle CPU-02

Phone Arms

	Phone Arm TA001
	Phone Arm TA002
	Phone Arm TA004B
	Phone Arm TA003B

Keyboard, Mouse, and other Accessories

	Keyboard Arm & Tray WM18_AFC7808K_01		Keyboard Arm KA6000		Keyboard Arm KA3656		Keyboard Arm KA7001		Keyboard Arm & Tray WM-TR-M		Keyboard Arm & Tray WM-TR-MZ
	Keyboard Tray TR1000		Keyboard Tray TR2000		Keyboard Tray TR3000		Keyboard Arm & Tray WM-TR-F-101		Keyboard Tray KB03		Writing Platform RWP-900
	Keyboard Storage Drawer KSD01		Pencil Drawer PD002		Wire Basket WB-100		Metal Film Box FB-100		Scanner Holder S01		Cup Holder MCH-100
	Antiseptic Wipe Holder AWH100		Biohazard Waste Holder BWH100		Mouse Holder M001		Palm Rest PAL1000		Rotary Mouse Platform RMP-1		Keyboard Wrist Rest WR006

Lighting

Task Light TAL100A	LED Task Light TAL400	Ambient Light AMBL002	AmbiTask Light Combo AMBL001
		<p>Note: AFC offers LED task lighting as well as lighting solutions using halogen or neon fluorescent bulbs. The AmbiTask Light Combo can be controlled with independent dimmer switches for total operator regulation of workstation lighting.</p>	
Task Light TAL200A	Under-Shelf Light TAL300F		
LED Backlight TAL500			

Glides & Casters

Adjustable Glide GLID-ADJ	5" Caster w/ brake CAS-5B
4" Caster CAS-4	4" Caster w/ brake CAS-4B
4" Caster w/ brake CAS-GPB	4" Caster w/ brake CAS-PB
3" Caster CAS-3	2" Twin Caster w/ brake CAS-2TB

Storage Accessories

Flipper Cabinet FC	Sliding Door Cabinet SDC	Wood Clipboard Holder			
One Door Cabinet with two adjustable shelves D0123	Two Door Cabinet with two adjustable shelves D0124	Rotating Resource RR			
Wood Film Box FB-100-1	Mobile Film Box FB-100	Metal Pedestal with 2 drawers P2BBF19MF	Metal Pedestal with 3 drawers P3BBF19MF	Wood Pedestal with 3 drawers P3BBB15MF	Pedestal with 3 drawers & lock P3BBF19MF
Mobile Storage with one drawer & two adjustable shelves D0103-2	Mobile Storage with three drawers & two adjustable shelves Dentalcart003	Mobile Storage with sliding counter top & three drawers D0102-1			
Mobile Storage with six drawers D0118	Mobile Storage with one adjustable shelf	Printer Cabinet & Pullout Shelf Unit			

Cable Management and Power Solutions

Cable Manager WM201	Cable Manager WM100	Corrugated Wire Hose WMF200A, B	Cable Wrap WM-400
Wire Clip WC100A	Grommet Outlets GROM-2, GROM-3	In-Desk USB Hub USB-04	Wire Managers WMF100 and WMF200
Portable AC Power System PS-TL-1	Surge-Suppressor Power Strip SS9000	Retractable Power Cord RPC-101	Wire Managers WMF100 and WMF200
Data & Power Ports DPA-01	Power Strips SS9003 (8 Plugs) and SS9004 (24 Plugs)	Cable Ties 10 CM03	

and more...

Back Support BS001	Ergonomic Foot Rest FR002
Side Extension EX	Air Fan FanR1-100
Printer Shelf/Rolling Shelf EXSHR META	Slatwall

From concept to installation

FREE on-site consultation

At AFC we want to get it right the first time, every time, to create a great custom environment for our Customers. That's why we will come to you to ensure we are maximizing your space and that everything is measured up just right. We will work with your team, at no charge to you, from the beginning to the end of your project.



FREE project support

Our team is here to assist you with your vision. We have the experience to help with your project and pride ourselves in going above and beyond to not just meet, but exceed your expectations.

FREE design service

We want to use our many years of experience creating spaces to take full advantage and help you go beyond your imagination. With some of the most mechanically advanced products, we will help you achieve your goals, all at no additional cost to you.

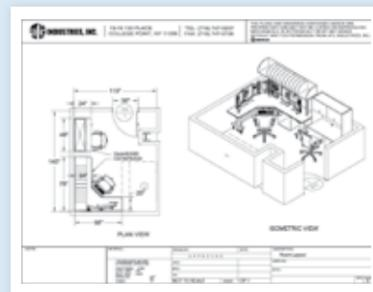

Customization

AFC can easily customize all products to adapt to your professional and individual requirements. Whether you need help choosing the right components to configure a product or are considering a complete room redesign, our staff is committed to offering you assistance every step of the way.



Outstanding customer support

Our experienced sales and engineering teams are here to walk you through the process from the smallest to largest jobs. Building rapport with our customers is a driving force throughout the relationship and is maintained during the entire project including follow-up.

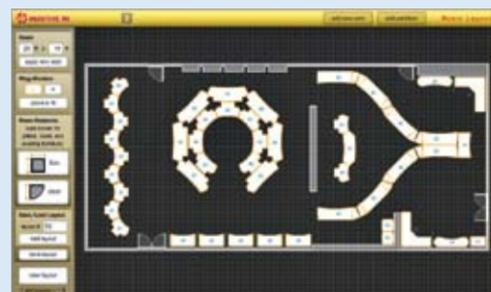

Use our **Room Layout Designer** to see how you can create an ergonomic environment with AFC's products

Standard Colors

Laminate



For any other color call us at 1.800.663.3412

Phenolic plastic



Molding



Frame

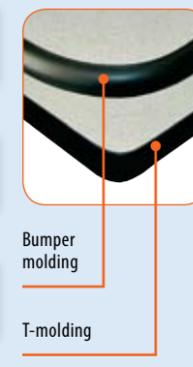

Anti-microbial paint



AFC now offers the added protection of anti-microbial powder-coat finishes on its products to provide protection against a broad spectrum of micro-organisms. When applied to mobile carts, wall mounts, and work stations the risk of spreading harmful bacteria and viruses between patients and health care workers is greatly reduced, according to doctors that use the anti-microbial powder coating in their hospitals and laboratories.

High-density polyethylene (HDPE) top now available with anti-microbial protection

A new kind of anti-microbial protection upgrade now available in many of AFC's polymer sheets, slabs and massive shapes. HDPE helps products stay cleaner between cleanings and inhibits the growth of product-damaging micro-organisms, including bacteria, algae and fungi on the surface. Microbe cell walls that come into contact with HDPE are destroyed on contact, without creating opportunities for adaptive or resistant strains to form. Because the anti-microbial agent is bonded at the atomic level throughout the sheet, it will not leach out of the product. This means the agent retains its effectiveness throughout the life of the product and does not harm the environment.

It is safe, non-toxic and non-hazardous to ship and handle. The product is EPA-registered and listed with the FDA as a modifier to medical devices.

Products made using AFC's polymers with HDPE are easy to clean, disinfect and keep hygienic using standard cleaning procedures. Constant use of cleaning solutions will not affect any polymer.



13-16 133rd Place • College Point • NY 11356

PRSR STD
US POSTAGE
PAID
AFC Industries, Inc.

Thanks

Complimentary Services

AFC Industries, Inc. is here to help you create the most comfortable and productive work environment possible. Our high-quality customer care includes complimentary 3-D product blueprints for all customized designs and detailed floor plans of your facility.

We welcome the opportunity to discuss your needs and find the best furniture solution for your business.

Custom Designs



Rigorous Quality Control



Delivery

We deliver our products fully assembled to ensure maximum quality and convenience for our customers.

Contact Us

Tel: 1.718.747.0237
Fax: 1.718.747.0726

Customer Support

1.800.663.3412

Visit Us

www.afcindustries.com