

TOP VIEW

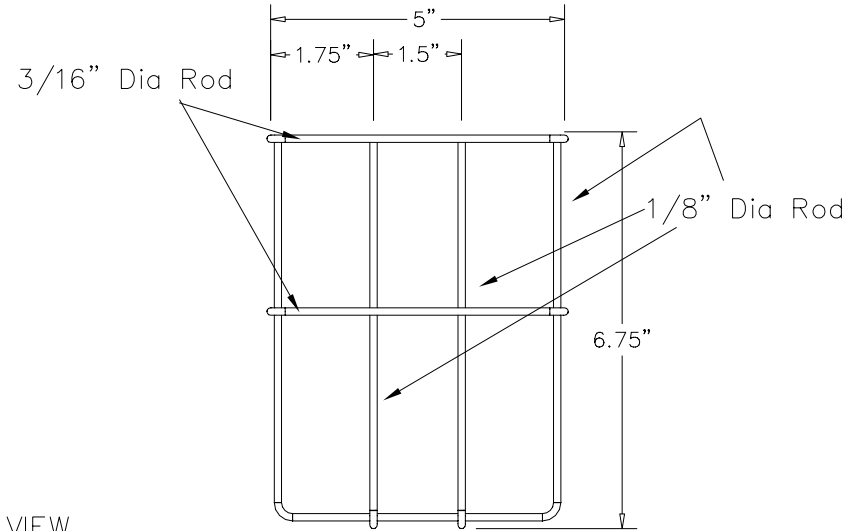

SIDE VIEW

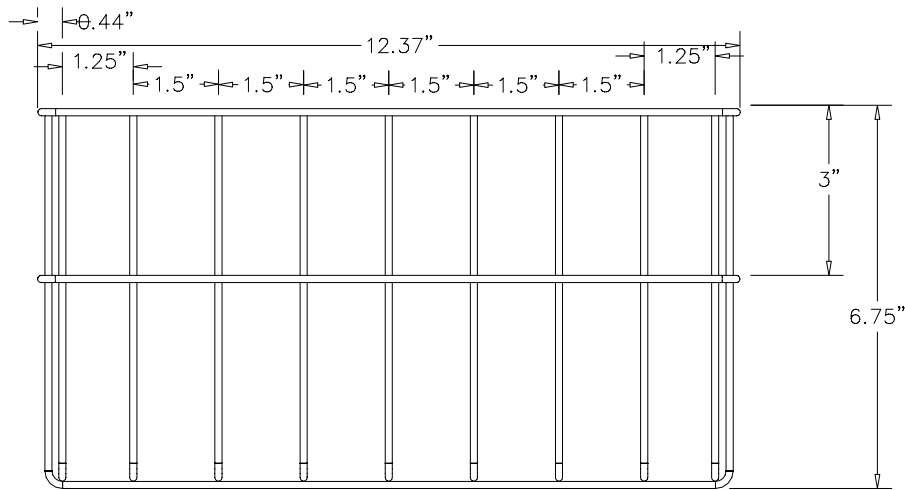

FRONT VIEW

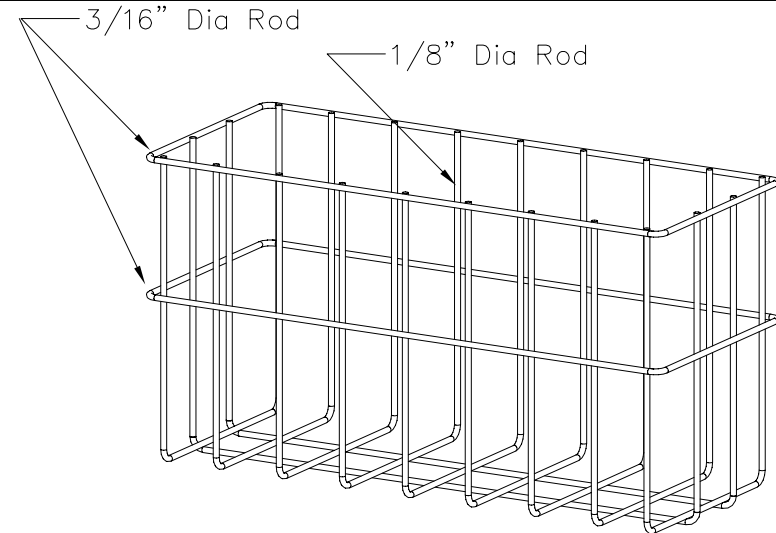

3D VIEW

NOTES :

MATERIAL :  
AS NOTED ABOVE

TOLERANCES UNLESS OTHERWISE SPECIFIED  
FRACTIONAL ±1/64  
2-PLC. DEC. ±.01  
3-PLC. DEC. ±.001  
ANGULAR ±.5°  
FINISH 32/

DRAWN BY : VGM

DATE: 03/10/05

A P P R O V E D

DESCRIPTION :  
File basket

ENG :

MFG :

QA :

SCALE : N.T.S.

SHEET : 1 OF 1

USED ON :

PATH : Accessories\Wire Basket

NUMBER : Wire Basket\_03

FOLDER :

REV: SIZE  
A