

**ISOMETRIC VIEW**

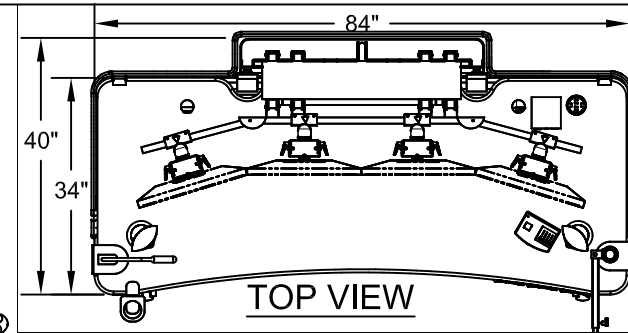

**TOP VIEW**

19" Stroke  
Electronically  
Height  
Adjustable

28"-47"  
Electronically  
Height  
Adjustable

- 1 ERGO ARMS (EFX) FOR FOUR MONITORS WITH (4)AFC2530
- 2 METAL PARTITION WITH ACOUSTIC ISOLATION
- 3 PERSONAL ENVIRONMENT CONTROL UNIT
- 4 LED LIGHT TAL400
- 5 CUP HOLDER
- 6 (2) 13"WX16" BOTTOM SHELVES
- 7 (2) CPU-07
- 8 (2)WMF200
- 9 (5)4" CASTERS (2) LOCKING
- 10 PHONE ARM
- 11 POP UP DATA & USB HUB
- 12 LED BACK LIGHT

NOTES :

MATERIAL :

DRAWN BY: PR

DATE: 12/16/09

DESCRIPTION:

WHITESTONE WORKSTATION

TOLERANCES UNLESS OTHERWISE SPECIFIED  
FRACTIONAL ±1/64  
2 PLC. DEC. ±.01  
3PLC. DEC. ±.001  
ANGULAR ±.5°  
FINISH 32

A P P R O V E D

ENG :

MFG :

QA :

SCALE :

SHEET : 1 OF 1

USED ON :

PATH : Maxflex\Whitestone

PDF NAME: WST8434PA B SE 0000 4F 2C 00 SB\_HWMJ-01

SIZE A