

1. Sony Image Core Screen (AFC2530)
2. Sony 24" Screen (AFC22)
3. Adaptor Bracket (4"Wx6"Hx2.5"D)
4. KB Tray on articulating arm

5. Handle
6. Shelf for Camera system
7. Shelf for Isolation transformer
8. Shelf for Printer

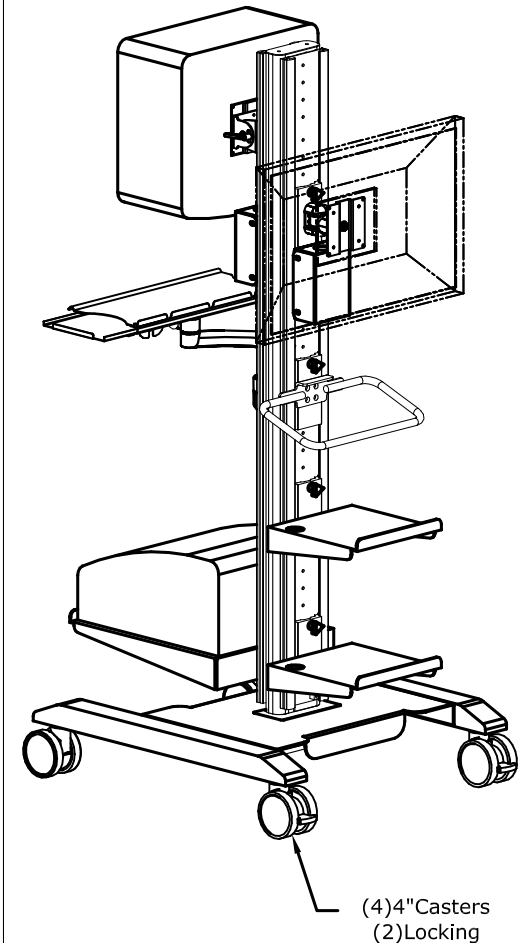
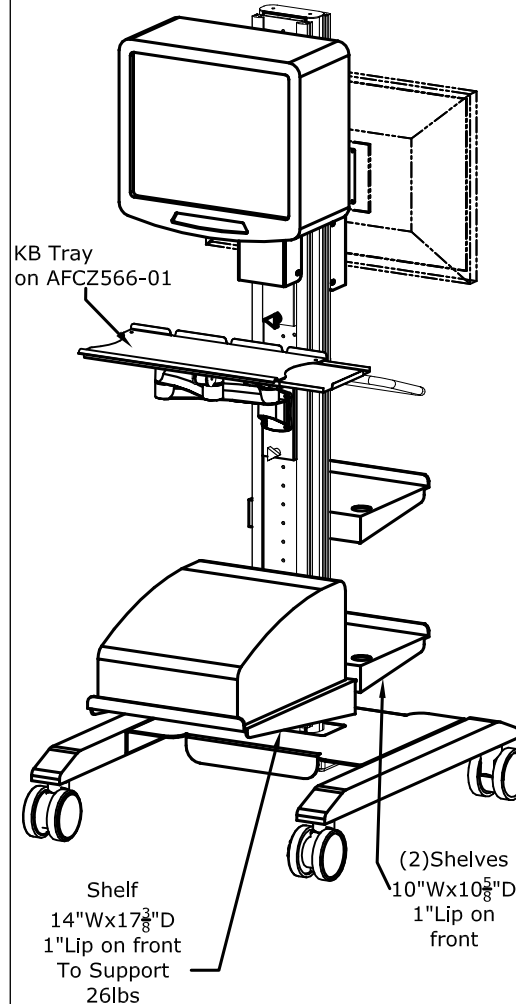
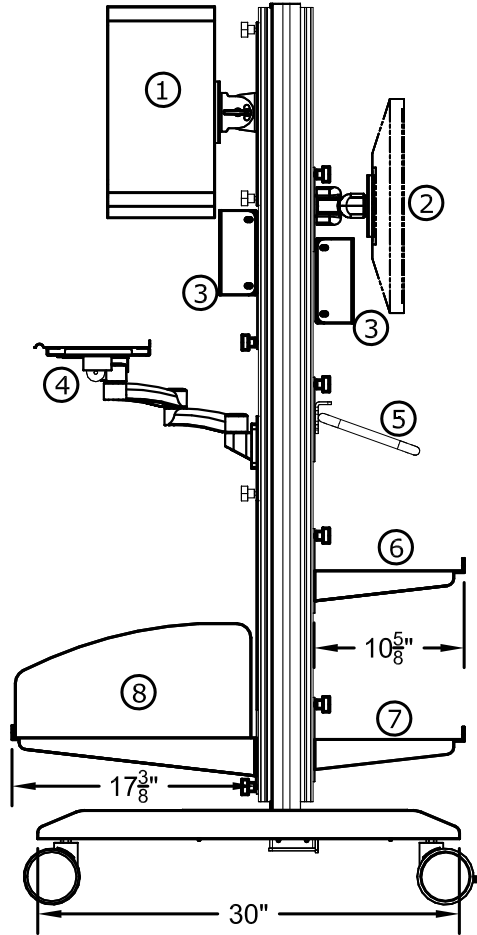
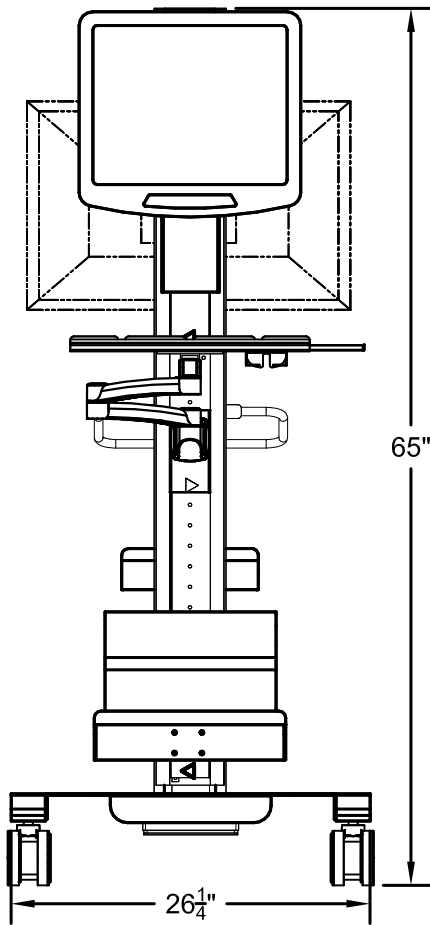

NOTES :

Concept Drawing only
final design may vary

MATERIAL :
AS NOTED ABOVE

TOLERANCES UNLESS OTHERWISE SPECIFIED
FRACTIONAL ±1/64
2 PLC. DEC. ±.01
3PLC. DEC. ±.001
ANGULAR ±.5°
FINISH $\sqrt{\text{Z}}$

DRAWN BY : PR

DATE: 05-19-2010

DESCRIPTION : Utility Cart

A P P R O V E D

ENG :

MFG :

QA :

SCALE : N.T.S.

USED ON : SONY

PATH : K:\Customers\SONY\IMAGECORE

PDF NAME: SNU_263065-03

FOLDER :

REV: SIZE
A